



ZFS On-Disk Specification

Draft

Sun Microsystems, Inc.
4150 Network Circle
Santa Clara, CA 95054
U.S.A

©2006 Sun Microsystems, Inc. 4150 Network Circle Santa Clara, CA 95054 U.S.A.

This product or document is protected by copyright and distributed under licenses restricting its use, copying, distribution, and decompilation. No part of this product or document may be reproduced in any form by any means without prior written authorization of Sun and its licensors, if any. Third-party software, including font technology, is copyrighted and licensed from Sun suppliers.

Parts of the product may be derived from Berkeley BSD systems, licensed from the University of California.

Sun, Sun Microsystems, the Sun logo, Java, JavaServer Pages, Solaris, and StorEdge are trademarks or registered trademarks of Sun Microsystems, Inc. in the U.S. and other countries.

U.S. Government Rights Commercial software. Government users are subject to the Sun Microsystems, Inc. standard license agreement and applicable provisions of the FAR and its supplements.

DOCUMENTATION IS PROVIDED AS IS AND ALL EXPRESS OR IMPLIED CONDITIONS, REPRESENTATIONS AND WARRANTIES, INCLUDING ANY IMPLIED WARRANTY OF MERCHANTABILITY, FITNESS FOR A PARTICULAR PURPOSE OR NON-INFRINGEMENT, ARE DISCLAIMED, EXCEPT TO THE EXTENT THAT SUCH DISCLAIMERS ARE HELD TO BE LEGALLY INVALID.

Unless otherwise licensed, use of this software is authorized pursuant to the terms of the license found at: http://developers.sun.com/berkeley_license.html

Ce produit ou document est protégé par un copyright et distribué avec des licences qui en restreignent l'utilisation, la copie, la distribution, et la décompilation. Aucune partie de ce produit ou document ne peut être reproduite sous aucune forme, par quelque moyen que ce soit, sans l'autorisation préalable et écrite de Sun et de ses bailleurs de licence, s'il y en a. Le logiciel détenu par des tiers, et qui comprend la technologie relative aux polices de caractères, est protégé par un copyright et licencié par des fournisseurs de Sun.

Des parties de ce produit pourront être dérivées du système Berkeley BSD licenciés par l'Université de Californie.

Sun, Sun Microsystems, le logo Sun, Java, JavaServer Pages, Solaris, et StorEdge sont des marques de fabrique ou des marques déposées, de Sun Microsystems, Inc. aux Etats-Unis et dans d'autres pays.

CETTE PUBLICATION EST FOURNIE EN L'ETAT ET AUCUNE GARANTIE, EXPRESSE OU IMPLICITE, N'EST ACCORDEE, Y COMPRIS DES GARANTIES CONCERNANT LA VALEUR MARCHANDE, L'APTITUDE DE LA PUBLICATION A REpondre A UNE UTILISATION PARTICULIERE, OU LE FAIT QU'ELLE NE SOIT PAS CONTREFAISANTE DE PRODUIT DE TIERS. CE DENI DE GARANTIE NE S'APPLIQUERAIT PAS, DANS LA MESURE OU IL SERAIT TENU JURIDIQUEMENT NUL ET NON AVENU.

Table of Contents

Introduction.....	5
Chapter One – Virtual Devices (vdevs), Vdev Labels, and Boot Block.....	6
Section 1.1: Virtual Devices.....	6
Section 1.2: Vdev Labels.....	6
Section 1.2.1: Label Redundancy.....	7
Section 1.2.2: Transactional Two Staged Label Update.....	7
Section 1.3: Vdev Technical Details.....	8
Section 1.3.1: Blank Space.....	8
Section 1.3.2: Boot Block Header.....	8
Section 1.3.3: Name-Value Pair List.....	8
Section 1.3.4: The Uberblock.....	12
Section 1.4: Boot Block.....	14
Chapter Two: Block Pointers and Indirect Blocks.....	15
Section 2.1: DVA – Data Virtual Address.....	15
Section 2.2 : GRID.....	16
Section 2.3: GANG.....	16
Section 2.4: Checksum.....	17
Section 2.5: Compression.....	18
Section 2.6 : Block Size.....	18
Section 2.7: Endian.....	19
Section 2.8: Type.....	19
Section 2.9: Level.....	20
Section 2.10: Fill.....	20
Section 2.11: Birth Transaction.....	21
Section 2.12: Padding.....	21
Chapter Three: Data Management Unit.....	22
Section 3.1 : Objects.....	22
Section 3.2: Object Sets.....	26
Chapter Four – DSL	29
Section 4.1 : DSL Infrastructure.....	29
Section 4.2: DSL Implementation Details.....	31
Section 4.3: Dataset Internals.....	32
Section 4.4: DSL Directory Internals.....	34
Chapter Five – ZAP.....	37
Section 5.1: The Micro Zap.....	38
Section 5.2: The Fat Zap.....	39
Section 5.2.1: zap_phys_t.....	39
Section 5.2.2: Pointer Table.....	41
Section 5.2.3: zap_leaf_phys_t.....	41
Section 5.2.4 : zap_leaf_chunk.....	43
Chapter Six – ZPL.....	45
Section 6.1: ZPL Filesystem Layout.....	45
Section 6.2: Directories and Directory Traversal.....	45
Section 6.3: ZFS Access Control Lists.....	47

Chapter Seven – ZFS Intent Log.....	51
Section 7.1: ZIL header.....	51
Section 7.2: ZIL blocks.....	52
Chapter Eight – ZVOL (ZFS volume).....	55

Introduction

ZFS is a new filesystem technology that provides immense capacity (128-bit), provable data integrity, always-consistent on-disk format, self-optimizing performance, and real-time remote replication.

ZFS departs from traditional filesystems by eliminating the concept of volumes. Instead, ZFS filesystems share a common storage pool consisting of writeable storage media. Media can be added or removed from the pool as filesystem capacity requirements change. Filesystems dynamically grow and shrink as needed without the need to re-partition underlying storage.

ZFS provides a truly consistent on-disk format, but using a copy on write (COW) transaction model. This model ensures that on disk data is never overwritten and all on disk updates are done atomically.

The ZFS software is comprised of seven distinct pieces: the SPA (Storage Pool Allocator), the DSL (Dataset and Snapshot Layer), the DMU (Data Management Layer), the ZAP (ZFS Attribute Processor), the ZPL (ZFS Posix layer), the ZIL (ZFS Intent Log), and ZVOL (ZFS Volume). The on-disk structures associated with each of these pieces are explained in the following chapters: SPA (Chapters 1 and 2), DSL (Chapter 5), DMU (Chapter 3), ZAP (Chapter 4), ZPL (Chapter 6), ZIL (Chapter 7), ZVOL (Chapter 8).

Chapter One – Virtual Devices (vdevs), Vdev Labels, and Boot Block

Section 1.1: Virtual Devices

ZFS storage pools are made up of a collection of virtual devices. There are two types of virtual devices: physical virtual devices (sometimes called leaf vdevs) and logical virtual devices (sometimes called interior vdevs). A physical vdev, is a writeable media block device (a disk, for example). A logical vdev is a conceptual grouping of physical vdevs.

Vdevs are arranged in a tree with physical vdev existing as leaves of the tree. All pools have a special logical vdev called the “root” vdev which roots the tree. All direct children of the “root” vdev (physical or logical) are called top-level vdevs. The Illustration below shows a tree of vdevs representing a sample pool configuration containing two mirrors. The first mirror (labeled “M1”) contains two disk, represented by “vdev A” and “vdev B”. Likewise, the second mirror “M2” contains two disks represented by “vdev C” and “vdev D”. Vdevs A, B, C, and D are all physical vdevs. “M1” and M2” are logical vdevs; they are also top-level vdevs since they originate from the “root vdev”.

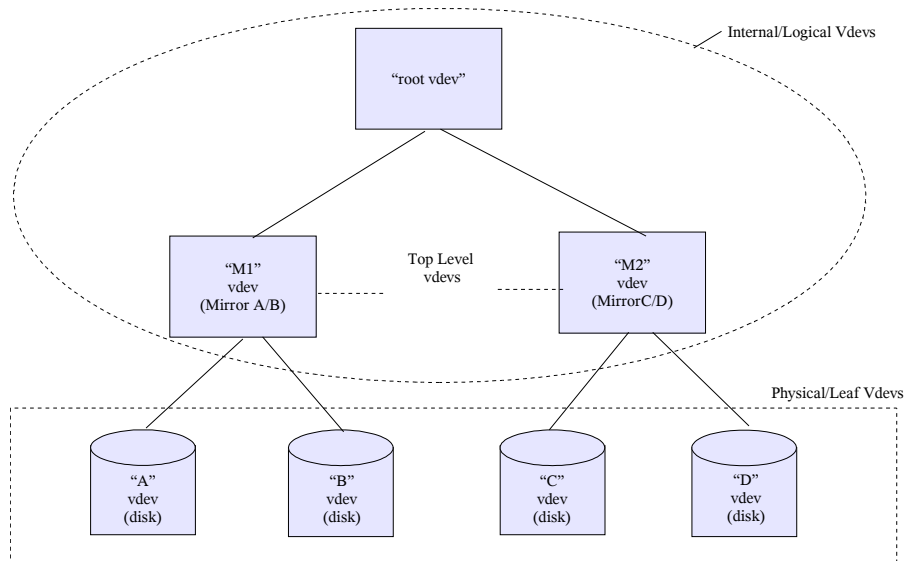

Illustration 1 vdev tree sample configuration

Section 1.2: Vdev Labels

Each physical vdev within a storage pool contains a 256KB structure called a vdev label. The vdev label contains information describing this particular physical vdev and all other vdevs which share a common top-level vdev as an ancestor. For example, the vdev label structure contained on vdev “C”, in the previous illustration, would contain information describing the following vdevs: “C”, “D”, and “M2”. The contents of the vdev label are described in greater detail in section 1.3, *Vdev Technical Details*.

The vdev label serves two purposes: it provides access to a pool's contents and it is used to verify a pool's integrity and availability. To ensure that the vdev label is always available and always valid, redundancy and a staged update model are used. To provide redundancy, four copies of the label are written to each physical vdev within the pool. The four copies are identical within a vdev, but are not identical across vdevs in the pool. During label updates, a two staged transactional approach is used to ensure that a valid vdev label is always available on disk. Vdev label redundancy and the transactional update model are described in more detail below.

Section 1.2.1: Label Redundancy

Four copies of the vdev label are written to each physical vdev within a ZFS storage pool. Aside from the small time frame during label update (described below), these four labels are identical and any copy can be used to access and verify the contents of the pool. When a device is added to the pool, ZFS places two labels at the front of the device and two labels at the back of the device. The drawing below shows the layout of these labels on a device of size N : L0 and L1 represent the front two labels, L2 and L3 represent the back two labels.



Illustration 2 Vdev Label layout on a block device of size N

Based on the assumption that corruption (or accidental disk overwrites) typically occurs in contiguous chunks, placing the labels in non-contiguous locations (front and back) provides ZFS with a better probability that some label will remain accessible in the case of media failure or accidental overwrite (eg. using the disk as a swap device while it is still part of a ZFS storage pool).

Section 1.2.2: Transactional Two Staged Label Update

The location of the vdev labels are fixed at the time the device is added to the pool. Thus, the vdev label does not have copy-on-write semantics like everything else in ZFS. Consequently, when a vdev label is updated, the contents of the label are overwritten. Any time on-disk data is overwritten, there is a potential for error. To ensure that ZFS always has access to its labels, a staged approach is used during update. The first stage of the update writes the even labels (L0 and L2) to disk. If, at any point in time, the system comes down or faults during this update, the odd labels will still be valid. Once the even labels have made it out to stable storage, the odd labels (L1 and L3) are updated and written to disk. This approach has been carefully designed to ensure that a valid copy of the label remains on disk at all times.

Section 1.3: Vdev Technical Details

The contents of a vdev label are broken up into four pieces: 8KB of blank space, 8K of boot header information, 112KB of name-value pairs, and 128KB of 1K sized uberblock structures. The drawing below shows an expanded view of the L0 label. A detailed description of each component follows: blank space (section 1.3.1), boot block header (section 1.3.2), name/value pair list (section 1.3.3), and uberblock array (section 1.3.4).

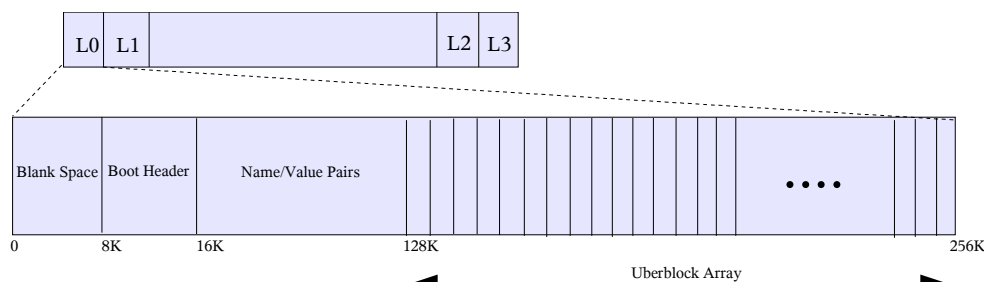

Illustration 3 Components of a vdev label (blank space, boot block header, name/value pairs, uberblock array)

Section 1.3.1: Blank Space

ZFS supports both VTOC (Volume Table of Contents) and EFI disk labels as valid methods of describing disk layout.¹ While EFI labels are not written as part of a slice (they have their own reserved space), VTOC labels must be written to the first 8K of slice 0. Thus, to support VTOC labels, the first 8k of the vdev_label is left empty to prevent potentially overwriting a VTOC disk label.

Section 1.3.2: Boot Block Header

The boot block header is an 8K structure that is reserved for future use. The contents of this block will be described in a future appendix of this paper.

Section 1.3.3: Name-Value Pair List

The next 112KB of the label holds a collection of name-value pairs describing this vdev and all of its related vdevs. Related vdevs are defined as all vdevs within the subtree rooted at this vdev's top-level vdev. For example, the vdev label on device "A" (seen in the illustration below) would contain information describing the subtree highlighted: including vdevs "A", "B", and "M1" (top-level vdev).

¹ Disk labels describe disk partition and slice information. See `fdisk(1M)` and/or `format(1M)` for more information on disk partitions and slices. It should be noted that disk labels are a completely separate entity from vdev labels and while their naming is similar, they should not be confused as being similar.

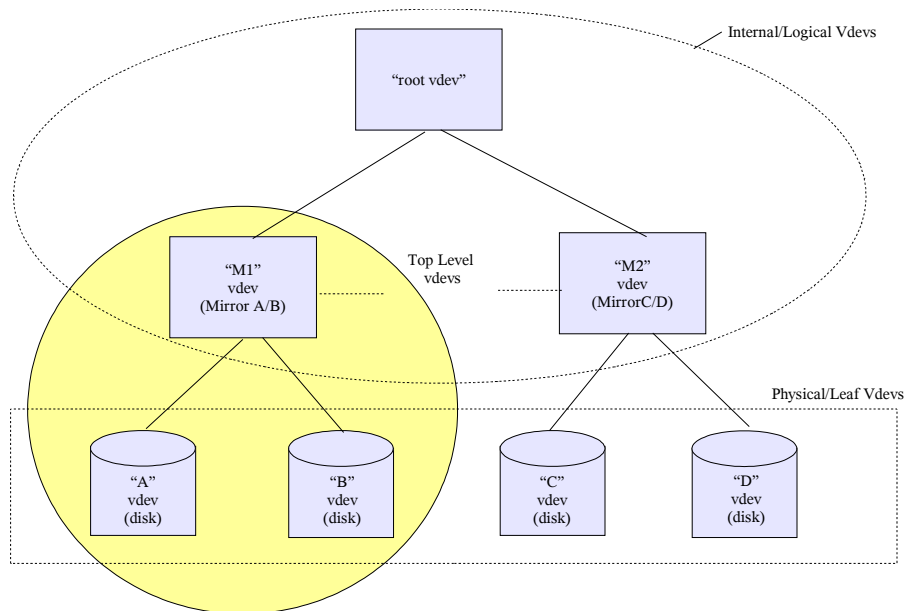

Illustration 4 vdev tree showing related vdevs in highlighted circle

All name-value pairs are stored in XDR encoded nvlsts. For more information on XDR encoding or nvlsts, see the `libnvpair(3LIB)` and `nvlist_free(3NVPAIR)` man pages. The following name-value pairs are contained within this 112KB portion of the `vdev_label`.

Version:

Name: "version"

Value: `DATA_TYPE_UINT64`

Description: On disk format version. Current value is "1".

Name:

Name: "name"

Value: `DATA_TYPE_STRING`

Description: Name of the pool in which this vdev belongs.

State:

Name: "state"

Value: `DATA_TYPE_UINT64`

Description: State of this pool. The following table shows all existing pool states.

<i>State</i>	<i>Value</i>
POOL_STATE_ACTIVE	0
POOL_STATE_EXPORTED	1
POOL_STATE_DESTROYED	2

Table 1 Pool states and values.

Transaction

Name: “txg”

Value: DATA_TYPE_UINT64

Descriptions: Transaction group number in which this label was written to disk.

Pool Guid

Name: “pool_guid”

Value: DATA_TYPE_UINT64

Description: Global unique identifier (guid) for the pool.

Top Guid

Name: “top_guid”

Value: DATA_TYPE_UINT64

Description: Global unique identifier for the top-level vdev of this subtree.

Guid

Name: “guid”

Value: DATA_TYPE_UINT64

Description: Global unique identifier for this vdev.

Vdev Tree

Name: “vdev_tree”

Value: DATA_TYPE_NVLIST

Description: The vdev_tree is a nvlist structure which is used recursively to describe the hierarchical nature of the vdev tree as seen in illustrations one and four. The vdev_tree recursively describes each “related” vdev within this vdev's subtree. The illustration below shows what the “vdev_tree” entry might look like for “vdev A” as shown in illustrations one and four earlier in this document.

```

type='mirror'                                vdev_tree
id=1
guid=16593009660401351626
metaslab_array = 13
metaslab_shift = 22
ashift = 9
asize = 519569408
children[0]
  type='disk'                                vdev_tree
  id=2
  guid=6649981596953412974
  path='/dev/dsk/c4t0d0'
  devid='id1.sd@SSEAGATE_ST373453LW_3HW0J0FJ00007404E4NS/a'
children[1]
  type='disk'                                vdev_tree
  id=3
  guid=3648040300193291405
  path='/dev/dsk/c4t1d0'
  devid='id1.sd@SSEAGATE_ST373453LW_3HW0HLAW0007404D6MN/a'

```

Illustration 5 vdev tree nvlist entry for "vdev A" as seen in Illustrations 1 and 4

Each vdev_tree nvlist contains the following elements as described in the section below. Note that not all nvlist elements are applicable to all vdevs types. Therefore, a vdev_tree nvlist may contain only a subset of the elements described below.

Name: "type"
 Value: DATA_TYPE_STRING
 Description: String value indicating type of vdev. The following vdev_types are valid.

Type	Description
"disk"	Leaf vdev: block storage
"file"	Leaf vdev: file storage
"mirror"	Interior vdev: mirror
"raidz"	Interior vdev: raidz
"replacing"	Interior vdev: a slight variation on the mirror vdev; used by ZFS when replacing one disk with another
"root"	Interior vdev: the root of the vdev tree

Table 2 Vdev Type Strings

Name: "id"
 Value: DATA_TYPE_UINT64
 Description: The id is the index of this vdev in its parent's children array.

Name: "guid"
 Value: DATA_TYPE_UINT64
 Description: Global Unique Identifier for this vdev_tree element.

Name: “path”
Value: DATA_TYPE_STRING
Description: Device path. Only used for leaf vdevs.

Name: “devid”
Value: DATA_TYPE_STRING
Description: Device ID for this vdev_tree element. Only used for vdevs of type disk.

Name: “metaslab_array”
Value: DATA_TYPE_UINT64
Description: Object number of an object containing an array of object numbers. Each element of this array (ma[i]) is, in turn, an object number of a space map for metaslab 'i'.

Name: “metaslab_shift”
Value: DATA_TYPE_UINT64
Description: log base 2 of the metaslab size

Name: “ashift”
Value: DATA_TYPE_UINT64
Description: Log base 2 of the minimum allocatable unit for this top level vdev. This is currently '10' for a RAIDz configuration, '9' otherwise.

Name: “asize”
Value: DATA_TYPE_UINT64
Description: Amount of space that can be allocated from this top level vdev

Name: “children”
Value: DATA_TYPE_NVLIST_ARRAY
Description: Array of vdev_tree nvlists for each child of this vdev_tree element.

Section 1.3.4: The Uberblock

Immediately following the nvpair lists in the vdev label is an array of uberblocks. The uberblock is the portion of the label containing information necessary to access the contents of the pool². Only one uberblock in the pool is active at any point in time. The uberblock with the highest transaction group number and valid SHA-256 checksum is the active uberblock.

To ensure constant access to the active uberblock, the active uberblock is never

² The uberblock is similar to the superblock in UFS.

overwritten. Instead, all updates to an uberblock are done by writing a modified uberblock to another element of the uberblock array. Upon writing the new uberblock, the transaction group number and timestamps are incremented thereby making it the new active uberblock in a single atomic action. Uberblocks are written in a round robin fashion across the various vdevs with the pool. The illustration below has an expanded view of two uberblocks within an uberblock array.

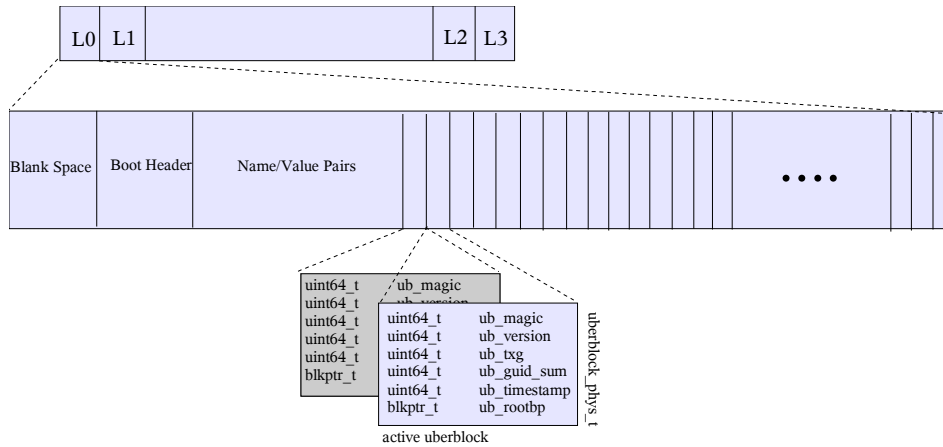

Illustration 6 Uberblock array showing uberblock contents

Uberblock Technical Details

The uberblock is stored in the machine's native endian format and has the following contents:

ub_magic

The uberblock magic number is a 64 bit integer used to identify a device as containing ZFS data. The value of the ub_magic is 0x00bab10c (oo-ba-block). The following table shows the ub_magic number as seen on disk.

<i>Machine Endianness</i>	<i>Uberblock Value</i>
Big Endian	0x00bab10c
Little Endian	0x0cb1ba00

Table 3 Uberblock values per machine endian type.

ub_version

The version field is used to identify the on-disk format in which this data is laid out. The current on-disk format version number is **0x1**. This field contains the same value as the “version” element of the name/value pairs described in section 1.3.3.

ub_txg

All writes in ZFS are done in transaction groups. Each group has an associated transaction group number. The `ub_txg` value reflects the transaction group in which this uberblock was written. The `ub_txg` number must be greater than or equal to the “txg” number stored in the nvlist for this label to be valid.

ub_guid_sum

The `ub_guid_sum` is used to verify the availability of vdevs within a pool. When a pool is opened, ZFS traverses all leaf vdevs within the pool and totals a running sum of all the GUIDs (a vdev's guid is stored in the `guid` nvpair entry, see section 1.3.3) it encounters. This computed sum is checked against the `ub_guid_sum` to verify the availability of all vdevs within this pool.

ub_timestamp

Coordinated Universal Time (UTC) when this uberblock was written in seconds since January 1st 1970 (GMT).

ub_rootbp

The `ub_rootbp` is a `blkptr` structure containing the location of the MOS. Both the MOS and `blkptr` structures are described in later chapters of this document: Chapters 4 and 2 respectively.

Section 1.4: Boot Block

Immediately following the L0 and L1 labels is a 3.5MB chunk reserved for future use. The contents of this block will be described in a future appendix of this paper.

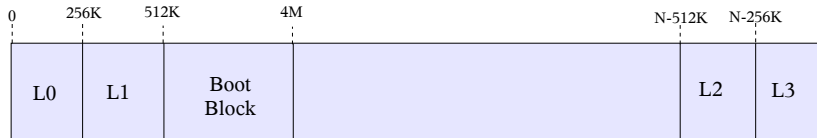

Illustration 7 Vdev label layout including boot block reserved space.

Chapter Two: Block Pointers and Indirect Blocks

Data is transferred between disk and main memory in units called blocks. A block pointer (`blkptr_t`) is a 128 byte ZFS structure used to physically locate, verify, and describe blocks of data on disk.

The 128 byte `blkptr_t` structure layout is shown in the illustration below.

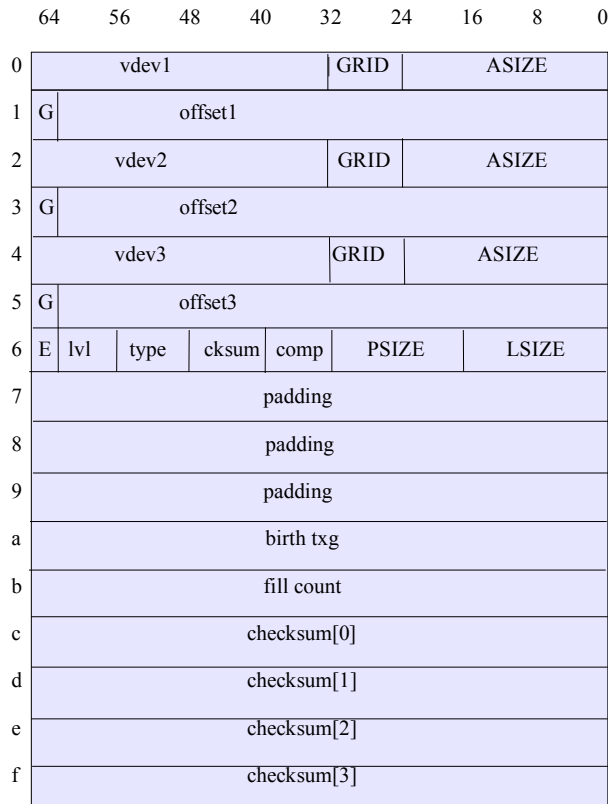

Illustration 8 Block pointer structure showing byte by byte usage.

Section 2.1: DVA – Data Virtual Address

The data virtual address is the name given to the combination of the `vdev` and `offset` portions of the block pointer, for example the combination of `vdev1` and `offset1` make up a DVA (`dva1`). ZFS provides the capability of storing up to three copies of the data pointed to by the block pointer, each pointed to by a unique DVA (`dva1`, `dva2`, or `dva3`). The data stored in each of these copies is identical. The number of DVAs used per block pointer is purely a policy decision and is called the “wideness” of the block pointer:

single wide block pointer (1 DVA), double wide block pointer (2 DVAs), and triple wide block pointer (3 DVAs).

The *vdev* portion of each DVA is a 32 bit integer which uniquely identifies the vdev ID containing this block. The *offset* portion of the DVA is a 63 bit integer value holding the offset (starting after the vdev labels (L0 and L1) and boot block) within that device where the data lives. Together, the *vdev* and *offset* uniquely identify the block address of the data it points to.

The value stored in *offset* is the offset in terms of sectors (512 byte blocks). To find the physical block byte offset from the beginning of a slice, the value inside *offset* must be shifted over (<<) by 9 ($2^9 = 512$) and this value must be added to 0x400000 (size of two vdev_labels and boot block).

$$physical\ block\ address = (offset \ll 9) + 0x400000\ (4MB)$$

Section 2.2 : GRID

Raid-Z layout information, reserved for future use.

Section 2.3: GANG

A gang block is a block whose contents contain block pointers. Gang blocks are used when the amount of space requested is not available in a contiguous block. In a situation of this kind, several smaller blocks will be allocated (totaling up to the size requested) and a gang block will be created to contain the block pointers for the allocated blocks. A pointer to this gang block is returned to the requester, giving the requester the perception of a single block.

Gang blocks are identified by the “G” bit.

<i>“G” bit value</i>	<i>Description</i>
0	non-gang block
1	gang block

Table 4 Gang Block Values

Gang blocks are 512 byte sized, self checksumming blocks. A gang block contains up to 3 block pointers followed by a 32 byte checksum. The format of the gang block is described by the following structures.

```
typedef struct zio_gbh {
    blkptr_t      zg_blkptr[SPA_GBH_NBLKPTRS];
    uint64_t      zg_filler[SPA_GBH_FILLER];
    zio_block_tail_t zg_tail;
} zio_gbh_phys_t;
```

zg_blkptr: array of block pointers. Each 512 byte gang block can hold up to 3 block pointers.

zg_filler: The filler fields pads out the gang block so that it is nicely byte aligned.

```
typedef struct zio_block_tail {
    uint64_t zbt_magic;
    zio_cksum_t zbt_cksum;
}
```

zbt_magic: ZIO block tail magic number. The value is *0x210da7ab10c7a11* (*zio-data-bloc-tail*).

```
typedef zio_cksum {
    uint64_t zc_word[4];
} zio_cksum_t;
```

zc_word: four 8 byte words containing the checksum for this gang block.

Section 2.4: Checksum

By default ZFS checksums all of its data and metadata. ZFS supports several algorithms for checksumming including fletcher2, fletcher4 and SHA-256 (256-bit Secure Hash Algorithm in FIPS 180-2, available at <http://csrc.nist.gov/cryptval>). The algorithm used to checksum this block is identified by the 8 bit integer stored in the *cksum* portion of the block pointer. The following table pairs each integer with a description and algorithm used to checksum this block's contents.

<i>Description</i>	<i>Value</i>	<i>Algorithm</i>
on	1	fletcher2
off	2	none
label	3	SHA-256
gang header	4	SHA-256
zilog	5	fletcher2
fletcher2	6	fletcher2
fletcher4	7	fletcher4
SHA-256	8	SHA-256

Table 5 Checksum Values and associated checksum algorithms.

A 256 bit checksum of the data is computed for each block using the algorithm identified in *cksum*. If the *cksum* value is 2 (off), a checksum will not be computed and *checksum[0]*, *checksum[1]*, *checksum[2]*, and *checksum[3]* will be zero. Otherwise, the 256 bit checksum computed for this block is stored in the *checksum[0]*, *checksum[1]*, *checksum[2]*, and *checksum[3]* fields.

Note: The computed checksum is always of the data, even if this is a gang block. Gang blocks (see above) and zilog blocks (see Chapter 7) are self checksumming.

Section 2.5: Compression

ZFS supports several algorithms for compression. The type of compression used to compress this block is stored in the *comp* portion of the block pointer.

<i>Description</i>	<i>Value</i>	<i>Algorithm</i>
on	1	lzjb
off	2	none
lzjb	3	lzjb

Table 6 Compression Values and associated algorithm.

Section 2.6 : Block Size

The size of a block is described by three different fields in the block pointer; *psize*, *lsize*, and *asize*.

lsize: Logical size. The size of the data without compression, raidz or gang overhead.

psize: physical size of the block on disk after compression

asize: allocated size, total size of all blocks allocated to hold this data including any gang headers or raid-Z parity information

If compression is turned off and ZFS is not on Raid-Z storage, lsize, asize, and psize will all be equal.

All sizes are stored as the number of 512 byte sectors (minus one) needed to represent the size of this block.

Section 2.7: Endian

ZFS is an adaptive-endian filesystem (providing the restrictions described in Chapter One) that allows for moving pools across machines with different architectures: little endian vs. big endian. The “E” portion of the block pointer indicates which format this block has been written out in. Block are always written out in the machine's native endian format.

<i>Endian</i>	<i>Value</i>
Little Endian	1
Big Endian	0

Table 7 Endian Values

If a pool is moved to a machine with a different endian format, the contents of the block are byte swapped on read.

Section 2.8: Type

The *type* portion of the block pointer indicates what type of data this block holds. The *type* can be the following values. More detail is provided in chapter 3 regarding object types.

<i>Type</i>	<i>Value</i>
DMU_OT_NONE	0
DMU_OT_OBJECT_DIRECTORY	1
DMU_OT_OBJECT_ARRAY	2
DMU_OT_PACKED_NVLIST	3
DMU_OT_NVLIST_SIZE	4
DMU_OT_BPLIST	5
DMU_OT_BPLIST_HDR	6
DMU_OT_SPACE_MAP_HEADER	7
DMU_OT_SPACE_MAP	8
DMU_OT_INTENT_LOG	9
DMU_OT_DNODE	10
DMU_OT_OBJSET	11
DMU_OT_DSL_DATASET	12
DMU_OT_DSL_DATASET_CHILD_MAP	13
DMU_OT_OBJSET_SNAP_MAP	14
DMU_OT_DSL_PROPS	15
DMU_OT_DSL_OBJSET	16
DMU_OT_ZNODE	17
DMU_OT_ACL	18
DMU_OT_PLAIN_FILE_CONTENTS	19
DMU_OT_DIRECTORY_CONTENTS	20
DMU_OT_MASTER_NODE	21
DMU_OT_DELETE_QUEUE	22
DMU_OT_ZVOL	23
DMU_OT_ZVOL_PROP	24

Table 8 Object Types

Section 2.9: Level

The *level* portion of the block pointer is the number of levels (number of block pointers which need to be traversed to arrive at this data.). See Chapter 3 for a more complete definition of level.

Section 2.10: Fill

The fill count describes the number of non-zero block pointers under this block pointer. The fill count for a data block pointer is 1, as it does not have any block pointers beneath it.

The fill count is used slightly differently for block pointers of type DMU_OT_DNODE. For block pointers of this type, the fill count contains

the number of free dnodes beneath this block pointer. For more information on dnodes see Chapter 3.

Section 2.11: Birth Transaction

The birth transaction stored in the “birth txg” block pointer field is a 64 bit integer containing the transaction group number in which this block pointer was allocated.

Section 2.12: Padding

The three padding fields in the block pointer are space reserved for future use.

Chapter Three: Data Management Unit

The Data Management Unit (DMU) consumes blocks and groups them into logical units called objects. Objects can be further grouped by the DMU into object sets. Both objects and object sets are described in this chapter.

Section 3.1 : Objects

With the exception of a small amount of infrastructure, described in chapters 1 and 2, everything in ZFS is an object. The following table lists existing ZFS object types; many of these types are described in greater detail in future chapters of this document.

<i>Type</i>	<i>Description</i>
DMU_OT_NONE	Unallocated object
DMU_OT_OBJECT_DIRECTORY	DSL object directory ZAP object
DMU_OT_OBJECT_ARRAY	Object used to store an array of object numbers.
DMU_OT_PACKED_NVLIST	Packed nvlist object.
DMU_OT_SPACE_MAP	SPA disk block usage list.
DMU_OT_INTENT_LOG	Intent Log
DMU_OT_DNODE	Object of dnodes (metadnode)
DMU_OT_OBJSET	Collection of objects.
DMU_OT_DSL_DATASET_CHILD_MAP	DSL ZAP object containing child DSL directory information.
DMU_OT_DSL_OBJSET_SNAP_MAP	DSL ZAP object containing snapshot information for a dataset.
DMU_OT_DSL_PROPS	DSL ZAP properties object containing properties for a DSL dir object.
DMU_OT_BPLIST	Block pointer list – used to store the “deadlist” : list of block pointers deleted since the last snapshot, and the “deferred free list” used for sync to convergence.
DMU_OT_BPLIST_HDR	BPLIST header: stores the bplist_phys_t structure.
DMU_OT_ACL	ACL (Access Control List) object
DMU_OT_PLAIN_FILE	ZPL Plain file
DMU_OT_DIRECTORY_CONTENTS	ZPL Directory ZAP Object
DMU_OT_MASTER_NODE	ZPL Master Node ZAP object: head object used to identify root directory, delete queue, and version for a filesystem.

<i>Type</i>	<i>Description</i>
DMU_OT_DELETE_QUEUE	The delete queue provides a list of deletes that were in-progress when the filesystem was force unmounted or as a result of a system failure such as a power outage. Upon the next mount of the filesystem, the delete queue is processed to remove the files/dirs that are in the delete queue. This mechanism is used to avoid leaking files and directories in the filesystem.
DMU_OT_ZVOL	ZFS volume (ZVOL)
DMU_OT_ZVOL_PROP	ZVOL properties

Table 9 DMU Object Types

Objects are defined by 512 bytes structures called dnodes³. A dnode describes and organizes a collection of blocks making up an object. The dnode (`dnode_phys_t` structure), seen in the illustration below, contains several fixed length fields and two variable length fields. Each of these fields are described in detail below.

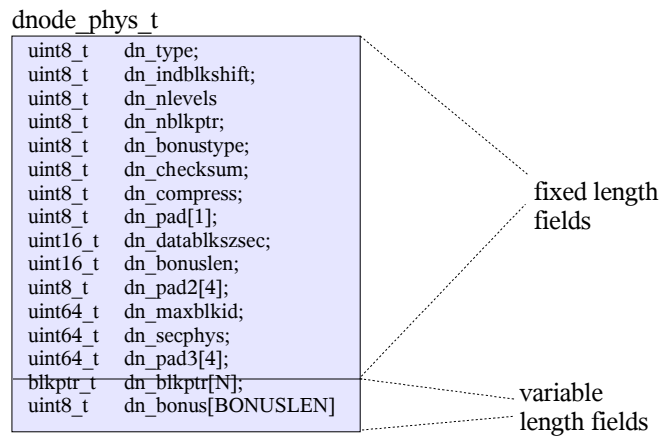

Illustration 9 `dnode_phys_t` structure

dn_type

An 8-bit numeric value indicating an object's type. See Table 8 for a list of valid object types and their associated 8 bit identifiers.

dn_indblkshift and **dn_datablkszsec**

ZFS supports variable data and indirect (see `dn_nlevels` below for a description of indirect blocks) block sizes ranging from 512 bytes to 128 Kbytes.

³ A dnode is similar to an inode in UFS.

dn_indblks: 8-bit numeric value containing the log (base 2) of the size (in bytes) of an indirect block for this object.

dn_datablksize: 16-bit numeric value containing the data block size (in bytes) divided by 512 (size of a disk sector). This value can range between 1 (for a 512 byte block) and 256 (for a 128 Kbyte block).

dn_nblkptr and dn_blkptr

dn_blkptr is a variable length field that contains between one and three block pointers. The number of block pointers that the dnode contains is set at object allocation time and remains constant throughout the life of the dnode.

dn_nblkptr : 8 bit numeric value containing the number of block pointers in this dnode.

dn_blkptr: block pointer array containing *dn_nblkptr* block pointers

dn_nlevels

dn_nlevels is an 8 bit numeric value containing the number of levels that make up this object. These levels are often referred to as levels of indirection.

Indirection

A dnode has a limited number (*dn_nblkptr*, see above) of block pointers to describe an object's data. For a dnode using the largest data block size (128KB) and containing the maximum number of block pointers (3), the largest object size it can represent (without indirection) is 384 KB: $3 \times 128\text{KB} = 384\text{KB}$. To allow for larger objects, indirect blocks are used. An indirect block is a block containing block pointers. The number of block pointers that an indirect block can hold is dependent on the indirect block size (represented by *dn_indblks*) and can be calculated by dividing the indirect block size by the size of a blkptr (128 bytes). The largest indirect block (128KB) can hold up to 1024 block pointers. As an object's size increases, more indirect blocks and levels of indirection are created. A new level of indirection is created once an object grows so large that it exceeds the capacity of the current level. ZFS provides up to six levels of indirection to support files up to 2^{64} bytes long.

The illustration below shows an object with 3 levels of blocks (level 0, level 1, and level 2). This object has triple wide block pointers (*dva1*, *dva2*, and *dva3*) for metadata and single wide block pointers for its data (see Chapter two for a description of block pointer wideness). The blocks at level 0 are data blocks.

dnnode_phys_t

uint8_t	dn_type;
uint8_t	dn_indblkshift;
uint8_t	dn_nlevels = 3
uint8_t	dn_nblkptr = 3
uint8_t	dn_bonustype;
uint8_t	dn_checksum;
uint8_t	dn_compress;
uint8_t	dn_pad[1];
uint16_t	dn_datablksize;
uint16_t	dn_bonuslen;
uint8_t	dn_pad2[4];
uint64_t	dn_maxblkid;
uint64_t	dn_secphys;
uint64_t	dn_pad3[4];
blkptr_t	dn_blkptr[3];
uint8_t	dn_bonus[BONUSLEN]

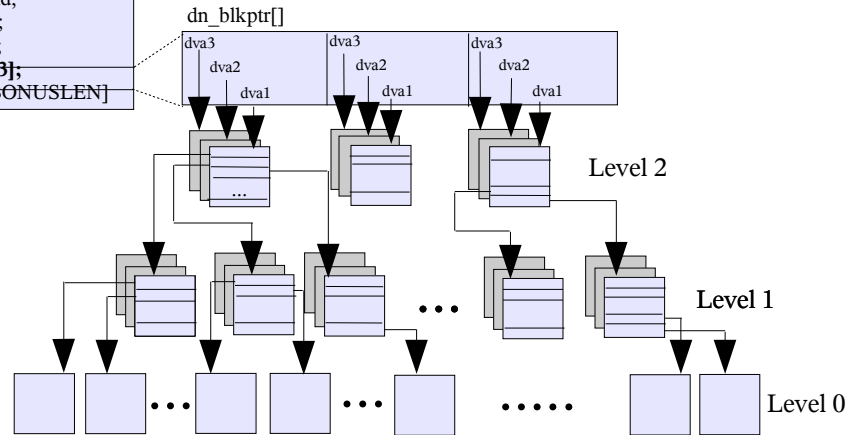

Illustration 10 Object with 3 levels. Triple wide block pointers used for metadata; single wide block pointers used for data.

dn_maxblkid

An object's blocks are identified by block ids. The blocks in each level of indirection are numbered from 0 to N, where the first block at a given level is given an id of 0, the second an id of 1, and so forth.

The *dn_maxblkid* field in the dnode is set to the value of the largest data (level zero) block id for this object.

Note on Block Ids: Given a block id and level, ZFS can determine the exact branch of indirect blocks which contain the block. This calculation is done using the block id, block level, and number of block pointers in an indirect block. For example, take an object which has 128KB sized indirect blocks. An indirect block of this size can hold 1024 block pointers. Given a level 0 block id of 16360, it can be determined that block 15 (block id 15) of level 1 contains the block pointer for level 0 blkid 16360.

$$\text{level 1 blkid} = 16360 \% 1024 = 15$$

This calculation can be performed recursively up the tree of indirect blocks until the top level of indirection has been reached.

dn_secphys

The sum of all *asize* values for all block pointers (data and indirect) for this object.

dn_bonus, dn_bonuslen, and dn_bonustype

The bonus buffer (*dn_bonus*) is defined as the space following a dnode's block pointer array (*dn_blkptr*). The amount of space is dependent on object type and can range between 64 and 320 bytes.

dn_bonus: *dn_bonuslen* sized chunk of data . The format of this data is defined by *dn_bonustype*.

dn_bonuslen: Length (in bytes) of the bonus buffer.

dn_bonustype: 8 bit numeric value identifying the type of data contained within the bonus buffer. The following table shows valid bonus buffer types and the structures which are stored in the bonus buffer. The contents of each of these structures will be discussed later in this specification.

<i>Bonus Type</i>	<i>Description</i>	<i>Metadata Structure</i>	<i>Value</i>
DMU_OT_PACKED_NVLIST_SIZE	Bonus buffer type containing size in bytes of a DMU_OT_PACKED_NVLIST object.	uint64_t	4
DMU_OT_SPACE_MAP_HEADER	Spa space map header.	space_map_obj_t	7
DMU_OT_DSL_DIR	DSL Directory object used to define relationships and properties between related datasets.	dsl_dir_phys_t	12
DMU_OT_DSL_DATASET	DSL dataset object used to organize snapshot and usage static information for objects of type DMU_OT_OBJSET.	dsl_dataset_phys_t	16
DMU_OT_ZNODE	ZPL metadata	znode_phys_t	17

Table 10 Bonus Buffer Types and associated structures.

Section 3.2: Object Sets

The DMU organizes objects into groups called object sets. Object sets are used in ZFS to group related objects, such as objects in a filesystem, snapshot, clone, or volume.

Object sets are represented by a 1K byte *objset_phys_t* structure. Each member of this structure is defined in detail below.

objset_phys_t

```
dnode_phys_t metadnode
zil_header_t os_zil_header
uint64_t os_type
```

Illustration 11 objset_phys_t structure

os_type

The DMU supports several types of object sets, where each object set type has its own well defined format/layout for its objects. The object set's type is identified by a 64 bit integer, *os_type*. The table below lists available DMU object set types and their associated *os_type* integer value.

<i>Object Set Type</i>	<i>Description</i>	<i>Value</i>
DMU_OST_NONE	Uninitialized Object Set	0
DMU_OST_META	DSL Object Set , See Chapter 4	1
DMU_OST_ZFS	ZPL Object Set, See Chapter 6	2
DMU_OST_ZVOL	ZVOL Object Set, See Chapter 8	3

Table 11 DMU Object Set Types

os_zil_header

The ZIL header is described in detail in Chapter 7 of this document.

metadnode

As described earlier in this chapter, each object is described by a *dnode_phys_t*. The collection of *dnode_phys_t* structures describing the objects in this object set are stored as an object pointed to by the metadnode. The data contained within this object is formatted as an array of *dnode_phys_t* structures (one for each object within the object set).

Each object within an object set is uniquely identified by a 64 bit integer called an object number. An object's "object number" identifies the array element, in the *dnode* array, containing this object's *dnode_phys_t*.

The illustration below shows an object set with the metadnode expanded. The metadnode contains three block pointers, each of which have been expanded to show their contents. Object number 4 has been further expanded to show the details of the *dnode_phys_t* and the block structure referenced by this *dnode*.

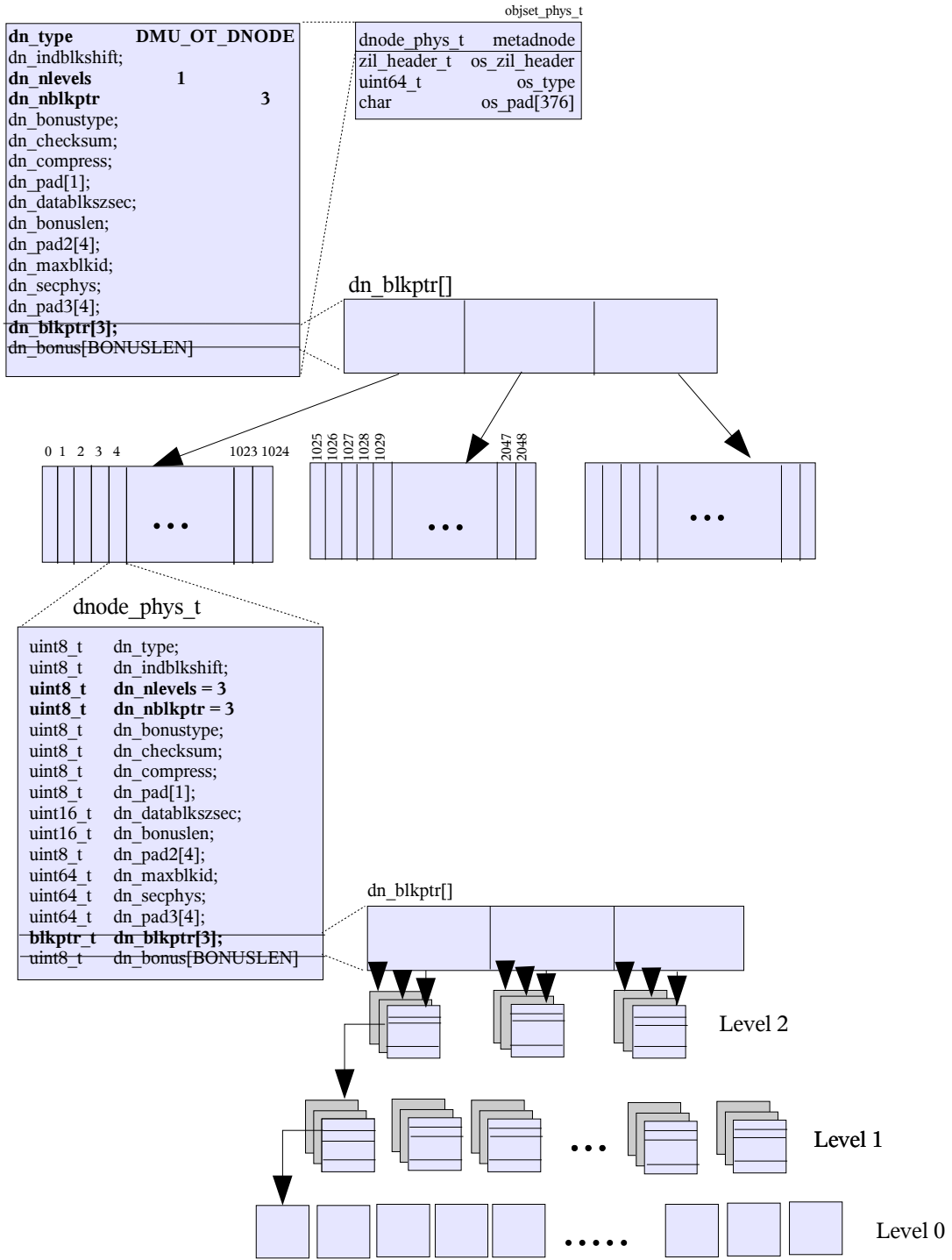

Illustration 12 Object Set

Chapter Four – DSL

The DSL (Dataset and Snapshot Layer) provides a mechanism for describing and managing relationships-between and properties-of object sets. Before describing the DSL and the relationships it describes, a brief overview of the various flavors of object sets is necessary.

Object Set Overview

ZFS provides the ability to create four kinds of object sets: filesystems, clones, snapshots, and volumes.

ZFS filesystem: A filesystem stores and organizes objects in an easily accessible, POSIX compliant manner.

ZFS clone: A clone is identical to a filesystem with the exception of its origin. Clones originate from snapshots and their initial contents are identical to that of the snapshot from which it originated.

ZFS snapshot: A snapshot is a read-only version of a filesystem, clone, or volume at a particular point in time.

ZFS volume: A volume is a logical volume that is exported by ZFS as a block device.

ZFS supports several operations and/or configurations which cause interdependencies amongst object sets. The purpose of the DSL is to manage these relationships. The following is a list of such relationships.

Clones: A clone is related to the snapshot from which it originated. Once a clone is created, the snapshot in which it originated can not be deleted unless the clone is also deleted.

Snapshots: A snapshot is a point-in-time image of the data in the object set in which it was created. A filesystem, clone, or volume can not be destroyed unless its snapshots are also destroyed.

Children: ZFS support hierarchically structured object sets; object sets within object sets. A child is dependent on the existence of its parent. A parent can not be destroyed without first destroying all children.

Section 4.1 : DSL Infrastructure

Each object set is represented in the DSL as a dataset. A dataset manages space consumption statistics for an object set, contains object set location information, and keeps track of any snapshots inter-dependencies.

Datasets are grouped together hierarchically into collections called Dataset Directories.

Dataset Directories manage a related grouping of datasets and the properties associated with that grouping. A DSL directory always has exactly one “active dataset”. All other datasets under the DSL directory are related to the “active” dataset through snapshots, clones, or child/parent dependencies.

The following picture shows the DSL infrastructure including a pictorial view of how object set relationships are described via the DSL datasets and DSL directories. The top level DSL Directory can be seen at the top/center of this figure. Directly below the DSL Directory is the “active dataset”. The active dataset represents the live filesystem. Originating from the active dataset is a linked list of snapshots which have been taken at different points in time. Each dataset structure points to a DMU Object Set which is the actual object set containing object data. To the left of the top level DSL Directory is a child ZAP⁴ object containing a listing of all child/parent dependencies. To the right of the DSL directory is a properties ZAP object containing properties for the datasets within this DSL directory. A listing of all properties can be seen in Table 12 below.

A detailed description of Datasets and DSL Directories are described in the *Dataset Internals* and *DSL Directories Internals* sections below.

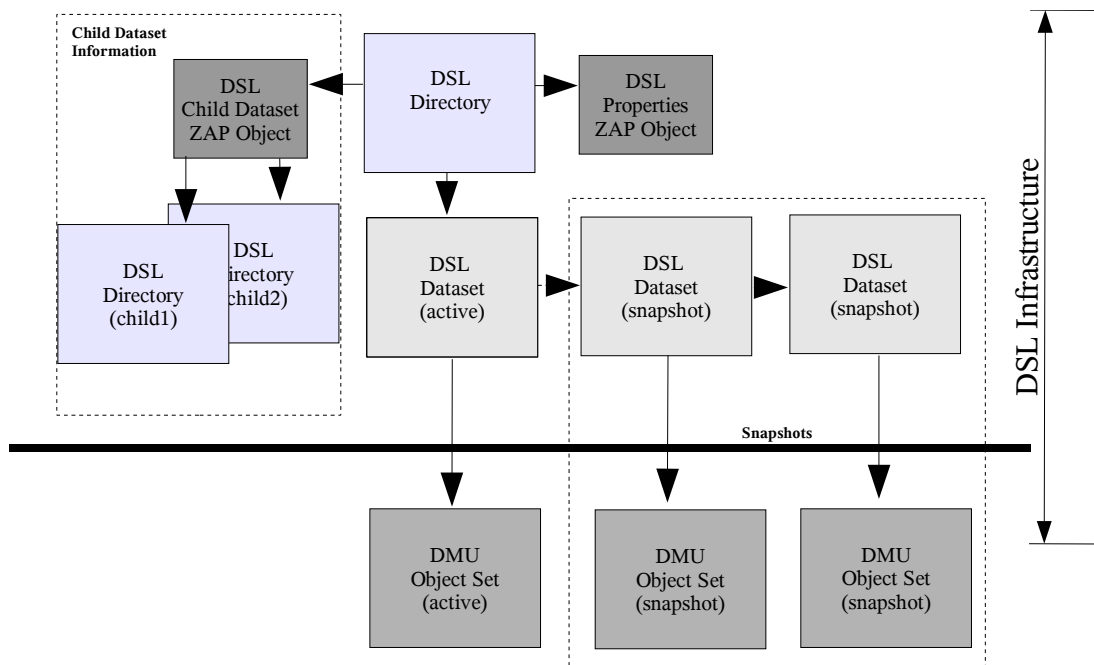

Illustration 13 DSL Infrastructure

4 The ZAP is explained in Chapter 5.

Section 4.2: DSL Implementation Details

The DSL is implemented as an object set of type `DMU_OST_META`. This object set is often called the Meta Object Set, or MOS. There is only one MOS per pool and the uberblock (see Chapter One) points to it directly.

There is a single distinguished object in the Meta Object Set. This object is called the object directory and is always located in the second element of the `dnode` array (index 1). All objects, with the exception of the object directory, can be located by traversing through a set of object references starting at this object.

The object directory

The object directory is a `ZAP` object (an object containing name/value pairs -see chapter 5 for a description of `ZAP` objects) containing three attribute pairs (name/value) named: `root_dataset`, `config`, and `sync_bplist`.

root_dataset: The “`root_dataset`” attribute contains a 64 bit integer value identifying the object number of the root DSL directory for the pool. The root DSL directory is a special object whose contents reference all top level datasets within the pool. The “`root_dataset`” directory, is an object of type `DMU_OT_DSL_DIR` and will be explained in greater detail in *Section 4.4: DSL Directory Internals*.

config: The “`config`” attribute contains a 64 bit integer value identifying the object number for an object of type `DMU_OT_PACKED_NVLIST`. This object contains `XDR_ENCODED` name value pairs describing this pools vdev configuration. Its contents are similar to those described in section 1.3.3: name/value pairs list.

sync_bplist: The “`sync_bplist`” attribute contains a 64 bit integer value identifying the object number for an object of type `DMU_OT_SYNC_BPLIST`. This object contains a list of block pointers which need to be freed during the next transaction.

The illustration below shows the meta object set (MOS) in relation to the uberblock and label structures discussed in Chapter 1.

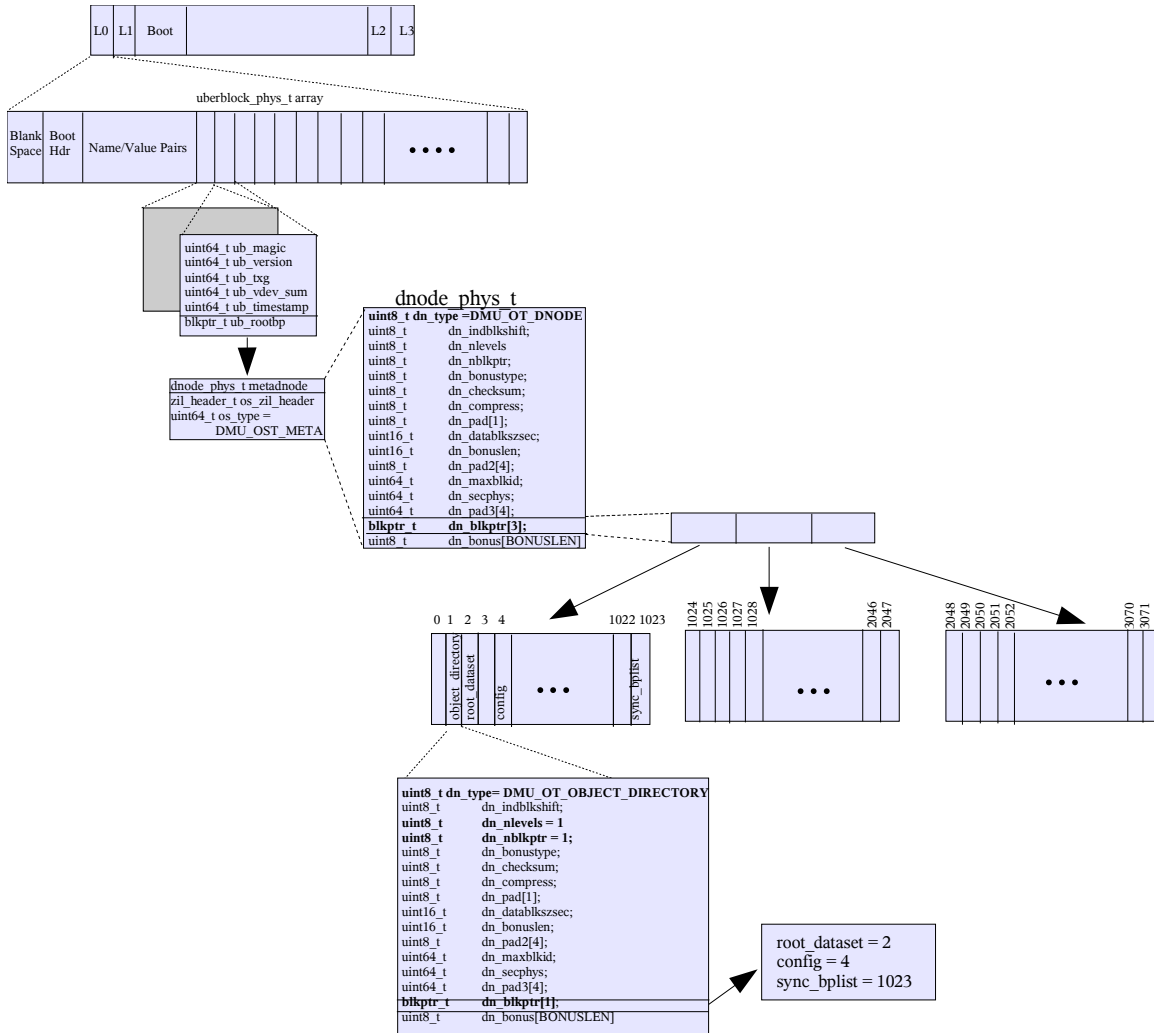

Illustration 14 Meta Object Set

Section 4.3: Dataset Internals

Datasets are stored as an object of type `DMU_OT_DSL_DATASET`. This object type uses the bonus buffer in the `dnode_phys_t` to hold a `dsl_dataset_phys_t` structure. The contents of the `dsl_dataset_phys_t` structure are shown below.

uint64_t ds_dir_obj: Object number of the DSL directory referencing this dataset.

uint64_t ds_prev_snap_obj: If this dataset represents a filesystem, volume, or clone, this field contains the 64 bit object number for the most recent snapshot taken; this field is zero if no snapshots have been taken.

If this dataset represents a snapshot, this field contains the 64 bit object number for the snapshot taken prior to this snapshot. This field is zero if there are no previous

snapshots.

uint64_t ds_prev_snap_txg: The transaction group number when the previous snapshot (pointed to by *ds_prev_snap_obj*) was taken.

uint64_t ds_next_snap_obj: This field is only used for datasets representing snapshots. It contains the object number of the dataset which is the most recent snapshot. This field is always zero for datasets representing clones, volumes, or filesystems.

uint64_t ds_snapnames_zapobj: Object number of a ZAP object (see Chapter 5) containing name value pairs for each snapshot of this dataset. Each pair contains the name of the snapshot and the object number associated with it's DSL dataset structure.

uint64_t ds_num_children: Always zero if not a snapshot. For snapshots, this is the number of references to this snapshot: 1 (from the next snapshot taken, or from the active dataset if no snapshots have been taken) + the number of clones originating from this snapshot.

uint64_t ds_creation_time: Seconds since January 1st 1970 (GMT) when this dataset was created.

uint64_t ds_creation_txg: The transaction group number in which this dataset was created.

uint64_t ds_deadlist_obj: The object number of the deadlist (an array of blkptr's deleted since the last snapshot).

uint64_t ds_used_bytes: unique bytes used by the object set represented by this dataset

uint64_t ds_compressed_bytes: number of compressed bytes in the object set represented by this dataset

uint64_t ds_uncompressed_bytes: number of uncompressed bytes in the object set represented by this dataset

uint64_t ds_unique_bytes:

When a snapshot is taken, its initial contents are identical to that of the active copy of the data. As the data changes in the active copy, more and more data becomes unique to the snapshot (the data diverges from the snapshot). As that happens, the amount of data unique to the snapshot increases. The amount of unique snapshot data is stored in this field: it is zero for clones, volumes, and filesystems.

uint64_t ds_fsid_guid: 64 bit ID that is guaranteed to be unique amongst all

currently open datasets. Note, this ID could change between successive dataset opens.

uint64_t ds_guid: 64 bit global id for this dataset. This value never changes during the lifetime of the object set.

uint64_t ds_restoring: The field is set to “1” if ZFS is in the process of restoring to this dataset through 'zfs restore'⁵

blkptr_t ds_bp: Block pointer containing the location of the object set that this dataset represents.

Section 4.4: DSL Directory Internals

The DSL Directory object contains a *dsl_dir_phys_t* structure in its bonus buffer. The contents of this structure are described in detail below.

uint64_t dd_creation_time: Seconds since January 1st, 1970 (GMT) when this DSL directory was created.

uint64_t dd_head_dataset_obj: 64 bit object number of the active dataset object

uint64_t dd_parent_obj: 64 bit object number of the parent DSL directory

uint64_t dd_clone_parent_obj: For *cloned* object sets, this field contains the object number of snapshot used to create this clone.

uint64_t dd_child_dir_zapobj: Object number of a ZAP object containing name-value pairs for each child of this DSL directory.

uint64_t dd_used_bytes: Number of bytes used by all datasets within this directory: includes any snapshot and child dataset used bytes.

uint64_t dd_compressed_bytes: Number of compressed bytes for all datasets within this DSL directory.

uint64_t dd_uncompressed_bytes: Number of uncompressed bytes for all datasets within this DSL directory.

uint64_t dd_quota: Designated quota, if any, which can not be exceeded by the datasets within this DSL directory.

uint64_t dd_reserved: The amount of space reserved for consumption by the datasets within this DSL directory.

⁵ See the ZFS Admin Guide for information about the zfs command.

uint64_t dd_props_zapobj: 64 bit object number of a ZAP object containing the properties for all datasets within this DSL directory. Only the non-inherited / locally set values are represented in this ZAP object. Default, inherited values are inferred when there is an absence of an entry.

The following table shows valid property values.

<i>Property</i>	<i>Description</i>	<i>Values</i>
aclinherit	Controls inheritance behavior for datasets.	discard = 0 noallow = 1 passthrough = 3 secure = 4 (default)
aclmode	Controls chmod and file/dir creation behavior for datasets.	discard = 0 groupmask = 2 (default) passthrough = 3
atime	Controls whether atime is updated on objects within a dataset .	off = 0 on = 1 (default)
checksum	Checksum algorithm for all datasets within this DSL Directory.	on = 1 (default) off = 0
compression	Compression algorithm for all datasets within this DSL Directory.	on = 1 off = 0 (default)
devices	Controls whether device nodes can be opened on datasets.	devices = 0 nodevices = 1 (default)
exec	Controls whether files can be executed on a dataset.	exec = 1 (default) noexec = 0
mountpoint	Mountpoint path for datasets within this DSL Directory.	string
quota	Limits the amount of space all datasets within a DSL directory can consume.	quota size in bytes or zero for no quota (default)
readonly	Controls whether objects can be modified on a dataset.	readonly = 1 readwrite = 0 (default)
recordsize	Block Size for all objects within the datasets contained in this DSL Directory	recordsize in bytes
reservation	Amount of space reserved for this DSL Directory, including all child datasets and child DSL Directories.	reservation size in bytes

<i>Property</i>	<i>Description</i>	<i>Values</i>
setuid	Controls whether the set-UID bit is respected on a dataset.	setuid = 1 (default) nosetuid = 0
share nfs	Controls whether the datasets in a DSL Directory are shared by NFS.	string – any valid nfs share options
snapdir	Controls whether .zfs is hidden or visible in the root filesystem.	hidden = 0 visible = 1 (default)
volblocksize	For volumes, specifies the block size of the volume. The <code>blocksize</code> cannot be changed once the volume has been written, so it should be set at volume creation time.	between 512 to 128K, powers of two. Defaults to 8K
volsize	Volume size, only applicable to volumes.	volume size in bytes
zoned	Controls whether a dataset is managed through a local zone.	on = 1 off = 0 (default)

Table 12 Editable Property Values stored in the `dd_props_zabobj`

Chapter Five – ZAP

The ZAP (ZFS Attribute Processor) is a module which sits on top of the DMU and operates on objects called ZAP objects. A ZAP object is a DMU object used to store attributes in the form of name-value pairs. The name portion of the attribute is a zero-terminated string of up to 256 bytes (including terminating NULL). The value portion of the attribute is an array of integers whose size is only limited by the size of a ZAP data block.

ZAP objects are used to store properties for a dataset, navigate filesystem objects, store pool properties and more. The following table contains a list of ZAP object types.

<i>ZAP Object Type</i>
DMU_OT_OBJECT_DIRECTORY
DMU_OT_DSL_DIR_CHILD_MAP
DMU_OT_DSL_DS_SNAP_MAP
DMU_OT_DSL_PROPS
DMU_OT_DIRECTORY_CONTENTS
DMU_OT_MASTER_NODE
DMU_OT_DELETE_QUEUE
DMU_OT_ZVOL_PROP

Table 13 ZAP Object Types

ZAP objects come in two forms; microzap objects and fatzap objects. Microzap objects are a lightweight version of the fatzap and provide a simple and fast lookup mechanism for a small number of attribute entries. The fatzap is better suited for ZAP objects containing large numbers of attributes.

The following guidelines are used by ZFS to decide whether or not to use a fatzap or a microzap object.

A microzap object is used if all three conditions below are met:

- all name-value pair entries fit into one block. The maximum data block size in ZFS is 128KB and this size block can fit up to 2047 microzap entries.
- The value portion of all attributes are of type `uint64_t`.
- The name portion of each attribute is less than or equal to 50 characters in length (including NULL terminating character).

If any of the above conditions are not met, a fatzap object is used.

The first 64 bit word in each block of a ZAP object is used to identify the type of ZAP contents contained within this block. The table below shows these values.

<i>Identifier</i>	<i>Description</i>	<i>Value</i>
ZBT_MICRO	This block contains microzap entries	(1ULL << 63) + 3
ZBT_HEADER	This block is used for the fatzap. This identifier is only used for the first block in a fatzap object.	(1ULL << 63) + 1
ZBT_LEAF	This block is used for the fatzap. This identifier is used for all blocks in the fatzap with the exception of the first.	(1ULL << 63) + 0

Table 14 ZAP Object Block Types

Section 5.1: The Micro Zap

The microzap implements a simple mechanism for storing a small number of attributes. A microzap object consists of a single block containing an array of microzap entries (*mzap_ent_phys_t* structures). Each attribute stored in a microzap object is represented by one of these microzap entry structures.

A microzap block is laid out as follows: the first 128 bytes of the block contain a microzap header structure called the *mzap_phys_t*. This structure contains a 64 bit ZBT_MICRO value indicating that this block is used to store microzap entries. Following this value is a 64 bit *salt* value that is stirred into the hash so that the hash function is different for each ZAP object. The next 42 bytes of this header is intentionally left blank and the last 64 bytes contain the first microzap entry (a structure of type *mzap_ent_phys_t*). The remaining bytes in this block are used to store an array of *mzap_ent_phys_t* structures. The illustration below shows the layout of this block.

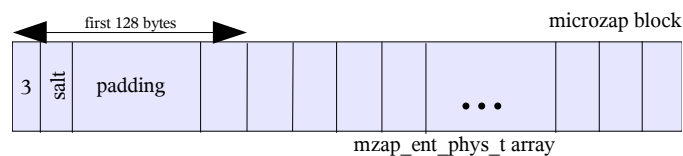

Illustration 15 Microzap block layout

The *mzap_ent_phys_t* structure and associated #defines are shown below.

```
#define MZAP_ENT_LEN      64
#define MZAP_NAME_LEN    (MZAP_ENT_LEN - 8 - 4 - 2)

typedef struct mzap_ent_phys {
    uint64_t mze_value;
    uint32_t mze_cd;
    uint16_t mze_pad;
    char mze_name[MZAP_NAME_LEN];
} mzap_ent_phys_t;
```

mze_value: 64 bit integer
mze_cd: 32 bit collision differentiator (“CD”): associated with an entry whose hash value is the same as another entry within this ZAP object. When an entry is inserted into the ZAP object, the lowest CD which is not already used by an entry with the same hash value is assigned. In the absence of hash collisions, the CD value will be zero.
mze_pad: reserved for future use
mze_name: NULL terminated string less than or equal to 50 characters in length

Section 5.2: The Fat Zap

The fatzap implements a flexible architecture for storing large numbers of attributes, and/or attributes with long names or complex values (not `uint64_t`). This section begins with an explanation of the basic structure of a fatzap object and is followed by a detailed explanation of each component of a fatzap object.

All entries in a fatzap object are arranged based on a 64 bit hash of the attribute's name. The hash is used to index into a pointer table (as can be seen on the left side of the illustration below). The number of bits used to index into this table (sometimes called the *prefix*) is dependent on the number of entries in the table. The number of entries in the table can change over time. As policy stands today, the pointer table will grow if the number of entries hashing to a particular bucket exceeds the capacity of one leaf block (explained in detail below). The pointer table entries reference a chain of fatzap blocks called leaf blocks, represented by the `zap_leaf_phys` structure. Each leaf block is broken up into some number of chunks (`zap_leaf_chunks`) and each attribute is stored in one or more of these leaf chunks. The illustration below shows the basic fatzap structures, each component is explained in detail in the following sections.

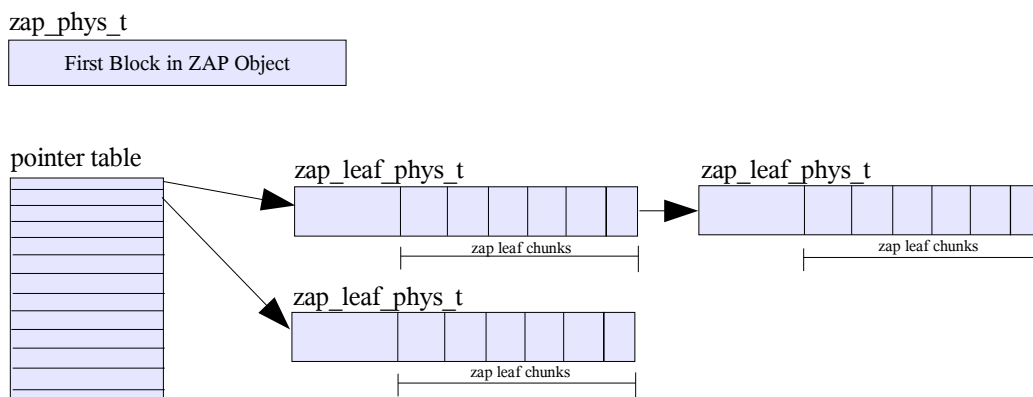

Illustration 16 fatzap structure overview

Section 5.2.1: zap_phys_t

The first block of a fatzap object contains a 128KB `zap_phys_t` structure. Depending on the

size of the pointer table, this structure may contain the pointer table. If the pointer table is too large to fit in the space provided by the `zap_phys_t`, some information about where it can be found is store in the `zap_table_phys` portion of this structure. The definitions of the `zap_phys_t` contents are as follows:

```

zap_phys_t
uint64_t zap_block_type
uint64_t zap_magic
struct zap_table_phys {
    uint64_t zt_blk
    uint64_t zt_numblks
    uint64_t zt_shift
    uint64_t zt_nextblk
    uint64_t zt_blk_copied
} zap_ptrtbl;

uint64_t zap_freeblk
uint64_t zap_num_leafs
uint64_t zap_num_entries
uint64_t zap_salt
uint64_t zap_pad[8181]
uint64_t zap_leafs[8192]

```

Illustration 17 zap_phys_t structure

zap_block_type:

64 bit integer identifying type of ZAP block. Always set to ZBT_HEADER (see Table 14) for the first block in the fatzap.

zap_magic:

64 bit integer containing the ZAP magic number: `0x2F52AB2AB` (*zfs-zap-zap*)

zap_table_phys:

structure whose contents are used to describe the pointer table

zt_blk:

Blkid for the first block of the pointer table. This field is only used when the pointer table is external to the `zap_phys_t` structure; zero otherwise.

zt_numblks:

Number of blocks used to hold the pointer table. This field is only used when the pointer table is external to the `zap_phys_t` structure; zero otherwise.

zt_shift:

Number of bits used from the hash value to index into the pointer table. If the pointer table is contained within the `zap_phys`, this value will be 13.

uint64_t zt_nextblk:

uint64_t zt_blks_copied:

The above two fields are used when the pointer table changes sizes.

zap_freeblk: 64 bit integer containing the first available ZAP block that can be used to allocate a new zap_leaf.

zap_num_leafs:

Number of zap_leaf_phys_t structures (described below) contained within this ZAP object.

zap_salt:

The salt value is a 64 bit integer that is stirred into the hash function, so that the hash function is different for each ZAP object.

zap_num_entries:

Number of attributes stored in this ZAP object.

zap_leafs[8192]:

The zap_leaf array contains 2^{13} (8192) slots. If the pointer table has fewer than 2^{13} entries, the pointer table will be stored here. If not, this field is unused.

Section 5.2.2: Pointer Table

The pointer table is a hash table which uses a chaining method to handle collisions. Each hash bucket contains a 64 bit integer which describes the level zero block id (see Chapter 3 for a description of block ids) of the first element in the chain of entries hashed here. An entries hash bucket is determined by using the first few bits of the 64 bit ZAP entry hash computed from the attribute's name. The value used to index into the pointer table is called the *prefix* and is the *zt_shift* high order bits of the 64 bit computed hash.

Section 5.2.3: zap_leaf_phys_t

The zap_leaf_phys_t is the structure referenced by the pointer table. Collisions in the pointer table result in zap_leaf_phys_t structures being strung together in a link list fashion. The zap_leaf_phys_t structure contains a header, a hash table, and some number of chunks.

```
typedef struct zap_leaf_phys {
    struct zap_leaf_header {
        uint64_t lhr_block_type;
        uint64_t lhr_next;
        uint64_t lhr_prefix;
        uint32_t lhr_magic;
        uint16_t lhr_nfree;
        uint16_t lhr_nentries;
        uint16_t lhr_prefix_len;
        uint16_t lh_freelist;
        uint8_t lh_pad2[12];
    } l_hdr; /* 2 24-byte chunks */
```

```

uint16_t l_hash[ZAP_LEAF_HASH_NUMENTRIES];
union zap_leaf_chunk {
    struct zap_leaf_entry {
        uint8_t le_type;
        uint8_t le_int_size;
        uint16_t le_next;
        uint16_t le_name_chunk;
        uint16_t le_name_length;
        uint16_t le_value_chunk;
        uint16_t le_value_length;
        uint16_t le_cd;
        uint8_t le_pad[2];
        uint64_t le_hash;
    } l_entry;
    struct zap_leaf_array {
        uint8_t la_type;
        uint8_t la_array[ZAP_LEAF_ARRAY_BYTES];
        uint16_t la_next;
    } l_array;
    struct zap_leaf_free {
        uint8_t lf_type;
        uint8_t lf_pad[ZAP_LEAF_ARRAY_BYTES];
        uint16_t lf_next;
    } l_free;
} l_chunk[ZAP_LEAF_NUMCHUNKS];
} zap_leaf_phys_t;

```

Header

The header for the ZAP leaf is stored in a `zap_leaf_header` structure. Its description is as follows:

lhr_block_type: always ZBT_LEAF (see Table 14 for values)

lhr_next: 64 bit integer block id for the next leaf in a block chain.

lhr_prefix and lhr_prefix_len: Each leaf (or chain of leaves) stores the ZAP entries whose first `lhr_prefixlen` bits of their hash value equals `lhr_prefix`. `lhr_prefixlen` can be equal to or less than `zt_shift` (the number of bits used to index into the pointer table) in which case multiple pointer table buckets reference the same leaf.

lhr_magic: leaf magic number == *0x2ABIEAF* (zap-leaf)

lhr_nfree: number of free chunks in this leaf (chunks described below)

lhr_nentries: number of ZAP entries stored in this leaf

lhr_freelist: head of a list of free chunks, 16 bit integer used to index into the `zap_leaf_chunk` array

Leaf Hash

The next 8KB of the `zap_leaf_phys_t` is the zap leaf hash table. The entries in the hash table reference chunks of type `zap_leaf_entry`. Twelve bits (the twelve following the `lhr_prefix_len` used to uniquely identify this block) of the attribute's hash value are used to index into this table. Hash table collisions are handled by chaining entries. Each bucket in the table contains a 16 bit integer which is the index into the `zap_leaf_chunk` array.

Section 5.2.4 : `zap_leaf_chunk`

Each leaf contains an array of chunks. There are three types of chunks: `zap_leaf_entry`, `zap_leaf_array`, and `zap_leaf_free`. Each attribute is represented by some number of these chunks: one `zap_leaf_entry` and some number of `zap_leaf_array` chunks. The illustration below shows how these chunks are arranged. A detailed description of each chunk type follows the illustration.

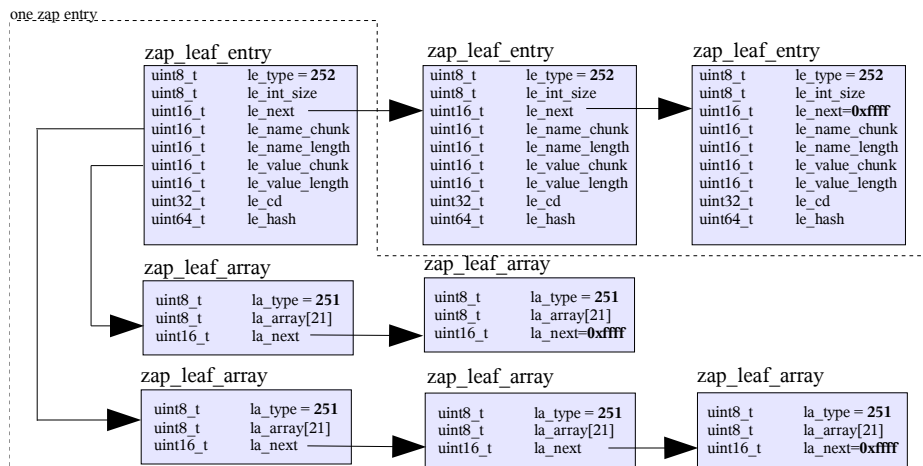

Illustration 18 zap leaf structure

zap_leaf_entry: The leaf hash table (described above) points to chunks of this type. This entry contains pointers to chunks of type `zap_leaf_array` which hold the name and value for the attributes being stored here.

le_type: `ZAP_LEAF_ENTRY == 252`

le_int_size: Size of integers in bytes for this entry.

le_next: Next entry in the `zap_leaf_chunk` chain. Chains occur when there are collisions in the hash table. The end of the chain is designated by a `le_next` value of `0xffff`.

le_name_chunk: 16 bit integer identifying the chunk of type

zap_leaf_array which contains the first 21 characters of this attribute's name.

le_name_length: The length of the attribute's name, including the NULL character.

le_value_chunk: 16 bit integer identifying the first chunk (type `zap_leaf_array`) containing the first 21 bytes of the attribute's value.

le_value_length: The length, in integer increments (*le_int_size*)

le_cd: The collision differentiator (“CD”) is a value associated with an entry whose hash value is the same as another entry within this ZAP object. When an entry is inserted into the ZAP object, the lowest CD which is not already used by an entry with the same hash value is assigned. In the absence of hash collisions, the CD value will be zero.

le_hash: 64 bit hash of this attribute's name.

zap_leaf_array: Chunks of the `zap_leaf_array` hold either the name or the value of the ZAP attribute. These chunks can be strung together to provide for long names or large values. `zap_leaf_array` chunks are pointed to by a `zap_leaf_entry` chunk.

la_type: `ZAP_LEAF_ARRAY == 251`

la_array: 21 byte array containing the name or value's value. Values of type “integer” are always stored in big endian format, regardless of the machine's native endianness.

la_next: 16 bit integer used to index into the `zap_leaf_chunk` array and references the next `zap_leaf_array` chunk for this attribute; a value of `0xffff` (`CHAIN_END`) is used to designate the end of the chain

zap_leaf_free: Unused chunks are kept in a chained free list. The root of the free list is stored in the leaf header.

lf_type: `ZAP_LEAF_FREE == 253`

lf_next: 16 bit integer pointing to the next free chunk.

Chapter Six – ZPL

The ZPL, ZFS POSIX Layer, makes DMU objects look like a POSIX filesystem. POSIX is a standard defining the set of services a filesystem must provide. ZFS filesystems provide all of these required services.

The ZPL represents filesystems as an object set of type `DMU_OST_ZFS`. All snapshots, clones and filesystems are implemented as an object set of this type. The ZPL uses a well defined format for organizing objects in its object set. The section below describes this layout.

Section 6.1: ZPL Filesystem Layout

A ZPL object set has one object with a fixed location and fixed object number. This object is called the “master node” and always has an object number of 1. The master node is a ZAP object containing three attributes: `DELETE_QUEUE`, `VERSION`, and `ROOT`.

Name: `DELETE_QUEUE`

Value: 64 bit object number for the delete queue object

Description: The delete queue provides a list of deletes that were in-progress when the filesystem was force unmounted or as a result of a system failure such as a power outage. Upon the next mount of the filesystem, the delete queue is processed to remove the files/dirs that are in the delete queue. This mechanism is used to avoid leaking files and directories in the filesystem.

Name: `VERSION`

Value: Currently a value of “1”.

Description: ZPL version used to lay out this filesystem.

Name: `ROOT`

Value: 64 bit object number

Description: This attribute's value contains the object number for the top level directory in this filesystem, the root directory.

Section 6.2: Directories and Directory Traversal

Filesystem directories are implemented as ZAP objects (object type `DMU_OT_DIRECTORY`). Each directory holds a set of name-value pairs which contain the names and object numbers for each directory entry. Traversing through a directory tree is as simple as looking up the value for an entry and reading that object number.

All filesystem objects contain a `znode_phys_t` structure in the bonus buffer of it's dnode. This structure stores the attributes for the filesystem object. The `znode_phys_t` structure is shown below.

```

typedef struct znode_phys {
    uint64_t zp_atime[2];
    uint64_t zp_mtime[2];
    uint64_t zp_ctime[2];
    uint64_t zp_crtime[2];
    uint64_t zp_gen;
    uint64_t zp_mode;
    uint64_t zp_size;
    uint64_t zp_parent;
    uint64_t zp_links;
    uint64_t zp_xattr;
    uint64_t zp_rdev;
    uint64_t zp_flags;
    uint64_t zp_uid;
    uint64_t zp_gid;
    uint64_t zp_pad[4];
    zfs_znode_acl_t zp_acl;
} znode_phys_t

```

zp_atime: Two 64 bit integers containing the last file access time in seconds (zp_atime[0]) and nanoseconds (zp_atime[1]) since January 1st 1970 (GMT).

zp_mtime: Two 64 bit integers containing the last file modification time in seconds (zp_mtime[0]) and nanoseconds (zp_mtime[1]) since January 1st 1970 (GMT).

zp_ctime: Two 64 bit integers containing the last file change time in seconds (zp_ctime[0]) and nanoseconds (zp_ctime[1]) since January 1st 1970 (GMT).

zp_crtime: Two 64 bit integers containing the file's creation time in seconds (zp_crtime[0]) and nanoseconds (zp_crtime[1]) since January 1st 1970 (GMT).

zp_gen: 64 bit generation number, contains the transaction group number of the creation of this file.

zp_mode: 64 bit integer containing file mode bits and file type. The lower 8 bits of the mode contain the access mode bits, for example 755. The 9th bit is the sticky bit and can be a value of zero or one. Bits 13-16 are used to designate the file type. The file types can be seen in the table below.

<i>Type</i>	<i>Description</i>	<i>Value in bits 13-16</i>
S_IFIFO	Fifo	0x1
S_IFCHR	Character Special Device	0x2
S_IFDIR	Directory	0x4
S_IFBLK	Block special device	0x6
S_IFREG	Regular file	0x8
S_IFLNK	Symbolic Link	0xA
S_IFSOCK	Socket	0xC
S_IFDOOR	Door	0xD
S_IFPORT	Event Port	0xE

Table 15 File Types and their associated mode bits

zp_size: size of file in bytes

zp_parent: object id of the parent directory containing this file

zp_links: number of hard links to this file

zp_xattr: object ID of a ZAP object which is the hidden attribute directory. It is treated like a normal directory in ZFS, except that its hidden and an application will need to "tunnel" into the file via `openat()` to get to it.

zp_rdev: `dev_t` for files of type `S_IFCHR` or `S_IFBLK`

zp_flags: Persistent flags set on the file. The following are valid flag values.

<i>Flag</i>	<i>Value</i>
ZFS_XATTR	0x1
ZFS_INHERIT_ACE	0x2

Table 16 zp_flag values

zp_uid: 64 bit integer (`uid_t`) of the files owner.

zp_gid: 64 bit integer (`gid_t`) owning group of the file.

zp_acl: `zfs_znode_acl` structure containing any ACL entries set on this file. The `zfs_znode_acl` structure is defined below.

Section 6.3: ZFS Access Control Lists

Access control lists (ACL) serve as a mechanism to allow or restrict user access privileges on a ZFS object. ACLs are implemented in ZFS as a table containing ACEs (Access Control Entries).

The `znode_phys_t` contains a `zfs_znode_acl` structure. This structure is shown below.

```
#define ACE_SLOT_CNT      6

typedef struct zfs_znode_acl {
    uint64_t    z_acl_extern_obj;
```

```

uint32_t    z_acl_count;
uint16_t    z_acl_version;
uint16_t    z_acl_pad;
ace_t       z_ace_data[ACE_SLOT_CNT];
} zfs_znode_acl_t;

```

z_acl_extern_obj: Used for holding ACLs that won't fit in the znode. In other words, its for ACLs great than 6 ACEs. The object type of an extern ACL is DMU_OT_ACL.

z_acl_count: number of ACE entries that make up an ACL

z_acl_version: reserved for future use.

z_acl_pad: reserved for future use.

z_ace_data: Array of up to 6 ACEs.

An ACE specifies an access right to an individual user or group for a specific object.

```

typedef struct ace {
    uid_t      a_who;
    uint32_t   a_access_mask;
    uint16_t   a_flags;
    uint16_t   a_type;
} ace_t;

```

a_who: This field is only meaningful when the ACE_OWNER, ACE_GROUP and ACE_EVERYONE flags (set in *a_flags*, described below) are not asserted. The *a_who* field contains a UID or GID. If the ACE_IDENTIFIER_GROUP flag is set in *a_flags* (see below), the *a_who* field will contain a GID. Otherwise, this field will contain a UID.

a_access_mask: 32 bit access mask. The table below shows the access attribute associated with each bit.

<i>Attribute</i>	<i>Value</i>
ACE_READ_DATA	0x00000001
ACE_LIST_DIRECTORY	0x00000001
ACE_WRITE_DATA	0x00000002
ACE_ADD_FILE	0x00000002
ACE_APPEND_DATA	0x00000004
ACE_ADD_SUBDIRECTORY	0x00000004
ACE_READ_NAMED_ATTRS	0x00000008
ACE_WRITE_NAMED_ATTRS	0x00000010
ACE_EXECUTE	0x00000020
ACE_DELETE_CHILD	0x00000040
ACE_READ_ATTRIBUTES	0x00000080
ACE_WRITE_ATTRIBUTES	0x00000100
ACE_DELETE	0x00010000
ACE_READ_ACL	0x00020000
ACE_WRITE_ACL	0x00040000
ACE_WRITE_OWNER	0x00080000
ACE_SYNCHRONIZE	0x00100000

Table 17 Access Mask Values

a_flags: 16 bit integer whose value describes the ACL entry type and inheritance flags.

<i>ACE flag</i>	<i>Value</i>
ACE_FILE_INHERIT_ACE	0x0001
ACE_DIRECTORY_INHERIT_ACE	0x0002
ACE_NO_PROPAGATE_INHERIT_ACE	0x0004
ACE_INHERIT_ONLY_ACE	0x0008
ACE_SUCCESSFUL_ACCESS_ACE_FLAG	0x0010
ACE_FAILED_ACCESS_ACE_FLAG	0x0020
ACE_IDENTIFIER_GROUP	0x0040
ACE_OWNER	0x1000
ACE_GROUP	0x2000
ACE_EVERYONE	0x4000

Table 18 Entry Type and Inheritance Flag Value

a_type: The type of this ace. The following types are listed in the table below.

<i>Type</i>	<i>Value</i>	<i>Description</i>
ACE_ACCESS_ALLOWED_ACE_TYPE	0x0000	Grants access as described in a_access_mask.
ACE_ACCESS_DENIED_ACE_TYPE	0x0001	Denies access as described in a_access_mask.
ACE_SYSTEM_AUDIT_ACE_TYPE	0x0002	Audit the successful or failed accesses (depending on the presence of the successful/failed access flags) as defined in the a_access_mask. ⁶
ACE_SYSTEM_ALARM_ACE_TYPE	0x0003	Alarm the successful of failed accesses as defined in the a_access_mask. ⁷

Table 19 ACE Types and Values

⁶ The action taken as an effect of triggering an audit is currently undefined in Solaris.

⁷ The action taken as an effect of triggering an alarm is currently undefined in Solaris.

Chapter Seven – ZFS Intent Log

The ZFS intent log (ZIL) saves transaction records of system calls that change the file system in memory with enough information to be able to replay them. These are stored in memory until either the DMU transaction group (txg) commits them to the stable pool and they can be discarded, or they are flushed to the stable log (also in the pool) due to a fsync, O_DSYNC or other synchronous requirement. In the event of a panic or power failure, the log records (transactions) are replayed.

There is one ZIL per file system. Its on-disk (pool) format consists of 3 parts:

- ZIL header
- ZIL blocks
- ZIL records

A log record holds a system call transaction. Log blocks can hold many log records and the blocks are chained together. Each ZIL block contains a block pointer in the trailer (blkptr_t) to the next ZIL block in the chain. Log blocks can be different sizes. The ZIL header points to the first block in the chain. Note there is not a fixed place in the pool to hold blocks. They are dynamically allocated and freed as needed from the blocks available. The illustration below shows the ZIL structure showing log blocks and log records of different sizes:

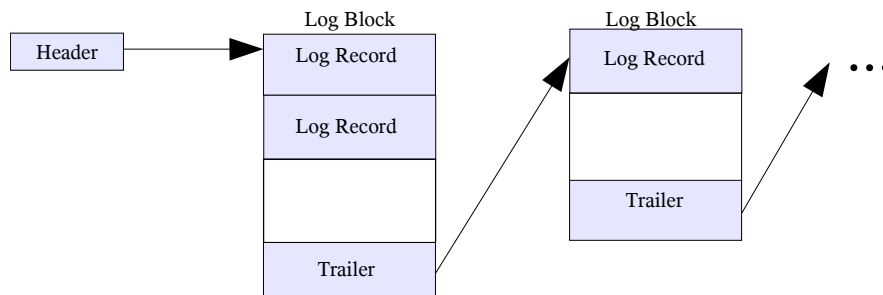

Illustration 19 Overview of ZIL Structure

More details of the current ZIL on disk structures are given below.

Section 7.1: ZIL header

There is one of these per ZIL and it has a simple structure:

```
typedef struct zil_header {
    uint64_t zh_claim_txg; /* txg in which log blocks were claimed */
    uint64_t zh_replay_seq; /* highest replayed sequence number */
    blkptr_t zh_log; /* log chain */
} zil_header_t;
```

Section 7.2: ZIL blocks

ZIL blocks contain ZIL records. The blocks are allocated on demand and are of a variable size according to need. The size field is part of the `blkptr_t` which points to a log block. Each block is filled with records and contains a `zil_trailer_t` at the end of the block:

ZIL Trailer

```
typedef struct zil_trailer {
    blkptr_t      zit_next_blk;    /* next block in chain */
    uint64_t zit_nused;           /* bytes in log block used */
    zio_block_tail_t zit_bt;      /* block trailer */
} zil_trailer_t;
```

ZIL records

ZIL record common structure

ZIL records all start with a common section followed by a record (transaction) specific structure. The common log record structure and record types (values for `lrc_txtype`) are:

```
typedef struct {
    uint64_t lrc_txtype;           /* common log record header */
    uint64_t lrc_reclen;          /* intent log transaction type */
    uint64_t lrc_txg;             /* transaction record length */
    uint64_t lrc_seq;             /* dmuf transaction group number */
} lr_t;                           /* intent log sequence number */

#define TX_CREATE      1          /* Create file */
#define TX_MKDIR       2          /* Make directory */
#define TX_MKXATTR     3          /* Make XATTR directory */
#define TX_SYMLINK     4          /* Create symbolic link to a file */
#define TX_REMOVE     5          /* Remove file */
#define TX_RMDIR      6          /* Remove directory */
#define TX_LINK       7          /* Create hard link to a file */
#define TX_RENAME     8          /* Rename a file */
#define TX_WRITE      9          /* File write */
#define TX_TRUNCATE  10          /* Truncate a file */
#define TX_SETATTR   11          /* Set file attributes */
#define TX_ACL       12          /* Set acl */
```

ZIL record specific structures

For each of the record (transaction) types listed above there is a specific structure which embeds the common structure. Within each record enough information is saved in order to be able to replay the transaction (usually one VOP call). The VOP layer will pass in-memory pointers to vnodes. These have to be converted to stable pool object identifiers (oids). When replaying the transaction the VOP layer is called again. To do this we reopen the object and pass it's vnode. Some of the record specific structures are used for more than one transaction type. The `lr_create_t` record specific structure is used for: `TX_CREATE`, `TX_MKDIR`, `TX_MKXATTR` and `TX_SYMLINK`, and `lr_remove_t` is used for both

TX_REMOVE and TX_RMDIR. All fields (other than strings and user data) are 64 bits wide. This provides for a well defined alignment which allows for easy compatibility between different architectures, and easy endianness conversion if necessary. Here's the definition of the record specific structures:

```
typedef struct {
    lr_t          lr_common;    /* common portion of log record */
    uint64_t     lr_doid;      /* object id of directory */
    uint64_t     lr_foid;      /* object id of created file object */
    uint64_t     lr_mode;      /* mode of object */
    uint64_t     lr_uid;       /* uid of object */
    uint64_t     lr_gid;       /* gid of object */
    uint64_t     lr_gen;       /* generation (txg of creation) */
    uint64_t     lr_ctime[2];   /* creation time */
    uint64_t     lr_rdev;      /* rdev of object to create */
    /* name of object to create follows this */
    /* for symlinks, link content follows name */
} lr_create_t;

typedef struct {
    lr_t          lr_common;    /* common portion of log record */
    uint64_t     lr_doid;      /* obj id of directory */
    /* name of object to remove follows this */
} lr_remove_t;

typedef struct {
    lr_t          lr_common;    /* common portion of log record */
    uint64_t     lr_doid;      /* obj id of directory */
    uint64_t     lr_link_obj;  /* obj id of link */
    /* name of object to link follows this */
} lr_link_t;

typedef struct {
    lr_t          lr_common;    /* common portion of log record */
    uint64_t     lr_sdoid;     /* obj id of source directory */
    uint64_t     lr_tdoid;     /* obj id of target directory */
    /* 2 strings: names of source and destination follow this */
} lr_rename_t;

typedef struct {
    lr_t          lr_common;    /* common portion of log record */
    uint64_t     lr_foid;      /* file object to write */
    uint64_t     lr_offset;    /* offset to write to */
    uint64_t     lr_length;    /* user data length to write */
    uint64_t     lr_blkoff;    /* offset represented by lr_blkptr */
    blkptr_t     lr_blkptr;    /* spa block pointer for replay */
    /* write data will follow for small writes */
} lr_write_t;

typedef struct {
    lr_t          lr_common;    /* common portion of log record */
    uint64_t     lr_foid;      /* object id of file to truncate */
    uint64_t     lr_offset;    /* offset to truncate from */
    uint64_t     lr_length;    /* length to truncate */
}
```

```

} lr_truncate_t;

typedef struct {
    lr_t          lr_common;      /* common portion of log record */
    uint64_t      lr_foid;        /* file object to change attributes */
    uint64_t      lr_mask;        /* mask of attributes to set */
    uint64_t      lr_mode;        /* mode to set */
    uint64_t      lr_uid;         /* uid to set */
    uint64_t      lr_gid;         /* gid to set */
    uint64_t      lr_size;        /* size to set */
    uint64_t      lr_atime[2];    /* access time */
    uint64_t      lr_mtime[2];    /* modification time */
} lr_setattr_t;

typedef struct {
    lr_t          lr_common;      /* common portion of log record */
    uint64_t      lr_foid;        /* obj id of file */
    uint64_t      lr_aclcnt;      /* number of acl entries */
    /* lr_aclcnt number of ace_t entries follow this */
} lr_acl_t;

```

Chapter Eight – ZVOL (ZFS volume)

ZVOL (ZFS Volumes) provides a mechanism for creating logical volumes. ZFS volumes are exported as block devices and can be used like any other block device. ZVOLs are represented in ZFS as an object set of type DMU_OT_ZVOL (see Table 11). A ZVOL object set has a very simple format consisting of two objects: a properties object and a data object, object type DMU_OT_ZVOL_PROP and DMU_OT_ZVOL respectively. Both objects have statically assigned object Ids. Each object is described below.

ZVOL Properties Object

Type: DMU_OT_ZVOL_PROP

Object #: 2

Description: The ZVOL property object is a ZAP object containing attributes associated with this volume. A particular attribute of interest is the “*volsize*” attribute. This attribute contains the size, in bytes, of the volume.

ZVOL Data

Type: DMU_OT_ZVOL

Object #: 1

Description: This object stores the contents of this virtual block device.