



Hard disk drive specifications

Ultrastar 36LZX

3.5 inch SCSI hard disk drive



Models: DDYS-T36950
DDYS-T18350
DDYS-T09170

1st Edition (Rev. 1.0) S31L-8989-00 (December 8th, 1999)
2nd Edition (Rev. 1.1) S31L-8989-01 (January 21st, 2000)
3rd Edition (Rev. 1.2) S31L-8989-02 (March 6th, 2000)
4th Edition (Rev. 1.3) S31L-8989-03 (March 15th, 2000)
5th Edition (Rev. 2.0) S31L-8989-04 (March 27th, 2000)
6th Edition (Rev. 2.1) S31L-8989-05 (June 9th, 2000)

The following paragraph does not apply to the United Kingdom or any country where such provisions are inconsistent with local law: INTERNATIONAL BUSINESS MACHINES CORPORATION PROVIDES THIS PUBLICATION “AS IS” WITHOUT WARRANTY OF ANY KIND, EITHER EXPRESS OR IMPLIED, INCLUDING, BUT NOT LIMITED TO, THE IMPLIED WARRANTIES OF MERCHANTABILITY OR FITNESS FOR A PARTICULAR PURPOSE. Some states do not allow disclaimer or express or implied warranties in certain transactions, therefore, this statement may not apply to you.

This publication could include technical inaccuracies or typographical errors. Changes are periodically made to the information herein; these changes will be incorporated in new editions of the publication. IBM may make improvements and/or changes in the product(s) and/or the program(s) described in this publication at any time.

It is possible that this publication may contain reference to, or information about, IBM products (machines and programs), programming, or services that are not announced in your country. Such references or information must not be construed to mean that IBM intends to announce such IBM products, programming, or services in your country.

Technical information about this product is available by contacting your local IBM representative or the following:

Internet: <http://www.ibm.com/harddrive>

IBM may have patents or pending patent applications covering subject matter in this document. The furnishing of this document does not give you any license to these patents. You can send license inquiries, in writing, to the IBM Director of Commercial Relations, IBM Corporation, Armonk, NY 10577.

©Copyright International Business Machines Corporation 1999, 2000. All rights reserved.
Note to U.S. Government Users —Documentation related to restricted rights —Use, duplication or disclosure is subject to restrictions set forth in GSA ADP Schedule Contract with IBM Corp.

Table of contents

1.0 General	9
1.1 Introduction	9
1.2 Glossary	10
1.3 General caution	10
2.0 Outline of the drive	11
3.0 Fixed disk subsystem description	13
3.1 Control electronics	13
3.2 Head disk assembly	13
3.3 Actuator	13
4.0 Drive characteristics	15
4.1 Formatted capacity	15
4.2 Data sheet	15
4.3 Inquiry Information	16
4.3.1 <i>Product ID</i>	16
4.3.2 <i>World Wide ID - Block assignment</i>	16
4.4 Cylinder allocation	17
4.5 Performance characteristics	18
4.5.1 <i>Command overhead</i>	18
4.5.2 <i>Mechanical positioning</i>	19
4.5.3 <i>Drive ready time</i>	20
4.5.4 <i>Spindle stop time</i>	20
4.5.5 <i>Data transfer speed</i>	21
4.5.6 <i>Buffering operation (read ahead/write cache)</i>	21
4.5.7 <i>Throughput</i>	22
5.0 Data integrity	23
5.1 Equipment status	23
5.2 Error recovery procedure	23
6.0 Physical format	25
6.1 Shipped format (P-List)	25
6.2 Reassigned format (G-List)	25
7.0 Specification	27
7.1 Electrical interface specification	27
7.1.1 <i>Power connector</i>	27
7.1.2 <i>SCSI bus connector</i>	28
7.1.3 <i>SCSI cable</i>	31
7.1.4 <i>SCSI bus terminator</i>	31
7.1.5 <i>Hot plug/unplug</i>	31
7.1.6 <i>SCSI bus electrical characteristics</i>	31
7.1.7 <i>Auxiliary connector on 68 pin model</i>	32
7.2 Option jumper block	33
7.2.1 <i>Jumper signal description on J6</i>	34
7.2.2 <i>Jumper signal description on J-4</i>	36
7.3 Environment	38
7.3.1 <i>Corrosion test</i>	38
7.4 Cooling requirements	39
7.5 DC power requirements	40
7.5.1 <i>Input voltage</i>	40
7.5.2 <i>Power supply current</i>	40
7.5.3 <i>Ripple voltage</i>	41
7.5.4 <i>Power consumption efficiency index</i>	41

7.6	Reliability	42
7.6.1	Start/stop cycles	42
7.6.2	Data reliability	42
7.6.3	Seek/ID miscompare errors	42
7.6.4	Equipment errors	42
7.6.5	Failure prediction (PFA/S.M.A.R.T.)	42
7.6.6	Preventive maintenance	42
7.6.7	Temperature Warning	43
7.7	Mechanical specifications	44
7.7.1	Outline	44
7.7.2	Mechanical dimensions	45
7.7.3	Interface connector	46
7.7.4	Mounting positions and tappings	47
7.7.5	Heads unload and actuator lock	48
7.7.6	Breather hole	48
7.8	Vibration and shock	49
7.8.1	Operating vibration	49
7.8.2	Non-operating vibrations	50
7.8.3	Operating shock	50
7.8.4	Non-operating shock	51
7.9	Acoustics	52
7.9.1	Sound power levels	52
7.10	Identification labels	53
7.11	Electromagnetic compatibility	54
7.11.1	CE Mark	54
7.11.2	C-Tick Mark	54
7.12	Safety	55
7.12.1	UL and CSA standard conformity	55
7.12.2	IEC Compliance	55
7.12.3	German Safety Mark	55
7.12.4	Flammability	55
8.0	SCSI Command Set	57
8.1	SCSI Control Byte	58
8.2	Abbreviations	58
8.3	Byte ordering conventions	58
8.4	FORMAT UNIT (04)	59
8.4.1	Defect list	60
8.4.2	Defect descriptor	61
8.5	INQUIRY (12)	64
8.5.1	INQUIRY DATA	66
8.6	LOG SELECT (4C)	74
8.7	LOG SENSE (4D)	75
8.7.1	Log Page parameters	76
8.7.2	Log Sense Page 0	77
8.7.3	Log Sense Page 2	78
8.7.4	Log Sense Page 3	80
8.7.5	Log Sense Page 5	82
8.7.6	Log Sense Page 6	84
8.7.7	Log Sense Page D	85
8.7.8	Log Sense Page E	86
8.7.9	Log Sense Page F	87
8.7.10	Log Sense Page 10	88
8.7.11	Log Sense Page 2F	91
8.8	MODE SENSE (1A)	92
8.8.1	Mode Parameter List	93

8.8.2	Mode Page 0 (Vendor Unique Parameters)	97
8.8.3	Mode Page 1 (Read/Write Error Recovery Parameters)	100
8.8.4	Mode Page 2 (Disconnect/Reconnect Parameters)	105
8.8.5	Mode Page 3 (Format Device Parameters)	107
8.8.6	Mode Page 4 (Rigid Disk Drive Geometry Parameters)	109
8.8.7	Mode Page 7 (Verify Error Recovery Parameters)	110
8.8.8	Mode Page 8 (Caching Parameters)	112
8.8.9	Mode Page A (Control Mode Page Parameters)	115
8.8.10	Mode Page 0C (Notch Parameters)	117
8.8.11	Mode Page 19 (Port Control)	119
8.8.12	Mode Page 1A (Power Control)	120
8.8.13	Mode Page 1C (Informational Exceptions Control)	121
8.9	MODE SENSE (5A)	123
8.10	MODE SELECT (15)	124
8.11	MODE SELECT (55)	126
8.12	PERSISTENT RESERVE IN (5E)	127
8.12.1	Service Action	127
8.12.2	Parameter data for Read Keys	128
8.12.3	Parameter data for Read Reservations	128
8.13	PERSISTENT RESERVE OUT (5F)	130
8.13.1	Service Action	131
8.13.2	Scope	134
8.13.3	Type	134
8.13.4	Parameter list	136
8.13.5	Summary	136
8.14	PRE-FETCH (34)	138
8.15	READ (08)	139
8.16	READ BUFFER (3C)	140
8.16.1	Combined Header And Data (Mode 0000b)	141
8.16.2	Read Data (Mode 0010b)	141
8.16.3	Descriptor (Mode 0011b)	141
8.16.4	Read Data from Echo Buffer (Mode 1010b)	142
8.16.5	Echo Buffer Descriptor (Mode 1011b)	142
8.17	READ CAPACITY (25)	143
8.18	READ DEFECT DATA (37)	145
8.18.1	Defect List Header	146
8.18.2	Bytes from Index Format (100b)	146
8.18.3	Physical Sector Format (101b)	147
8.19	READ DEFECT DATA (B7)	148
8.19.1	Defect List Header	149
8.19.2	Bytes from Index Format (100b)	149
8.19.3	Physical Sector Format (101b)	150
8.20	READ EXTENDED (28)	151
8.21	READ LONG (3E)	152
8.22	REASSIGN BLOCKS (07)	153
8.23	RECEIVE DIAGNOSTICS (1C)	155
8.23.1	Receive Diagnostic Page 0	155
8.23.2	Receive Diagnostic Page 40	156
8.23.3	Receive Diagnostic Page 80	157
8.24	RELEASE (17)	158
8.25	RELEASE (57)	159
8.26	REPORT DEVICE IDENTIFIER (A3)	160
8.27	REPORT LUN (A0)	162
8.28	REQUEST SENSE (03)	163
8.29	RESERVE (16)	164

8.30	RESERVE (56)	165
8.31	REZERO UNIT (01)	166
8.32	SEEK (0B)	167
8.33	SEEK EXTENDED (2B)	168
8.34	SEND DIAGNOSTIC (1D)	169
	8.34.1 <i>Send Diagnostic Page 0</i>	171
	8.34.2 <i>Send Diagnostic Page 40</i>	171
	8.34.3 <i>Send Diagnostic Page 80</i>	172
8.35	SET DEVICE IDENTIFIER (A4)	173
8.36	START/STOP Unit (1B)	175
8.37	SYNCHRONIZE CACHE (35)	176
8.38	TEST UNIT READY (00)	177
8.39	VERIFY (2F)	178
8.40	WRITE (0A)	179
8.41	WRITE AND VERIFY (2E)	180
8.42	WRITE BUFFER (3B)	181
	8.42.1 <i>Combined Header And Data (Mode 0000b)</i>	182
	8.42.2 <i>Write Data (Mode 0010b)</i>	182
	8.42.3 <i>Download Microcode (Mode 0100b)</i>	183
	8.42.4 <i>Download Microcode and Save (Mode 0101b)</i>	183
	8.42.5 <i>Write Data to Echo Buffer (Mode 1010b)</i>	184
8.43	WRITE EXTENDED (2A)	185
8.44	WRITE LONG (3F)	186
8.45	WRITE SAME (41)	187
9.0	SCSI Status Byte	189
10.0	SCSI Message System	191
10.1	Supported Messages	191
	10.1.1 <i>COMMAND COMPLETE (00)</i>	192
	10.1.2 <i>SYNCHRONOUS DATA TRANSFER REQUEST (01,03,01H)</i>	192
	10.1.3 <i>WIDE DATA TRANSFER REQUEST (01,02,03H)</i>	197
	10.1.4 <i>PARALLEL PROTOCOL REQUEST (01,06,04H)</i>	199
	10.1.5 <i>SAVE DATA POINTER (02)</i>	200
	10.1.6 <i>RESTORE POINTERS (03)</i>	200
	10.1.7 <i>DISCONNECT (04)</i>	200
	10.1.8 <i>INITIATOR DETECTED ERROR (05)</i>	200
	10.1.9 <i>ABORT (06)</i>	201
	10.1.10 <i>MESSAGE REJECT (07)</i>	201
	10.1.11 <i>NO OPERATION (08)</i>	201
	10.1.12 <i>MESSAGE PARITY ERROR (09)</i>	201
	10.1.13 <i>LINKED COMMAND COMPLETE (0A)</i>	202
	10.1.14 <i>LINKED COMMAND COMPLETE WITH FLAG (0B)</i>	202
	10.1.15 <i>BUS DEVICE RESET (0C)</i>	202
	10.1.16 <i>ABORT TAG (0D)</i>	202
	10.1.17 <i>CLEAR QUEUE TAG (0E)</i>	202
	10.1.18 <i>QUEUE TAG MESSAGES (20h, 21h, 22h)</i>	203
	10.1.19 <i>IGNORE WIDE RESIDUE (23h)</i>	204
	10.1.20 <i>IDENTIFY (80 - FF)</i>	204
10.2	Supported Message Functions	205
10.3	Attention Condition	206
10.4	SCSI Bus Related Error Handling Protocol	207
	10.4.1 <i>Unexpected BUS FREE Phase Error Condition</i>	207
	10.4.2 <i>MESSAGE OUT Phase Parity Error</i>	207
	10.4.3 <i>MESSAGE IN Phase Parity Error (Message Parity Error)</i>	207
	10.4.4 <i>COMMAND Phase Parity Error</i>	207
	10.4.5 <i>DATA OUT Phase Parity Error</i>	207

10.4.6	INITIATOR DETECTED ERROR Message	208
10.4.7	MESSAGE REJECT Message	208
11.0	Additional information	209
11.1	SCSI Protocol	209
11.1.1	Priority of SCSI Status Byte Reporting	209
11.1.2	Invalid LUN in Identify Message	210
11.1.3	Incorrect Initiator Connection	210
11.1.4	Command Processing during execution of active I/O process	211
11.1.5	Unit Attention Condition	213
11.1.6	Command Processing During Startup and Format Operations	214
11.1.7	Internal Error Condition	214
11.1.8	Deferred Error	215
11.1.9	Degraded Mode	215
11.1.10	Command processing while reserved	221
11.2	Priority commands	222
11.3	Command queuing	222
11.3.1	Queue depth	223
11.3.2	Tagged queuing	223
11.3.3	Untagged queuing	223
11.3.4	Command queuing rule	223
11.3.5	Queue Full status	223
11.3.6	Device behavior on Command queuing	223
11.4	Command reordering	224
11.5	Concurrent I/O Process	224
11.6	Back to Back Write	224
11.7	Write Cache	225
11.8	Automatic Rewrite/Reallocate	225
11.9	Segmented Caching	227
11.9.1	Overview	227
11.9.2	Read Ahead	227
11.10	Reselection Timeout	227
11.11	Single Initiator Selection	227
11.12	Non-arbitrating systems	227
11.13	Selection without ATN	228
11.14	Multiple Initiator Environment	228
11.14.1	Initiator Sense Data	228
11.14.2	Initiator Mode Select/Mode Sense Parameters	228
11.14.3	Initiator Data Transfer Mode Parameter	228
11.15	Contingent Allegiance Condition	228
11.16	Reset	229
11.16.1	Reset Sources	229
11.16.2	Reset Actions	229
11.17	Diagnostics	230
11.17.1	Power on Diagnostics	230
11.17.2	Diagnostics Command	230
11.17.3	Diagnostics Fault Reporting	230
11.18	Idle Time Function	231
12.0	SCSI Sense Data	233
12.1	SCSI Sense Data Format	233
12.2	Sense Data Description	234
12.2.1	Valid (Bit 7 of byte 0)	234
12.2.2	Error Code (Bit 6 - 0 of byte 0)	234
12.2.3	ILL: Incorrect Length Indicator (Bit 5 of byte 2)	234
12.2.4	Sense Key (Bit 3 - 0 of byte 2)	234
12.2.5	Information Bytes (Byte 3 through 6)	235

12.2.6	<i>Additional Sense Length (Byte 7)</i>	235
12.2.7	<i>Command Specific Information (Byte 8 through 11)</i>	235
12.2.8	<i>Additional Sense Code/Qualifier (Byte 12 and 13)</i>	236
12.2.9	<i>FRU : Field Replaceable Unit (Byte 14)</i>	240
12.2.10	<i>Sense Key Specific (Byte 15 through 17)</i>	240
12.2.11	<i>Reserved (Byte 18 through 19)</i>	242
12.2.12	<i>Vendor unique error information (Byte 20 through 23)</i>	242
12.2.13	<i>Physical Error Record (Byte 24 thru 29)</i>	247
12.2.14	<i>Reserved (Byte 30 through 31)</i>	247

1.0 General

1.1 Introduction

This document describes the specifications of the following IBM 3.5 inch SCSI drives.

- DDYS-T36950
 - Ultra 160, 68 pin
 - Ultra 160, 80 pin
- DDYS-T18350
 - Ultra 160, 68 pin
 - Ultra 160, 80 pin
- DDYS-T09170
 - Ultra 160, 68 pin
 - Ultra 160, 80 pin

NOTE: The specifications in this document are subject to change without notice.

1.2 Glossary

Word	Meaning
Kbpi	1,000 Bits Per Inch
Mbps	1,000,000 Bits per second
GB	1,000,000,000 bytes
MB	1,000,000 bytes
KB	1,000 bytes unless otherwise specified
Mb/sq.in	1,000,000 bits per square inch
MLC	Machine Level Control
PFA	Predictive Failure Analysis (Trademark of IBM Corp.)
S.M.A.R.T.	Self-Monitoring Analysis and Reporting Technology
ADM	Automatic Drive Maintenance
SCAM	SCSI Configured Automatically
SE	Single Ended SCSI
LVD	Low Voltage Differential SCSI
FC-AL	Fibre Channel - Arbitrated Loop

1.3 General caution

This drive can be damaged by ESD (Electric Static Discharge). Any damages incurred to the drive after removing it from the shipping package and the ESD protective bag are the responsibility of the user.

2.0 Outline of the drive

- Data capacity 36.7/18.3/9.1 GB
- Ultra 160 (68/80 pin)
- Interleave factor 1:1
- Variable Sector Size (512-528 bytes/sector)
- Tagged Command Queuing support
- Automatic read/write data transfer
- 4MB segmented sector buffer (128KBx28, 256KBx14 or 512KBx7)
- 4.9 msec seek time in read operation
- Adaptive read ahead algorithm
- Write Cache
- Back to back write
- ECC on the fly
- Automatic defect reallocation
- Self diagnostics at power on
- Closed loop actuator servo
- High level of integration of the electronics
- Non head disk contact start stop
- 10000rpm spindle rotation
- Automatic actuator lock
- PFA (SMART)
- Glass substrate disks

NOTE: PFA (Predictive Failure Analysis) is a trademark of the IBM Corporation.

3.0 Fixed disk subsystem description

3.1 Control electronics

The drive is electronically controlled by a microprocessor, logic modules, digital/analogue modules, and various drivers and receivers. The control electronics perform the following major functions:

- Perform self-checkout (diagnostics).
- Conduct a power-up sequence and calibrate the servo.
- Monitor various timers for head settling, servo failure, etc.
- Analyze servo signals to provide closed loop control. These include position error signal and estimated velocity.
- Control the voice coil motor driver to align the actuator onto a desired position.
- Monitor the actuator position and determine the target track for a seek operation.
- Constantly monitor error conditions of the servo and take corresponding action if an error occurs.
- Control starting, stopping, and rotating speed of the spindle.
- Control and interpret all interface signals between the host controller and the drive.
- Control read write accessing of the disk media, including defect management and error recovery.

3.2 Head disk assembly

The head disk assembly (HDA) is assembled in a clean room environment and contains disks, a spindle motor, actuator assembly, and voice coil motor. Air is constantly circulated and filtered when the drive is operational. Venting of the HDA is accomplished via a breather filter.

The spindle is driven directly by a brushless, sensorless DC drive motor. Dynamic braking is used to stop the spindle quickly.

3.3 Actuator

The read/write heads are mounted in the actuator. The actuator is a swing-arm assembly driven by a voice coil motor. A closed-loop positioning servo controls the movement of the actuator. An embedded servo pattern supplies feedback to the positioning servo to keep the read/write heads centered over the desired track.

The actuator assembly is balanced to allow vertical or horizontal mounting without adjustment.

When the drive is powered off, the actuator automatically moves the head to a load/unload zone outside of the data area, where the actuator is locked.

4.0 Drive characteristics

4.1 Formatted capacity

Description	DDYS-T36950	DDYS-T18350	DDYS-T09170
Label capacity	36.70 GB	18.35 GB	9.17 GB
Sectors per track	512 - 528	512 - 528	512 - 528
Number of heads	12	6	3
Number of disks	6	3	2
Total data bytes (512 bytes/sector)	36,703,918,080	18,351,959,040	9,173,114,880
Total logical data blocks	71,687,340 (445DCACH)	35,843,670 (222EE56h)	17,916,240 (1116150h)

Figure 1. Formatted capacity

4.2 Data sheet

Buffer to/from media [Mbit/sec]	280 - 452 Mbps
Host to/from buffer (interface transfer rate) [Mbyte/sec]	80 (68/80 pin FAST 40 WIDE) 160 (68/80 pin Ultra 160)
Data buffer size	4096 KB (512 KB used by firmware)
Number of buffer segments	7 x 512 KB or 14 x 256 KB or 28 x 128 KB
Rotational speed [RPM]	10,000
Recording density [Kbpi]	303 (Average) 352 (Max)
Track density [TPI]	20,000 (Average)
Areal density [Mb/sq.in.]	7040 (Max)
Data zone	11

Figure 2. Data sheet

NOTE: KB = 1,024 bytes

4.3 Inquiry Information

4.3.1 Product ID

Product ID in Inquiry data format - CmdDt = 0 EVPD = 0 on Page 66 is as follows.

Product ID	Description
DDYS-T09170N	9.1 GB, 68 pin
DDYS-T09170M	9.1 GB, 80 pin
DDYS-T18350N	18.3 GB, 68 pin
DDYS-T18350M	18.3 GB, 80 pin
DDYS-T36950N	36.7 GB, 68 pin
DDYS-T36950M	36.7 GB, 80 pin

Figure 3. Product ID in Inquiry Command

4.3.2 World Wide ID - Block assignment

Block assignment of World Wide ID in Inquiry data format - EVPD = 1 - Page Code = 83h on Page 73 is as follows.

Manufacturing site	Product	Block assignment
Fujisawa, Japan	DDYS-T09170	005h
	DDYS-T18350	006h
	DDYS-T36950	007h
Saha Union, Thailand	DDYS-T09170	105h
	DDYS-T18350	106h
	DDYS-T36950	107h
SFV, Hungary	DDYS-T09170	205h
	DDYS-T18350	206h
	DDYS-T36950	207h
SPT, Thailand	DDYS-T09170	505h
	DDYS-T18350	506h
	DDYS-T36950	507h
Singapore	DDYS-T09170	705h
	DDYS-T18350	706h
	DDYS-T36950	707h

Figure 4. Block assignment of World Wide ID in Inquiry Command

4.4 Cylinder allocation

Zone	Physical Cylinders	Sectors/Track
Data Zone 0	0 - 378	504
Data Zone 1	379 - 2069	476
Data Zone 2	2070 - 3416	462
Data Zone 3	3417 - 6788	420
Data Zone 4	6789 - 7493	406
Data Zone 5	7494 - 8863	392
Data Zone 6	8864 - 10167	378
Data Zone 7	10168 - 11195	364
Data Zone 8	11196 - 11999	352
Data Zone 9	12000 - 13714	336
Data Zone 10	13715 - 15109	308

Figure 5. Cylinder allocation

NOTE: *Mode Page 3 (Format Device Parameters)* and *Mode Page 0C (Notch Parameters)* provide methods to determine medium format and zone parameters. See page 107 and page 117.

4.5 Performance characteristics

A drive's performance is characterized by the following parameters:

- Command overhead
- Mechanical head positioning
 - Seek time
 - Latency
- Data transfer speed
- Buffering operation (read ahead/write cache)

NOTE: All the above parameters contribute to drive performance. There are other parameters that contribute to the performance of the actual system. This specification tries to define the bare drive characteristics, not the system throughput, which depends on the system and the application.

4.5.1 Command overhead

Command overhead is defined as the time required:

- from last byte of command phase
- to the first byte of data phase
- excluding
 - Physical seek time
 - Latency time
 - Initiator delay with reconnections

Read Command Case (Drive is in quiescence state)	Time
Cache Not Hit	<400 usec
Cache Hit	<30 usec

Figure 6. Command overhead

4.5.2 Mechanical positioning

4.5.2.1 Average seek time (including settling)

Command Type	Typical	Max
Read	4.9 [msec]	5.9 [msec]
Write	5.9 [msec]	6.9 [msec]

Figure 7. Mechanical positioning performance

“Typical” and “Max” are given throughout the performance specification by:

Typical Average of the drive population tested at nominal environmental and voltage conditions.

Max Maximum value measured on any one drive over the full range of the environmental and voltage conditions. (See **Environment** on page 38 and **DC power requirements** on page 40 for ranges.)

The seek time is measured from the start of the actuator's motion to the start of a **reliable read or write operation**. “Reliable read or write” implies that error correction/recovery is not used to correct arrival problems. The average seek time is measured as the weighted average of all possible seek combinations.

$$\text{Weighted average} = \frac{\sum_{n=1}^{\text{max}} (\text{max}+1-n) (T_{n.in}+T_{n.out})}{(\text{max}+1) (\text{max})}$$

Where

max = Maximum seek length

n = Seek length (1 to max)

T_{n.in} = Inward measured seek time for an n track seek

T_{n.out} = Outward measured seek time for an n track seek

4.5.2.2 Full stroke seek time

Function	Typical	Maximum
Read	10.5 [msec]	11.5 [msec]
Write	11.5 [msec]	12.5 [msec]

Figure 8. Full stroke seek time

Full stroke seek is measured as the average of 1000 full stroke seeks with a **random head switch** from both directions (inward and outward).

4.5.2.3 Cylinder switch time (cylinder skew)

	Typical
Cylinder skew	1.6 [msec]

Figure 9. Cylinder Skew

A cylinder switch time is defined as the amount of time required by the fixed disk to access the next sequential block after reading the last sector in the current cylinder.

4.5.2.4 Head switch time (head skew)

	Typical
Head skew	1.1 [msec]

Figure 10. Head skew

A head switch time is defined as the amount of time required by the fixed disk to access the next sequential block after reading the last sector in the current track.

4.5.2.5 Average latency

Rotation	Time for a revolution	Average Latency
10,000 [RPM]	6.0 [msec]	3.0 [msec]

Figure 11. Latency time

4.5.3 Drive ready time

Model	Typical	Maximum
DDYS-T36950	18.0 [sec]	29.9 [sec]
DDYS-T18350	14.0 [sec]	29.9 [sec]
DDYS-T09170	14.0 [sec]	29.9 [sec]

Figure 12. Drive ready time

4.5.4 Spindle stop time

Model	Typical	Maximum
DDYS-T36950	20 [sec]	30 [sec]
DDYS-T18350	14 [sec]	30 [sec]
DDYS-T09170	14 [sec]	30 [sec]

Figure 13. Spindle stop time

The period from power off to complete stop of spindle is categorized as operating, and **Operating Shock criteria** are applied until complete stop of spindle. Refer to **Operating shock** on page 50.

4.5.5 Data transfer speed

Description	Typical
Disk-Buffer Transfer (Zone 0)	
Instantaneous	43.0 [Mbyte/sec]
Sustained	DDYS-T36950 36.1 [Mbyte/sec] DDYS-T18350 35.9 [Mbyte/sec] DDYS-T09170 35.5 [Mbyte/sec]
Disk-Buffer Transfer (Zone 11)	
Instantaneous	26.0 [Mbyte/sec]
Sustained	DDYS-T36950 22.1 [Mbyte/sec] DDYS-T18350 22.0 [Mbyte/sec] DDYS-T09170 21.7 [Mbyte/sec]
Buffer-Host	
68/80pin FAST40 Wide	80 [Mbyte/sec]
68/80pin Ultra 160	160 [Mbyte/sec]

Figure 14. Data transfer speed (sector size 512 bytes case)

- Instantaneous disk-buffer transfer rate is derived by
 $(\text{Number of sectors on a track}) \times 512 \times (\text{revolution/sec})$
NOTE: The number of sectors per track varies because of the linear density recording.
- Sustained disk-buffer transfer rate is defined by considering head/cylinder change time. This gives a local average data transfer rate. It is derived by
 $(\text{Sustained Transfer Rate}) = A / (B + C + D)$
 $A = (\text{Number of data sectors per cylinder}) \times 512$
 $B = ((\# \text{ of Surface per cylinder}) - 1) \times (\text{Head switch time})$
 $C = (\text{Cylinder change time})$
 $D = (\# \text{ of Surface}) \times (\text{One revolution time})$
- Buffer-host transfer rate defines the maximum data transfer rate on SCSI Bus. It also depends on the speed of the host.

4.5.6 Buffering operation (read ahead/write cache)

This hard disk drive has a buffer for read ahead and write caching. For details, refer to the SCSI interface specification.

Number of buffer segments: 7 x 512 KB or
 14 x 256 KB or
 28 x 128 KB

4.5.7 Throughput

4.5.7.1 Simple sequential access

Operation	Typical	Max
Sequential read/write	Zone 0 <480 [msec] Zone 11 <800 [msec]	Zone 0 <530 [msec] Zone 11 <880 [msec]

Figure 15. Simple sequential access performance (sector size 512 byte case)

The above table gives the time required to read/write for a total of 8000x consecutive blocks (16,777,216 bytes) accessed by 128 read/write commands. Typical and Max values are given by 100% and 110% of T respectively throughputs following performance description.

NOTE: Assumes a host system responds instantaneously.

$$T = A + B + C + 16,777,216/D$$

Where:

- T = Calculated Time
- A = Command Overhead (Cache No Hit)
- B = Average Seek Time
- C = Average Latency
- D = Sustained Disk-Buffer Transfer Rate

4.5.7.2 Random access

Operation	Typical	Maximum
Random read	34 [sec]	37 [sec]
Random write	38 [sec]	41 [sec]

Figure 16. Random access performance (sector size 512 bytes case)

The above table gives the time required to execute a total of 1000x read/write commands which access a random LBA.

$$T = (A + B + C) * 4096$$

Where:

- T = Calculated Time
- A = Command Overhead (Cache No Hit)
- B = Average Seek Time
- C = Average Latency

5.0 Data integrity

The drive retains recorded information under all non-write operations.

No more than one sector will be lost by power down during write operation while write cache is disabled. If power down occurs before completion of data transfer from write cache to disk while write cache is enabled, the data remaining in write cache will be lost. To prevent this data loss at power off, the following action is recommended:

- Confirm successful completion of SYNCHRONIZE CACHE (35h) command.

5.1 Equipment status

Equipment status is available to the host system any time the drive is not ready to read, write, or seek. This status normally exists at power-on time and will be maintained until the following conditions are satisfied:

- Access recalibration/tuning is complete.
- Spindle speed meets requirements for reliable operations.
- Self-check of drive is complete.

Appropriate error status is made available to the host system if any of the following condition occurs after the drive has become ready:

- Spindle speed goes outside of requirements for reliable operation.
- "Write fault" is detected.

5.2 Error recovery procedure

Errors occurring with the drive are handled by the error recovery procedure.

Errors that are uncorrectable after application of the error recovery procedures are reported to the host system as non-recoverable errors.

6.0 Physical format

Media defects are remapped to the next available sector during the Format Process in manufacturing. The mapping from LBA to the physical locations is calculated by an internally maintained table.

6.1 Shipped format (P-List)

- Data areas are optimally used.
- No extra sector is wasted as a spare throughout user data areas.
- All pushes generated by defects are absorbed by spare tracks of the inner zone.

Plist physical format

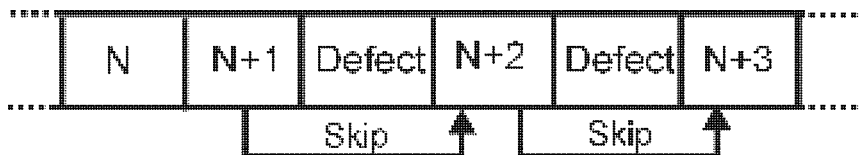

Figure 17. P-List physical format

NOTE: Defects are skipped without any constraint, such as track or cylinder boundary. The calculation from LBA to physical is done automatically by internal table.

6.2 Reassigned format (G-List)

- G-List is prepared for 3279 LBAs.
- Re-re-assign of the same LBA does not increase G-List entry.
- A cylinder for spare sectors is prepared every 256 physical cylinders.

NOTE: G-List entries are part of the normal maintenance work of hard disk drives. G-List entries are possible during early drive usage and are caused mainly by handling.

7.0 Specification

7.1 Electrical interface specification

7.1.1 Power connector

The power connector of 68 pin models complies with the ANSI SCSI"P" connector specifications. Power pin assignment of 68 pin models is as shown below.

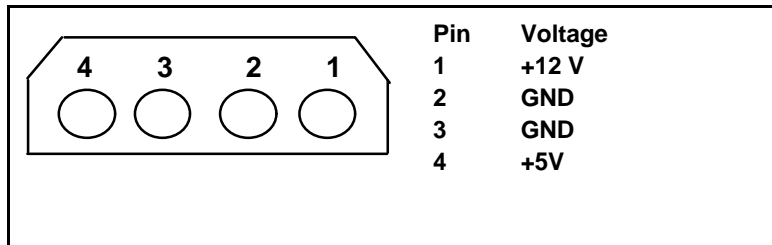

Figure 18. Power connector pin assignments

80 pin SCA-2 models use a DDK connector (PN HD2-PA080-A14B) or equivalent, which is compatible with the Specification of "Single Attachment for Small SCSI Disk Drives" SPI-3 document, Annex C.

Power pin assignment of the 80 pin (SCA-2) model is shown in **SCSI signal connector (80 pin SCA-2 model)** on page 29.

7.1.2 SCSI bus connector

DDYS-Txxxxx has 68 pin model and 80 pin SCA-2 model.

7.1.2.1 SCSI signal connector (68 pin model)

The pin assignments of interface signals conform to ANSI SPI-3 T10/1302D Revision 11 as follows:

Connector contact number	Signal name	Connector contact number	Signal name
01	+DB(12)	35	-DB(12)
02	+DB(13)	36	-DB(13)
03	+DB(14)	37	-DB(14)
04	+DB(15)	38	-DB(15)
05	+DB(P1)	39	-DB(P1)
06	+DB(0)	40	-DB(0)
07	+DB(1)	41	-DB(1)
08	+DB(2)	42	-DB(2)
09	+DB(3)	43	-DB(3)
10	+DB(4)	44	-DB(4)
11	+DB(5)	45	-DB(5)
12	+DB(6)	46	-DB(6)
13	+DB(7)	47	-DB(7)
14	+P_CRCA	48	-P_CRCA
15	Ground	49	Ground
16	DIFFSENS(*2)	50	Ground
17	TERMPWR(*1)	51	TERMPWR(*1)
18	TERMPWR(*1)	52	TERMPWR(*1)
19	Reserved	53	Reserved
20	Ground	54	Ground
21	+ATN	55	-ATN
22	Ground	56	Ground
23	+BSY	57	-BSY
24	+ACK	58	-ACK
25	+RST	59	-RST
26	+MSG	60	-MSG
27	+SEL	61	-SEL
28	+C/D	62	-C/D
29	+REQ	63	-REQ
30	+I/O	64	-I/O
31	+DB(8)	65	-DB(8)
32	+DB(9)	66	-DB(9)
33	+DB(10)	67	-DB(10)
34	+DB(11)	68	-DB(11)

Figure 19. Table of signals

NOTES: *1 TERMPWR can be disabled.

*2 HVD is not supported.

7.1.2.2 SCSI signal connector (80 pin SCA-2 model)

The 80 pin SCA-2 model uses a DDK connector which is compatible with SPI-3.

Connector contact number	Signal name	Connector contact number	Signal name
01	12 Volt Charge	41	12V Ground
02	12 Volt	42	12V Ground
03	12 Volt	43	12V Ground
04	12 Volt	44	MATED 1
05	Opt 3.3 V/NC	45	Opt 3.3 V charge/NC
06	Opt 3.3 V/NC	46	DIFFSENS(*1)
07	-DB(11)	47	+DB(11)
08	-DB(10)	48	+DB(10)
09	-DB(9)	49	+DB(9)
10	-DB(8)	50	+DB(8)
11	-I/O	51	+I/O
12	-REQ	52	+REQ
13	-C/D	53	+C/D
14	-SEL	54	+SEL
15	-MSG	55	+MSG
16	-RST	56	+RST
17	-ACK	57	+ACK
18	-BSY	58	+BSY
19	-ATN	59	+ATN
20	-P_CRCA	60	+P_CRCA
21	-DB(7)	61	+DB(7)
22	-DB(6)	62	+DB(6)
23	-DB(5)	63	+DB(5)
24	-DB(4)	64	+DB(4)
25	-DB(3)	65	+DB(3)
26	-DB(2)	66	+DB(2)
27	-DB(1)	67	+DB(1)
28	-DB(0)	68	-DB(0)
29	-DB(P1)	69	+DB(P1)
30	-DB(15)	70	+DB(15)
31	-DB(14)	71	+DB(14)
32	-DB(13)	72	+DB(13)
33	-DB(12)	73	+DB(12)
34	5 Volt	74	MATED 2
35	5 Volt	75	5V Ground
36	5 Volt Charge	76	5V Ground
37	Spindle Sync/NC	77	ACTIVE LED OUT
38	RMT START	78	DELAYED START
39	SCSI ID (0)	79	SCSI ID (1)
40	SCSI ID (2)	80	SCSI ID (3)

Figure 20. Table of signals

*NOTE*1: HVD is not supported.*

NOTE: SCA-2 connector is not mechanically compatible with the 68 pin "P" connector as defined in the ANSI SCSI standard. The connector is intended for direct back plane attachment and is not intended to be cable attached to the bus.

8 bit devices which connect to the SCA-2 connector should have the following signals inactive (high): -DB(8), -DB(9), -DB(10), -DB(11), -DB(12), -DB(13), -DB(14), -DB(15), -DB(P1). All other signals shall be connected as defined.

7.1.3 SCSI cable

Refer to ANSI SPI-3 T10/1302D Revision 11.

7.1.4 SCSI bus terminator

Onboard SCSI active termination feature is not supported. The using system is responsible for making sure that all required signals are terminated at both ends of the bus cable.

7.1.4.1 Terminator power

Termination power can be provided by drive 5V supply through current limiter and Schottky diode. This function can be selected by jumper.

80 pin SCA-2 models do not support SCSI bus termination power.

7.1.5 Hot plug/unplug

The term 'Hot Plug' refers to the action of mechanically engaging a device to the power and/or bus when other devices may be active on the same bus. A comprehensive classification of the state of the SCSI bus during this event is located in the SCSI-3 Parallel Interface Standard.

While every effort was made to design the drive not to influence the SCSI bus during these events, it is the responsibility of the system to insure voltage regulation and conformance to operational and non-operational shock limits. During Hot Plug events the non-operational shock levels should not be exceeded. The operational shock levels of adjacent drives should also not be exceeded. The recommended procedure is to prohibit write operations to adjacent drives during Hot Plug and Hot Unplug actions.

During Hot Unplug the operational shock limit specifications should not be exceeded. If this cannot be guaranteed then the drive should be issued a SCSI Stop Unit command that is allowed to complete before unplugging. The basic requirement is that while the drive is operational or spinning down the operational shock limits are in effect. Once the drive has completely stopped the non-operational shock limits are in effect. The recommended procedure is to allow the unplugged drive to rest in the drive bay for a minimum of 15 seconds and then complete the removal. During Hot Plug or Unplug events the power supply ripple on adjacent operational drives should not be outside the +/-5 % regulation tolerance.

7.1.6 SCSI bus electrical characteristics

Refer to ANSI SPI-3 T10/1302D Revision 11 for bus electrical characteristics.

NOTE: If the drive is connected to an HVD bus, the drive I/O will be permanently damaged.

7.1.7 Auxiliary connector on 68 pin model

The 68 pin models have an Auxiliary Connector between the power connector and the 68 pin SCSI connector in addition to the Option Jumper Block. The settings at the Option Jumper Block and the Auxiliary Connector work as logical OR. The drive conforms SFF-8009 Rev3.0.

- Pin #1,3,5,7 specify SCSI-ID as -DAS0,1,2,3. Tie-down to the ground is to assert.
- Pin #2,4,6,12 are reserved, and should be open.
- Pin #8 is for external LED cathode.

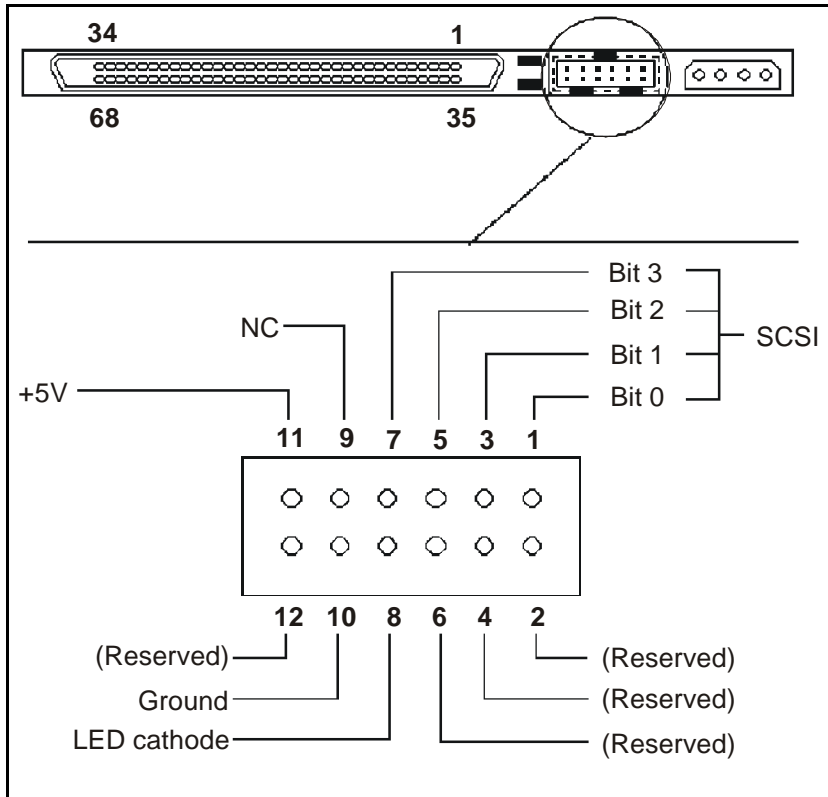

Figure 21. Auxiliary connector

7.2 Option jumper block

Two jumper blocks, **J-4** and **J-6**, are located on the card of **68/80 pin** models as shown in the figure below.

J-4 has 14 positions (#1 - #14) and controls Terminator Power supply.

As described in **Auxiliary connector on 68 pin model** on page 32, some of the jumper pins on J-4 of the 68 pin models can also be controlled through the Auxiliary Connector. These controls work as logical OR between the Option Jumper Block and the Auxiliary Connector.

As described in **SCSI signal connector (80 pin SCA-2 model)** on page 29, some of the jumper pins on J-4 of the 80 pin models can also be controlled through the 80 pin SCA-2 connector. These controls work as logical OR between the Option Jumper Block the SCA-2 connector.

J-6 has 14 positions (#1 - #14).

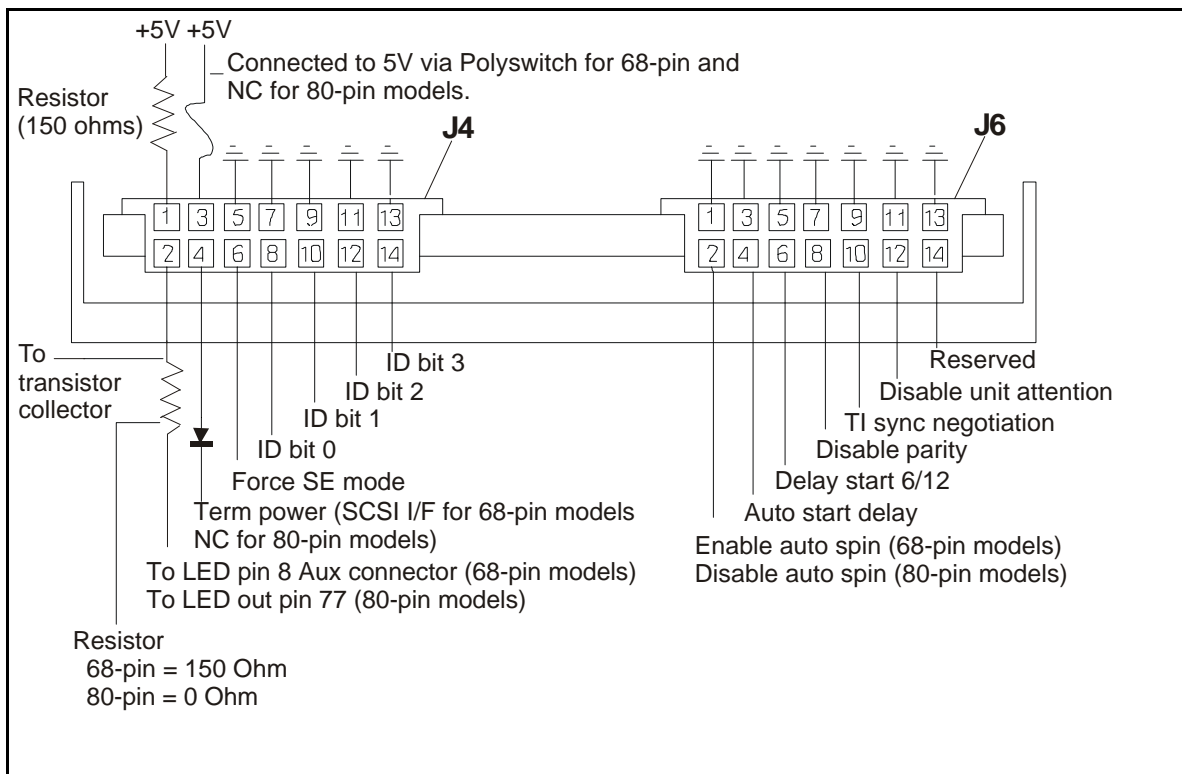

Figure 22. Jumper pins

Note: J4 pin 3 is connected to 5V via Polyswitch for 68 pin and NC for 80 pin models.

7.2.1 Jumper signal description on J6

7.2.1.1 Position #1-2 on J6

- 68 pin model

Enable Auto Spin Up

If a shunt jumper is installed, the drive will spin up automatically after power on reset. If shunt jumper is not installed, the drive will not spin up unless a START UNIT command is received.

- 80 pin model

Disable Auto Spin Up

If a shunt jumper is not installed, the drive will spin up automatically after power on reset. If shunt jumper is installed, the drive will not spin up unless a START UNIT command is received.

7.2.1.2 Position #3-4 and #5-6 on J6

Auto Start Delay & Delay Start 6/12

These pins control when and how the drive spins up with the combination of Position #1-2 on J6.

When both Auto Spin up and Auto Start Delay are enabled, the drive start will be delayed by a period of time multiplied by its own SCSI address. If Auto Spin up is disabled, these jumpers will be ignored.

Placing a jumper on delay start 6/12 results in a start up delay of 12 seconds times the SCSI ID.

Note: In the table below, 'on' means a shunt jumper is installed and 'off' means that a shunt jumper is not installed.

Model	Auto Start Delay	Auto Spin Up	Delay Start 6/12	Auto Start	Delay Multiplier
68 pin	off	off	off	NO	-
68 pin	off	on	off	YES	0
68 pin	on	off	off	NO	-
68 pin	on	on	off	YES	6
68 pin	off	off	on	NO	-
68 pin	off	on	on	YES	0
68 pin	on	off	on	NO	-
68 pin	on	on	on	YES	12
80 pin	off	off	off	YES	0
80 pin	off	on	off	NO	-
80 pin	on	off	off	YES	6
80 pin	on	on	off	NO	-
80 pin	off	off	on	YES	0
80 pin	off	on	on	NO	-
80 pin	on	off	on	YES	12
80 pin	on	on	on	NO	-

Figure 23. Auto Start Delay & Delay Start 6/12 drive behavior

7.2.1.3 Position #7-8 on J6

Disable SCSI Parity Check

Installing a jumper shunt disables SCSI Parity checking.

7.2.1.4 Position #9-10 on J6

Enable TI-SDTR

Installing a shunt jumper enables Target Initiated Synchronous Data Transfer Request Negotiation.

7.2.1.5 Position #11-12 on J6

Disable Unit Attention

Installing a shunt jumper enables control of UAI (Unit Attention Inhibit) bit in Mode Page 0.

7.2.1.6 Position #13-14 on J6

Reserved.

7.2.2 Jumper signal description on J-4

7.2.2.1 Position #1-2

LED pins

The LED pins are used to drive an external Light Emitting Diode. Up to 30 mA of sink current capability is provided. The LED Anode must be tied to the current limited + 5 V source provided on the pin for LED Anode at the Location #1 on J4 jumper block. The LED Cathode is then connected to the pin for LED Cathode at the Location #2 on J4 jumper block to complete the circuit.

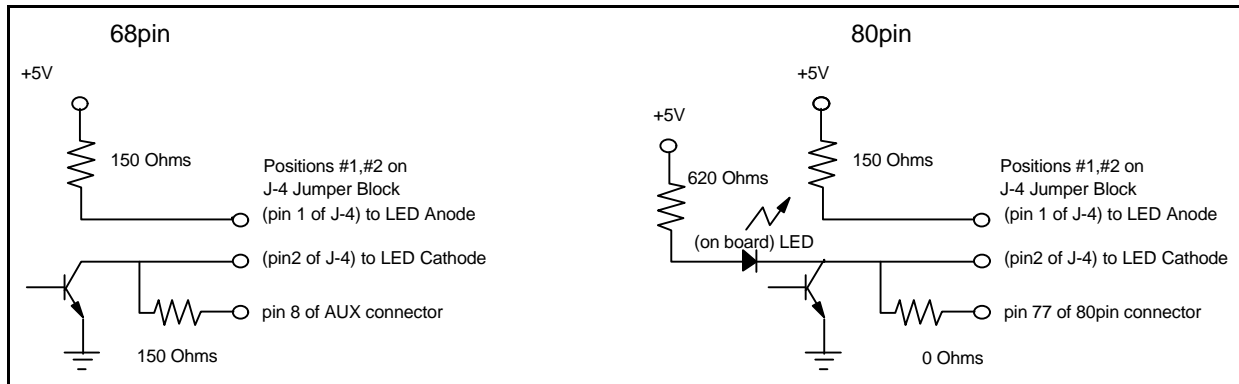

Figure 24. LED circuit

7.2.2.2 Position #3-4 on J4

Term Power

NC for 80 pin models. If a shunt jumper is installed on 68 pin models, termination power is supplied to pins 17, 18, 51, and 52 of the 68 pin SCSI interface.

7.2.2.3 Position #5-6 on J4

Force SE mode

If a shunt jumper is installed, the drive is forced to work as a single-ended mode drive.

7.2.2.4 Position #7-8 to #13-14 on J4

These four lines (-DAS0, -DAS1, -DAS2, -DAS3) define DPSS-3xxxxx device ID on the SCSI BUS.

-DAS0 is the least significant bit and -DAS3 is the most significant bit. Device ID is defined as follows:

Throughout this paragraph 'on' means a shunt jumper is installed and 'off' means that no shunt jumper is installed.

-DAS3 (1)	-DAS2 (2)	-DAS1 (3)	-DAS0 (4)	Device ID
off	off	off	off	0 - shipping default of 80 pin
off	off	off	on	1
off	off	on	off	2
off	off	on	on	3
off	on	off	off	4
off	on	off	on	5
off	on	on	off	6 - shipping default of 68 pin
off	on	on	on	7
on	off	off	off	8
on	off	off	on	9
on	off	on	off	10
on	off	on	on	11
on	on	off	off	12
on	on	off	on	13
on	on	on	off	14
on	on	on	on	15

Figure 25. SCSI device ID

7.3 Environment

Operating conditions	
Temperature	5 to 50°C (See note)
Relative Humidity	8 to 90%, non-condensing
Maximum Wet Bulb Temperature	29.4°C, non-condensing
Maximum Temperature Gradient	15°C/Hour
Altitude	-300 to 3048 m
Non-operating conditions	
Temperature	-40 to 65°C
Relative Humidity	5 to 95%, non-condensing
Maximum Wet Bulb Temperature	35°C, non-condensing
Maximum Temperature Gradient	15°C/Hour
Altitude	-300 to 12,000 m

Figure 26. Operating and non-operating conditions

NOTE: The system has to provide sufficient ventilation to maintain a surface temperature below 60 °C at the center of the drive top cover. Non-condensing conditions should be maintained at any time. Maximum storage period with shipping package is one year.

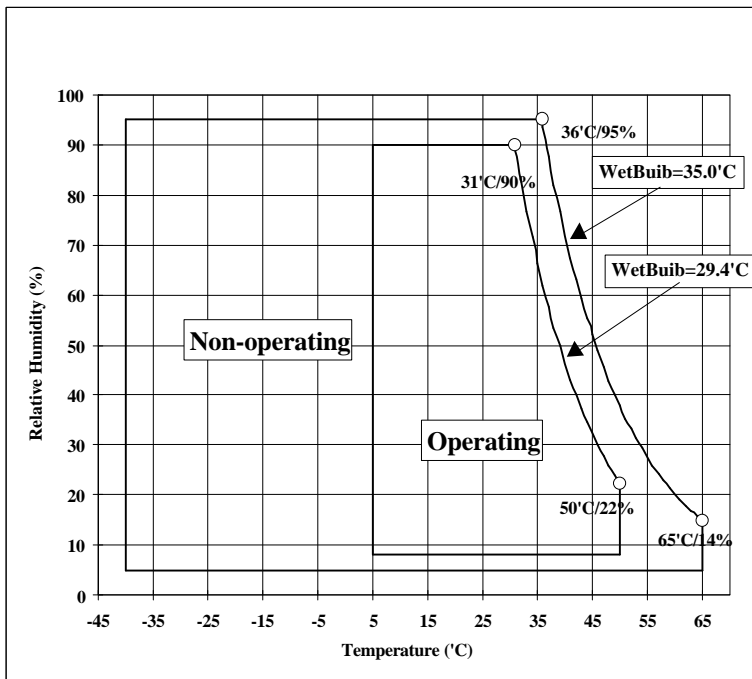

Figure 27. Temperature and relative humidity

7.3.1 Corrosion test

The hard disk drive shows no signs of corrosion inside or outside of the HDA and remains functional after 7 days of 50 °C temperatures and 90% relative humidity.

7.4 Cooling requirements

Drive component temperatures must remain within the limits specified in the following table. Maximum component temperature ratings must not be exceeded under any operating condition. The drive may require forced air cooling to meet specified operating temperatures.

Module name	Location	Maximum allowable surface temperature
MPU + HDC integration module	1	95°C
DRAM	2	90°C
VCM + Spindle Driver	4	95°C
Channel module	5	95°C

Figure 28. Maximum allowable module surface temperature

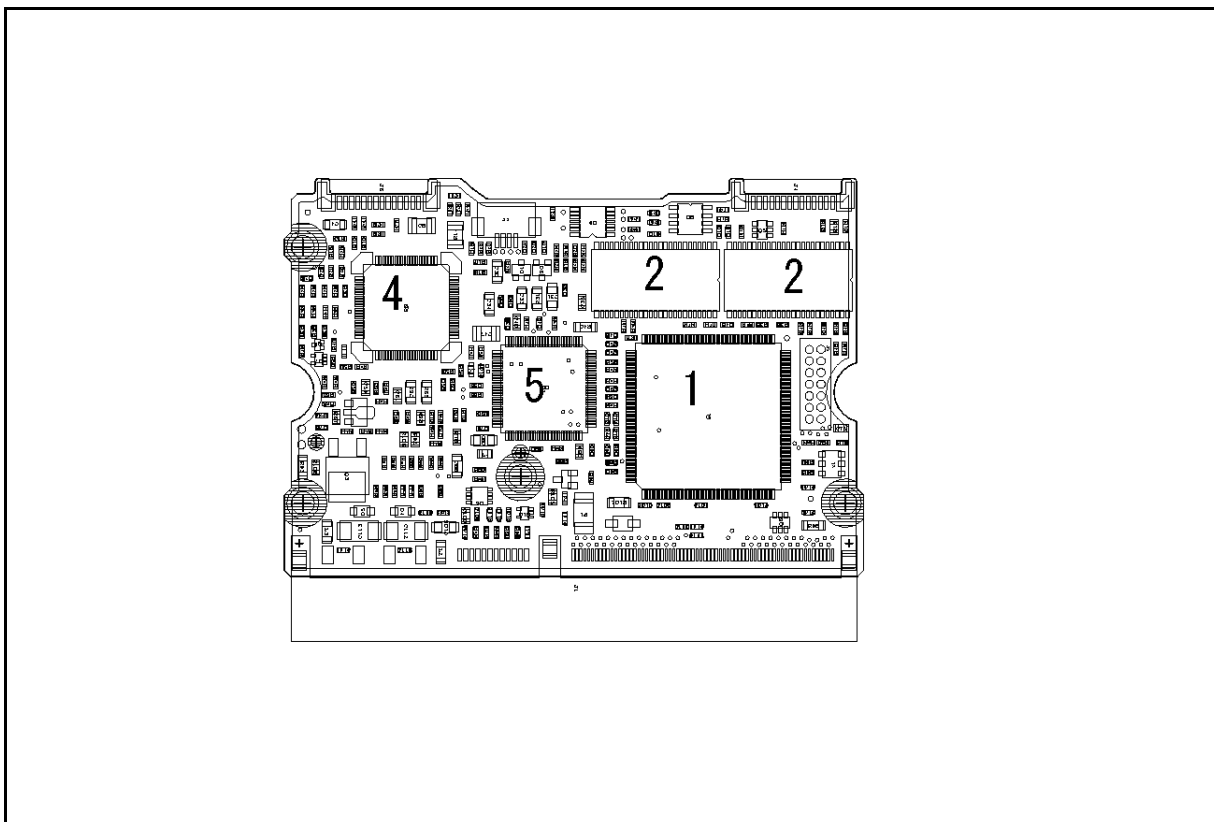

Figure 29. Module location

7.5 DC power requirements

The following voltage specification applies at the drive power connector. Connections to the drive should be made in a safety extra low voltage (SELV) circuit. There is no special power on/off sequencing required.

Adequate secondary over-current protection is the responsibility of the system. 10[A] limit is required for safety purpose.

7.5.1 Input voltage

	During run and spin up	Absolute max spike voltage	Supply rise time
+5 volts supply	5V +/- 5%	5.5V	0-200 ms
+12 volts supply	12V +/- 5% *	15V	0-400 ms

Figure 30. Input voltage

**NOTE: -8% is acceptable during spin up, but the spin up time is not guaranteed.*

CAUTION: To avoid damage to the drive electronics, power supply voltage spikes must not exceed 5.5V.

7.5.2 Power supply current

NOTE: Seek power is at 50 IOPS and R/W power is at 30 IOPS.

(All values in Amps.)	+5 Volts Pop Mean	+5 Volts Std. Dev	+12 Volts Pop Mean	+12 Volts Std. Dev	Total (W)
Idle Average	0.62	0.02	0.82	0.03	12.9
Idle ripple (peak-to-peak)	0.20	0.02	0.70	0.10	n/a
Seek average	0.65	0.02	1.25	0.03	18.3
Seek peak	0.93	0.05	2.30	0.10	n/a
Start up (max)	0.94	0.03	2.50	0.13	n/a
Random R/W peak	1.30	0.10	2.30	0.10	n/a
Random R/W average	0.75	0.02	1.10	0.03	17.0

Figure 31. Power supply current of DDYS-T36950

(All values in Amps.)	+5 Volts Pop Mean	+5 Volts Std. Dev	+12 Volts Pop Mean	+12 Volts Std. Dev	Total (W)
Idle Average	0.62	0.02	0.55	0.03	9.7
Idle ripple (peak-to-peak)	0.20	0.02	0.70	0.10	n/a
Seek average	0.65	0.02	1.25	0.03	18.3
Seek peak	0.93	0.05	2.30	0.10	n/a
Start up (max)	0.94	0.03	2.50	0.13	n/a
Random R/W peak	1.30	0.10	2.30	0.10	n/a
Random R/W average	0.75	0.02	0.86	0.03	14.1

Figure 32. Power supply current of DDYS-T18350

(All values in Amps.)	+5 Volts Pop Mean	+5 Volts Std. Dev	+12 Volts Pop Mean	+12 Volts Std. Dev	Total (W)
Idle Average	0.62	0.02	0.45	0.03	8.5
Idle ripple (peak-to-peak)	0.20	0.02	0.70	0.10	n/a
Seek average	0.65	0.02	1.25	0.03	18.3
Seek peak	0.93	0.05	2.30	0.10	n/a
Start up (max)	0.94	0.03	2.50	0.13	n/a
Random R/W peak	1.30	0.10	2.30	0.10	n/a
Random R/W average	0.75	0.02	0.82	0.03	13.6

Figure 33. Power supply current of DDYS-T09170

7.5.3 Ripple voltage

	Maximum	Notes
+5V DC	250 [mV pp]	0-10 [MHz]
+12V DC	250 [mV pp]	0-10 [MHz]

Figure 34. Power supply generated ripple at drive power connector

During drive start up and seeking, 12 volt ripple is generated by the drive (referred to as dynamic loading). If several files have their power daisy chained together then the power supply ripple plus other drive dynamic loading must remain within the regulation tolerance of $\pm 0.5\%$. A common supply with separate power leads to each drive is a more desirable method of power distribution.

To prevent external electrical noise from interfering with the drive's performance, the drive must be held by four screws in a user system frame which has no electrical level difference at the four screws position, and has less than ± 300 millivolts peak to peak level difference to the drive power connector ground.

7.5.4 Power consumption efficiency index

Model	DDYS-T36950	DDYS-T18350	DDYS-T09170
Power consumption efficiency index (Idle mode)	0.35 [W/GB]	0.53 [W/GB]	0.93 [W/GB]

Figure 35. Power consumption efficiency index

7.6 Reliability

7.6.1 Start/stop cycles

The drive is designed to withstand a minimum of 50,000 start/stop cycles at ambient environment.

The drive is designed to withstand a minimum of 10,000 start/stop cycles at operating environment conditions specified in page 38.

7.6.2 Data reliability

The probability of uncorrectable data error rate is 1 in 1×10^{14} bits read.

The following ECC on the fly correction is implemented:

- 1 Symbol : 8 bits
- 3 Interleave
- 5 ECCs are embedded in each interface
- 15 Symbols, 5 symbols per each interleave, for on the fly correction. This implementation always recovers 4 random burst errors and a 11.3 bit continuous burst error.

7.6.3 Seek/ID miscompare errors

A non-recoverable seek/ID miscompare error is defined as a seek operation that cannot be recovered by the error recovery procedure of the drive. The drive reports sense key 04 and sense code 02 for this error.

No drive has more than one non-recoverable seek/ID mis-compare error per 100 million seek operations (1 in 1×10^8) when operated at the full range of voltage and environmental conditions.

7.6.4 Equipment errors

A recoverable equipment error is any error other than a seek/ID mis-compare error or read error that is detected and corrected by the drive error recovery procedure. Examples are Write Fault, Drive Not Ready and internal drive errors.

No drive has more than one recoverable equipment error per 10^8 read, 10^6 write or 10^6 seek operations when operated at the full range of voltage and environmental conditions.

Non-recoverable equipment errors indicate a defective drive.

7.6.5 Failure prediction (PFA/S.M.A.R.T.)

DDYS-Txxxxx supports Informational Exceptions Control Page (1C) defined in SCSI-3. The function enables the drive to report sense codes of FAILURE PREDICTION THRESHOLD EXCEEDED to the host system.

The page 1C specifies enable/disable, reporting method, and report count.

In case the drive exceeded the failure prediction threshold, the drive returns Check Condition on any command. Then, per specified reporting method in Mode Page 1C, 0/5D/00, 1/5D/00 or 6/5D/00 as sense key/code/qualifier is sent to the host as a response of Request Sense command.

As the default, the function is enabled but no reporting of informational exception condition is made.

The details are described in **Mode Page 1C (Informational Exceptions Control)** on page 121.

7.6.6 Preventive maintenance

None.

7.6.7 Temperature Warning

Temperature Warning is enabled by setting EWASC (Enable Warning Additional Sense Code) bit to 1, and setting DEXCPT (Disable Exception Control) bit to 0 in Mode Page 1C. For mode page setting, refer to **Mode Page 1C (Informational Exceptions Control)** on page 121. The warning is informed as sense data (Sense Key 01h, Code 0Bh, Qual 01h).

The drive temperature can be detected by Log Sense Page 2F. Refer to **Log Sense Page 2F** on page 91.

7.7 Mechanical specifications

7.7.1 Outline

7.7.1.1 68 pin model

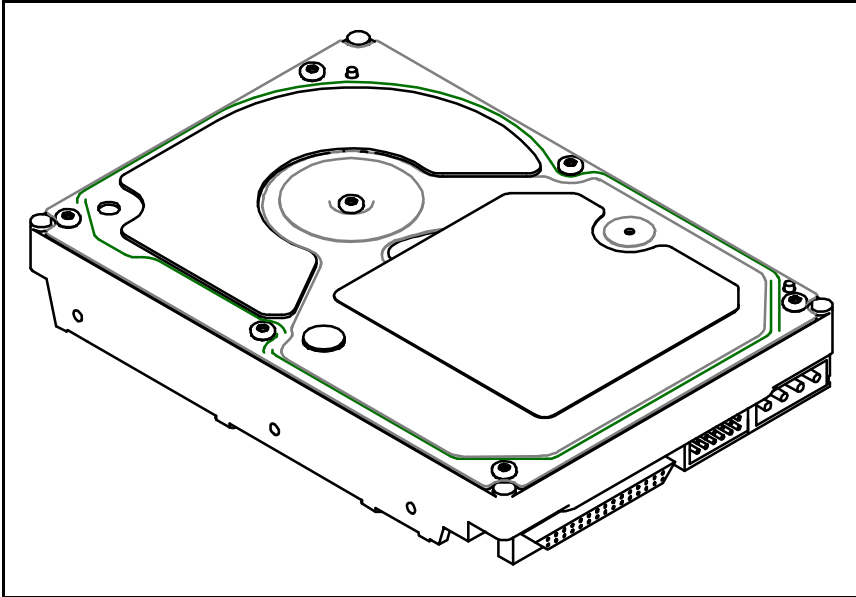

Figure 36. Outline of 68 pin model

7.7.1.2 80 pin model

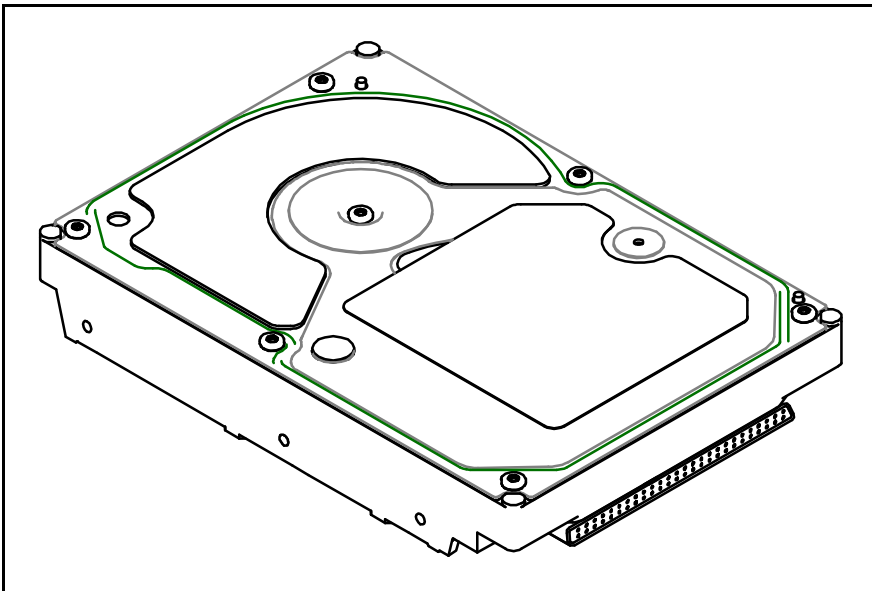

Figure 37. Outline of 80 pin model

7.7.2 Mechanical dimensions

DDYS-Txxxxx comply with SFF-8301 with one deviation in tolerance of width, $\pm 0.25\text{mm}$ vs $\pm 0.4\text{mm}$.

Height [mm]	25.4 +/- 0.4
Width [mm]	101.6 +/- 0.4
Length [mm]	146.0 +/- 0.6
Weight [gram]	700 Maximum

Figure 38. Physical dimensions

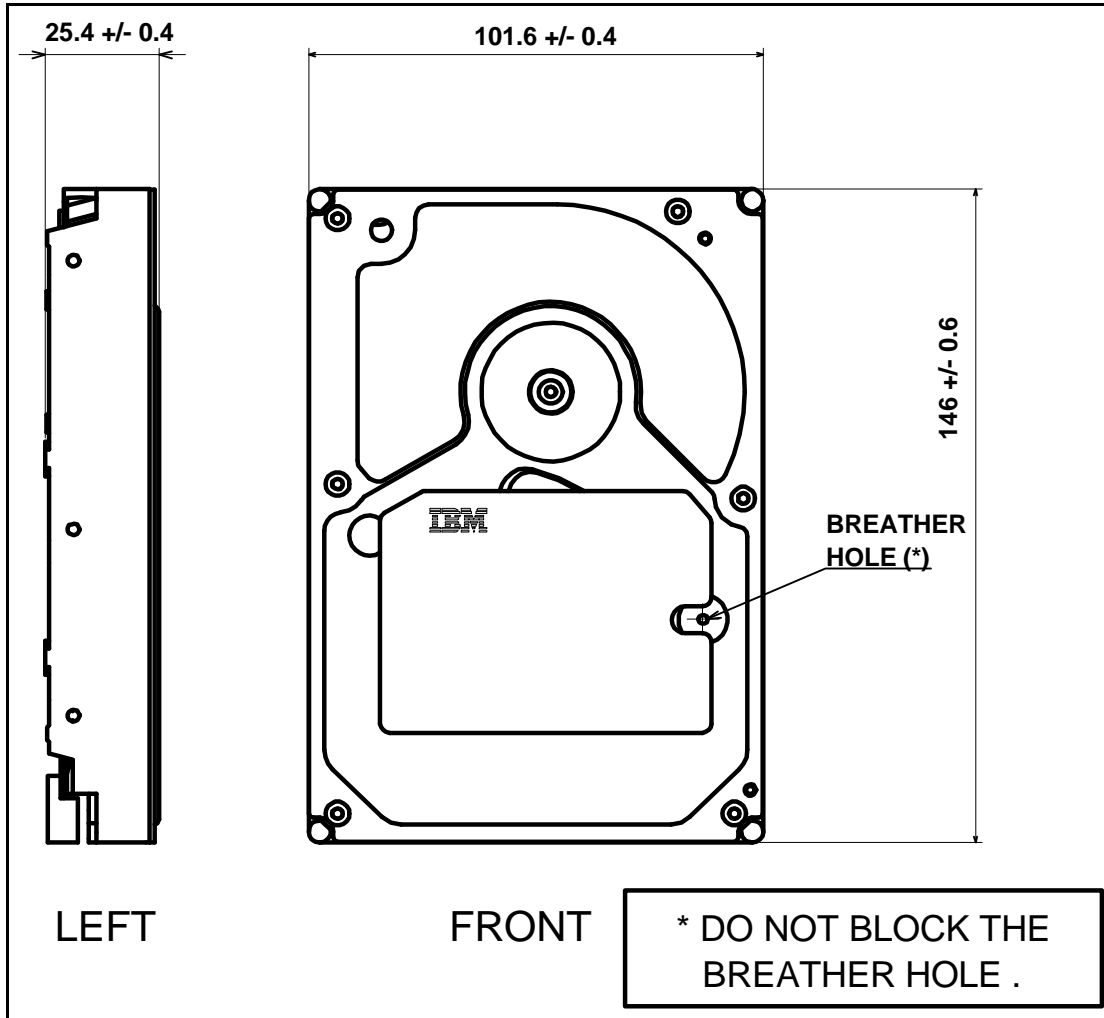

Figure 39. Mechanical dimensions

7.7.3 Interface connector

7.7.3.1 68 pin model

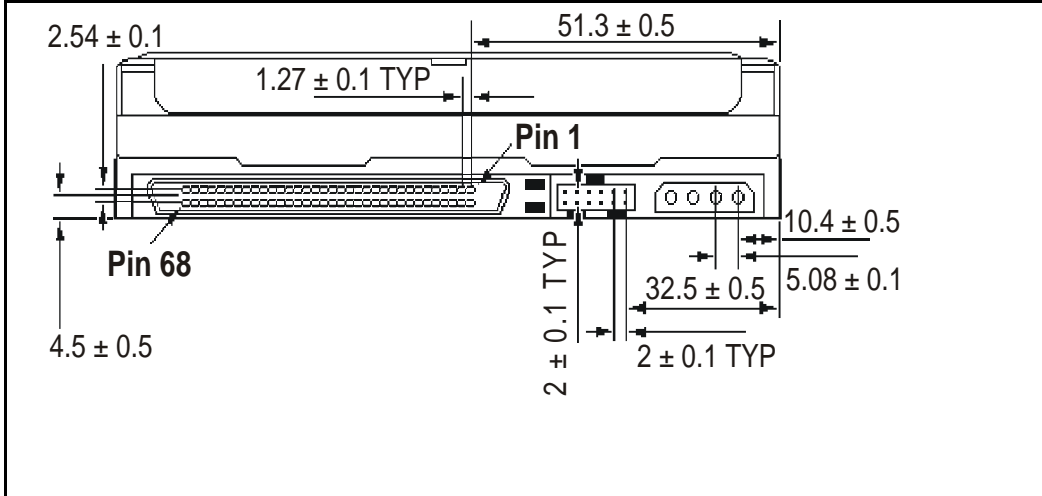

Figure 40. 68 pin model interface connector

7.7.3.2 80 pin model

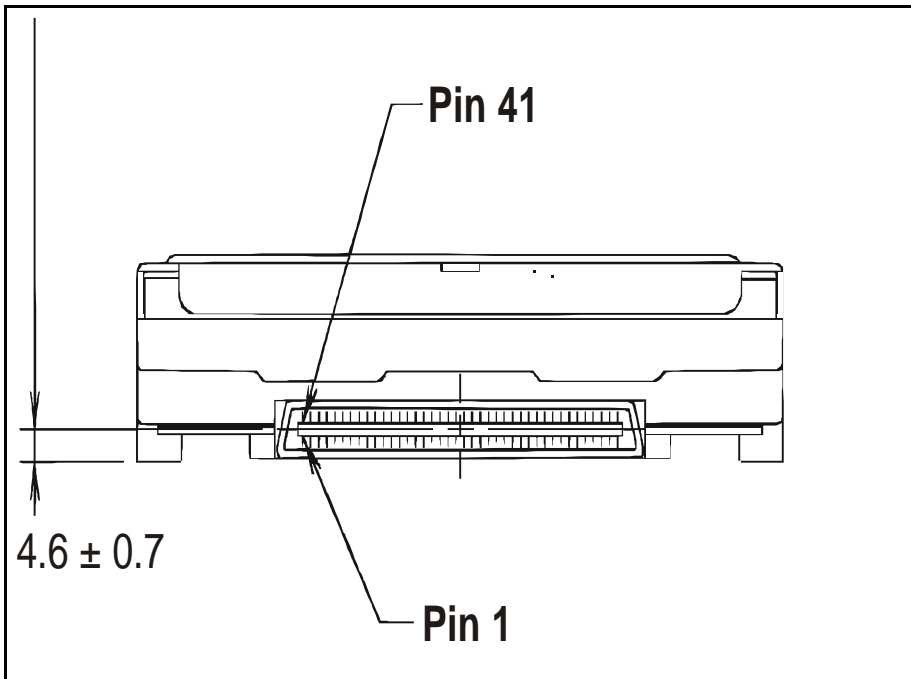

Figure 41. 80 pin model interface connector

7.7.4 Mounting positions and tappings

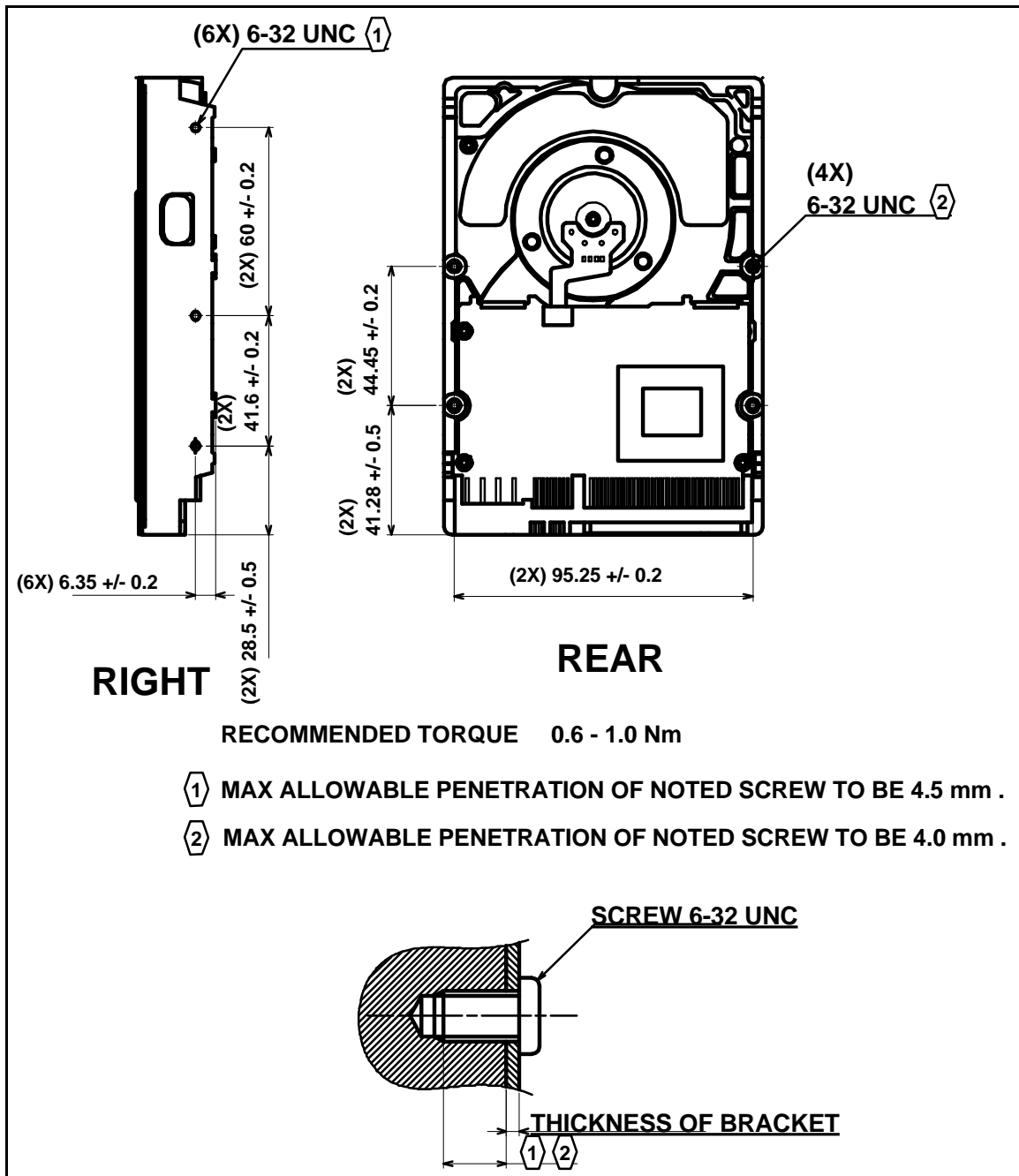

Figure 42. Mounting positions and tappings

7.7.4.1 Drive mounting

The drive will operate in all axes (6 directions). Performance and error rate will stay within specification limits if the drive is operated in the other orientations from which it was formatted.

The recommended mounting screw torque is 0.6 - 1.0 [Nm] (6 - 10 [Kgf.cm]). The recommended mounting screw depth is 4 [mm] Max for bottom and 4.5 [mm] Max for horizontal mounting.

To avoid performance degradation, mount the drive in the system **securely enough** to prevent excessive motion or vibration of the drive at seek operation or spindle rotation, using **appropriate screws** or equivalent mounting hardware. Consult with the issuer of this specification for actual application if necessary.

Drive level vibration test and shock test are to be conducted with the drive mounted to the table using the bottom four screws.

7.7.5 Heads unload and actuator lock

Heads are moved out from disks (unload) to protect the disk data during shipping, moving or storage. At power down, the heads are automatically unloaded from the disk area and the head actuator locking mechanism will secure the heads in the unload position.

7.7.6 Breather hole

The breather hole must be kept clear and unobstructed at all times. **Do not cover** the breather hole.

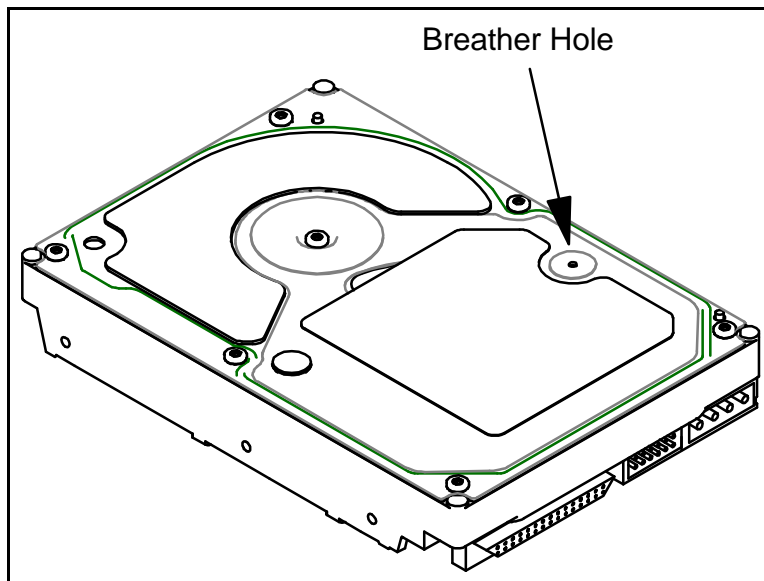

Figure 43. Breather hole location

7.8 Vibration and shock

All vibration and shock measurements in this section are made with a drive that has no mounting attachments for the systems. The input power for the measurements is applied to the normal drive mounting points.

7.8.1 Operating vibration

7.8.1.1 Random vibration

The drive is designed to operate without unrecoverable errors while being subjected to the following vibration levels.

The measurements are carried out during 30 minutes of random vibration using the power spectral density (PSD) levels as following.

Random vibration PSD profile breakpoints (operating)

Direction	5 Hz	17 Hz	45 Hz	48 Hz	62 Hz	65 Hz	150 Hz	200 Hz	500 Hz	RMS (G)
Horizontal $\times 10^3$ [G ² /Hz]	0.02	1.1	1.1	8.0	8.0	1.0	1.0	0.5	0.5	0.67
Vertical $\times 10^3$ [G ² /Hz]	0.02	1.1	1.1	8.0	8.0	1.0	1.0	0.08	0.08	0.56

Figure 44. Random vibration PSD profile breakpoints (operating)

Overall RMS (root mean square) level of horizontal vibration is 0.67G RMS.

Overall RMS (root mean square) level of vertical vibration is 0.56G RMS.

NOTE: The specified levels are measured at the mounting points.

7.8.1.2 Swept sine vibration

The hard disk drive will meet the criteria shown below while operating in respective conditions.

No errors 0.5 G 0-peak, 5-300-5 Hz sine wave, 0.5 oct/min sweep rate
with 3 minute dwells at 2 major resonances

No data loss 1 G 0-peak, 5-300-5 Hz sine wave, 0.5 oct/min sweep rate
with 3 minute dwells at 2 major resonances

7.8.2 Non-operating vibrations

The drive does not sustain permanent damage or loss of recorded data after being subjected to the environment described below.

7.8.2.1 Random vibration

The test consists of a random vibration applied for each of three mutually perpendicular axes with the time duration of 10 minutes per axis. The PSD levels for the test simulates the shipping and relocation environment which is shown below.

Random vibration PSD profile breakpoints (non-operating)

Frequency	2 Hz	4 Hz	8 Hz	40 Hz	55 Hz	70 Hz	200 Hz	RMS (G)
[G ² /Hz]	0.001	0.03	0.03	0.003	0.01	0.01	0.001	1.04

Figure 45. Random vibration PSD profile breakpoints (non-operating)

Overall RMS (Root Mean Square) level of vibration is 1.04G (RMS).

The disk drive does not sustain permanent hardware damage or loss of previously recorded data after being subjected to the environment described above.

7.8.2.2 Swept sine vibration

- 2 G (Zero to peak), 5 to 500 to 5 Hz sine wave
- 0.5 oct/min sweep rate
- 3 minutes dwell at two major resonances

7.8.3 Operating shock

The drive meets the following criteria:

- No data loss with 10G, 11msec half-sine shock pulse
- No data loss with 45G, 2msec half-sine shock pulse

The shock pulses of each level are applied to the drive, ten pulses for each direction and for all three axes. There must be a minimum of 30 seconds delay between shock pulses. The input level is applied to a base plate where the drive is attached with four screws.

7.8.4 Non-operating shock

The drive withstands the following square shock pulse with no permanent damage:

- Accelerating level of 50 G
- Duration time of 11 ms
- Rise and fall time of 1 ms
- Minimum velocity change of 4.23ms

The drive withstands the following half-sine shock pulse:

- No data loss with 75G, 11ms
- No data loss with 225G, 2ms

The shocks are applied in each direction of the drive for three mutually perpendicular axes and one axis at a time. Input levels are measured on a base plate where the drive is attached with four screws.

The drive withstands the following **Rotational Shock**:

- No data loss with Rotational Shock 30000rad/s^2 , 1ms applied around the axis of actuator pivot.

NOTE: Actuator is automatically locked at power-off to keep the heads on a landing zone.

7.9 Acoustics

7.9.1 Sound power levels

The upper limit criteria of the A-weighted sound power levels are given in Bel relative to one pico watt and are shown in the following table. The measurement method is in accordance with ISO7779. Drives are to meet this criteria in both board up and board down orientations.

Mode	A-weighted sound power level [Bel]	
Idle	3.9 (Typical)	4.3 (Max)
Operating	4.8 (Typical)	5.0 (Max)

Figure 46. A-weighted sound power levels

Background power levels of the acoustic test chamber for each octave band are to be recorded. Sound power levels are measured with the drive supported by spacers so that the lower surface of the drive is located 25 ± 3 mm height from the chamber desk. No sound absorbing material shall be used. The acoustical characteristics of the drive subsystem are measured under the following conditions.

Idle mode:

Powered on, disks spinning, track following, unit ready to receive and respond to control line commands.

Operating mode:

Continuous random cylinder selection and seek operation of the actuator with a dwell time at each cylinder. Seek rate for the drive is to be calculated as listed below;

$$N_s = 0.4 / (T_t + T_I)$$

N_s = average seek rate in seeks/sec.

T_t = published random seek time.

T_I = time for the drive to rotate by half a revolution.

7.10 Identification labels

The following labels are affixed to every hard disk drive shipped from the drive manufacturing location in accordance with appropriate hard disk drive assembly drawing:

- A label containing IBM logo, IBM part number and the statement “Made by IBM Japan Ltd.”, or IBM approved equivalent.
- A label containing drive model number, manufacturing date, formatted capacity, country of origin or IBM approved equivalent and UL/CSA/TUV/CE CTICK logos.
- A bar code label containing the drive serial number.
- Jumper setting label.
- A user designed label, per agreement.
- Interface definition mark, SCSI LVD/SE multimode

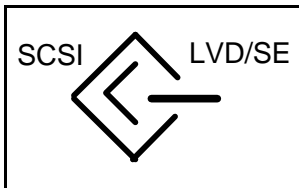

Figure 47. Interface definition mark, SCSI LVD/SE multimode

The labels may be integrated with other labels.

7.11 Electromagnetic compatibility

The drive, when installed in a suitable enclosure and exercised with a random accessing routine at maximum data rate, meets the worldwide EMC requirements listed below.

IBM will provide technical support to meet the requirements to comply with the EMC specifications.

- United States Federal Communications Commission (FCC) Rules and Regulations (Class B), Part 15. IBM Corporate Standard C-S 2-0001-005
- CISPR Publication 22; 1993 (Class B)
- CISPR Publication 22, Amendment 1, 1995
- CISPR Publication 22, Amendment 2, 1996
- Electrostatic Discharge Susceptibility limits for a Class 2 ESD environment specified in IBM Corporate Standard C-S 2-0001-005
- Radiated Electromagnetic Susceptibility (RES) as specified in IBM Corporate Standard C-S 2-0001-012.

7.11.1 CE Mark

The product is declared to be in conformity with requirements of the following EC directives under the sole responsibility of IBM United Kingdom Ltd. or Yamato Lab, IBM Japan Ltd.

Council Directive 89/336/EEC on the approximation of laws of the Member States relating to electromagnetic compatibility.

7.11.2 C-Tick Mark

The product complies with the following Australian EMC standard.

- Limits and methods of measurement of radio disturbance characteristics of information technology equipment, AS/NZS 3548:1995 Class B.

7.12 Safety

The following shows the safety standards for different countries.

7.12.1 UL and CSA standard conformity

The product is qualified per UL1950 third edition and CAN/CSA C22.2 No. 950-95 third edition, for the use in Information Technology Equipment, including Electric Business Equipment. The UL recognition, or the CSA certification, is maintained for the product life. The UL and C-UL recognition mark, or CSA monogram for CSA certification, appears on the product.

7.12.2 IEC Compliance

The product is certified for compliance to IEC 950. The product will comply with these IEC requirements for the life of the product.

7.12.3 German Safety Mark

All Ultrastar 36LZX are to be approved by TUV on Test requirement: EN 60950, but the GS mark is not applicable to internal devices such as these drives.

7.12.4 Flammability

The printed circuit boards used in this product are made of material with the UL recognized flammability rating of V-1 or better. The flammability rating is marked or etched on the board. All other parts not considered electrical components are made of material with the UL recognized flammability rating of V-1 or better. However, small mechanical parts such as cable ties, washers, screws, and PC board mounts may be made of material with a UL recognized flammability rating of V-2.

8.0 SCSI Command Set

Summaries of the SCSI commands supported by the drive are listed below. O = optional, M = mandatory.

Type	Code	Description
M	04h	FORMAT UNIT
M	12h	INQUIRY
O	4Ch	LOG SELECT
O	4Dh	LOG SENSE
O	15h	MODE SELECT (6)
O	55h	MODE SELECT (10)
O	1Ah	MODE SENSE (6)
O	5Ah	MODE SENSE (10)
O	5Eh	PERSISTENT RESERVE IN
O	5Fh	PERSISTENT RESERVE OUT
O	34h	PRE-FETCH
M	08h	READ
O	3Ch	READ BUFFER
M	25h	READ CAPACITY
O	37h	READ DEFECT DATA (10)
O	B7h	READ DEFECT DATA (12)
M	28h	READ EXTENDED
O	3Eh	READ LONG
O	07h	REASSIGN BLOCKS
O	1Ch	RECEIVE DIAGNOSTICS
M	17h	RELEASE (6)
O	57h	RELEASE (10)
O	A3h	REPORT DEVICE IDENTIFIER
O	A0h	REPORT LUN
M	03h	REQUEST SENSE
M	16h	RESERVE (6)
O	56h	RESERVE (10)
O	01h	REZERO UNIT
O	0Bh	SEEK
O	2Bh	SEEK EXTENDED
M	1Dh	SEND DIAGNOSTICS
O	1Bh	START/STOP UNIT
O	35h	SYNCHRONIZE CACHE
M	00h	TEST UNIT READY
O	2Fh	VERIFY
M	0Ah	WRITE
O	2Eh	WRITE AND VERIFY
O	3Bh	WRITE BUFFER
M	2Ah	WRITE EXTENDED
O	3Fh	WRITE LONG
O	41h	WRITE SAME

Figure 48. Supported SCSI commands

8.1 SCSI Control Byte

The Control Byte is the last byte of every CDB. The format of this byte is shown below.

Bit							
7	6	5	4	3	2	1	0
VU = 0		Reserved = 0				FLAG	LINK

Figure 49. SCSI Control Byte

VU VU stands for Vendor Unique.

FLAG The Flag bit specifies which message the target shall return to the initiator if the link bit is one and the command completes without any error. If Link is zero, Flag must also be zero. If Link is one and the command terminates successfully, the drive will send either the LINKED COMMAND COMPLETE message (FLAG=0) or the LINKED COMMAND COMPLETE WITH FLAG message (FLAG=1). Typically this bit is used to cause an interrupt in the initiator between linked commands.

LINK This bit is set to one to indicate that the initiator desires an automatic link to the next command upon successful completion of the current command. Upon successful completion of the command, the drive will return INTERMEDIATE GOOD status and then send one of the two messages defined under Flag above.

Upon unsuccessful completion of the command, the drive will return CHECK CONDITION status or RESERVATION CONFLICT status and then send the COMMAND COMPLETE message. No further commands in the chain are executed.

8.2 Abbreviations

These abbreviations are used throughout the following sections.

LUN Logical Unit Number. An encoded three bit identifier for the logical unit

VU Vendor Unique bits

LBA Logical Block Address

RSVD Reserved

MSB Most Significant bit

LSB Least Significant bit

8.3 Byte ordering conventions

In this specification, where it is not explicitly stated, all multibyte values are stored with the most significant byte first. For example in a 4 byte field byte 0 will contain the MSB and byte 3 the LSB.

8.4 FORMAT UNIT (04)

Byte	Bit							
	7	6	5	4	3	2	1	0
0	Command Code = 04h							
1	Reserved		FmtData	CmpList	Defect List Format			
2	VU = 0							
3 4	(MSB)		Interleave Factor				(LSB)	
5	VU = 0		Reserved = 0			FLAG	LINK	

Figure 50. FORMAT UNIT (04)

The FORMAT command performs a physical formatting of the drive media. This includes handling defective sectors and overwriting all data areas with a constant data pattern. (Reserved areas of the media are not affected by the FORMAT command.)

- **FmtData** set to one specifies that a Data Out phase follows the Command phase. FmtData set to zero specifies that no Data Out phase follows.
- **CmpList** set to one specifies that the GList (Grown Defect List) existing prior to the format **not** be used and is discarded. The drive is formatted with PList and DList (if specified). DList becomes the new GList.

Note: The drive manages two internal defect lists and one external. The primary defect list (“P”List) is created at time of manufacture. The grown defect list (“G”List) is built after manufacture by the Initiators use of the REASSIGN BLOCK command and the Automatic Reallocate functions. The data defect list (“D”List) is an external list. It is supplied by the initiator in the DATA OUT phase of the FORMAT UNIT command.

- **Defect List Format** specifies the format of the defect descriptor transferred to the Target when FmtData bit is set to one. The Target supports three defect descriptor formats for the Format Unit command as following:

Format Description

- 000b** Block format
- 100b** Bytes From Index format
- 101b** Physical Sector format

If the FmtData bit is set to zero, this field must also be zero. Otherwise the command will complete with a check condition with a sense key of illegal request and an additional sense code of invalid field in CDB.

- **Interleave Factor** may be zero or one, either of which specifies an interleave of 1:1. Other Interleave Factors are ignored because of the extensive buffering implemented in the drive.

8.4.1 Defect list

Following is the format of the Defect List Header sent during the data out phase when FmtData is set to one.

Byte	Bit							
	7	6	5	4	3	2	1	0
0	Reserved = 0							
1	FOV	DPRY	DCRT	STPF = 1	IP = 0	DSP = 0	Immed	0
2 3	(MSB) Defect List Length							(LSB)

Figure 51. Format of Defect List Header

The Target has a limited implementation of the Format Option bits located in Bits 2 through 7 of Byte 1 of the Defect List Header (See Figure 48). If the Initiator attempts to select any function not implemented by the Target, the Target terminates the command with Check Condition Status. The sense key is set to Illegal Request and the additional sense code is set to Invalid Field in Parameter List.

- **FOV** (Format Options Valid) bit of zero causes the Target to verify that the setting for the DPRY (Disable Primary), DCRT (Disable Certification), STPF (Stop Format), IP (Initialize Pattern), and DSP (Disable Saving Parameters) bits are zero. If any of these bits are not zero, the Target terminates the command with Check Condition Status. The sense key is set to Illegal Request and the additional sense code is set to Invalid Field in Parameter List.

Note: When FOV bit is one, three combinations of the DPRY, DCRT, STPF, IP and DSP bits are allowed. Any other combinations return a Check Condition Status With a sense key of Illegal Request and an additional sense code of Invalid Field In Parameter List. The supported combination are:

```
DPRY=0   DCRT=1   STPF=1   IP=0   DSP=0
DPRY=1   DCRT=1   STPF=1   IP=0   DSP=0
DPRY=0   DCRT=0   STPF=1   IP=0   DSP=0
```

- **DPRY** (Disable Primary) bit set to zero indicates that the Target does not use portions of the medium identified as defective in the primary defect PList for Initiator addressable logical blocks. If the Target cannot locate the PList or it cannot determine whether a PList exists, the target terminates the Format Unit command as described for STPF=1. A DPRY bit of one indicates that the Target does not use the PList to identify defective areas of the medium. The PList is not deleted.
- **DCRT** (Disable Certification) bit of ZERO indicates that the Target performs a medium certification operation and generates a Certification List (CList) and the Target adds the CList to the GList. A DCRT bit of one indicates that the Target does not generate a CList (Certification List) nor perform a certification process while executing the Format Unit Command.

Note: Since the DCRT bit is part of the Data Out phase that follows the format command, the FCERT bit in Mode Page 0 is provided to control certification when the format command is issued with no Data Out phase. If a format command is issued with a Data Out phase then FCERT is ignored.

- **STPF** (Stop Format) bit must be set to one. If one or both of the following conditions occurs, the Target terminates the Format Unit command with Check Condition Status. The sense key is set to Medium Error and the additional sense code is set to either Defect List Not Found if the first condition occurred or it is set to Defect List Error if the second condition occurred.
 1. The Target cannot locate a required defect list nor determine that the list exists.
 2. The Target encounters an unrecoverable error while accessing a required defect list.
- **IP** (Initialization Pattern) bit must be set to zero. The Target initializes all data with zeros.
- **DSP** (Disable Saving Parameters) bit must be set to zero. The Target saves all the Mode Select savable parameters during the format operation.
- **Immed** (Immediate) bit set to zero requests that status be returned at the end of the format operation. An immediate bit set to one requests that status be returned immediately. Good Status is returned following the CDB validation and transfer of data in the Data Out phase. If the immediate format operation terminates in error, Deferred Error Sense data is generated. With the immediate bit set to one, the Link bit must be set to zero.

8.4.2 Defect descriptor

The Defect List Length field specifies the total length in bytes of the defect descriptors that follow. The Target has an implementation limitation for the number of defect descriptors. The number of defect descriptors shall be less than 128. The defect list length must be equal to four times the number of defect descriptors to follow for the BLOCK format or eight times the number of defect descriptors to follow for the BYTES FROM INDEX and PHYSICAL SECTOR format. Otherwise the command is terminated with Check Condition Status, the sense key is set to Illegal Request, and the additional sense code is set to Invalid Field In Parameter List. The defect descriptors must specify the defect based on the current Format Device parameters reported by the Mode Sense command.

The Target supports three Defect List formats.

8.4.2.1 Block format

The Block format of the defect list supported by the drive is by logical block where the location of defective sectors is given by their LBA.

Byte	Bit							
	7	6	5	4	3	2	1	0
0	(MSB)							
1	Defective Logical Block Address							
2								
3								
4n - 4n +3	Defective Logical Block Address n							

Figure 52. Defect descriptor - Block format.

Format of the defect list sent during the data out phase when FmtData set to one.

8.4.2.2 Bytes From Index format

Each defect descriptor for the Bytes From Index format specifies that the sector containing this byte be marked defective. The defect descriptor is comprised of the cylinder number of the defect, the head number of the defect, and the defect bytes from index.

Byte	Bit							
	7	6	5	4	3	2	1	0
0	(MSB) Cylinder Number of Defect (LSB)							
1								
2								
3	Head Number of Defect							
4	(MSB) Defect Bytes from Index (LSB)							
5								
6								
7								
8n - 8n +7	Defect Descriptor n							

Figure 53. Defect descriptor - Bytes from Index format.

Format of the defect list sent during the data out phase when FmtData is set to one.

8.4.2.3 Physical Sector format

Each defect descriptor for the Physical Sector format specifies a defect that is the length of a sector. The defect descriptor is comprised of the cylinder number of the defect, the head number of the defect, and the defect sector number.

Byte	Bit							
	7	6	5	4	3	2	1	0
0	(MSB) Cylinder Number of Defect (LSB)							
1								
2								
3	Head Number of Defect							
4	(MSB) Defect Sector Number (LSB)							
5								
6								
7								
8n - 8n + 7	Defect Descriptor n							

Figure 54. Defect descriptor - Physical Sector format.

Format of the defect list sent during the data out phase when FmtData set to one.

8.5 INQUIRY (12)

Byte	Bit							
	7	6	5	4	3	2	1	0
0	Command Code = 12h							
1	Reserved			Reserved = 0			CmdDt	EVPD
2	Page Code							
3	Reserved = 0							
4	Allocation Length							
5	VU =0		Reserved = 0				FLAG	LINK

Figure 55. INQUIRY (12)

The INQUIRY command requests the parameters of the target to be sent to the initiator.

A CmdDT bit of one specifies that the file shall return the command support data information identified by the Page Code field in the CDB.

An EVPD bit of one specifies that the drive return the vital product data page identified by the Page Code field in the CDB¹. **Page code** specifies which page of vital product data information the drive shall return.

¹ The available VPD pages are defined in the addendum provided for each different drive model in the section entitled *Inquiry Data Format*.

CmdDt	EVPD	PAGE CODE	Description
0	0	0	The drive returns the standard INQUIRY data.
0	0	Non Zero	The drive returns CHECK CONDITION status with the sense key of ILLEGAL REQUEST and the additional sense code of INVALID FIELD IN CDB.
0	1	Supported	The drive returns the vital product data of page code requested.
0	1	Unsupported	The drive returns CHECK CONDITION status with the sense key of ILLEGAL REQUEST and the additional sense code of INVALID FIELD IN CDB
1	0	Supported	The drive returns command support data of page code requested.
1	0	Unsupported	The drive returns CHECK CONDITION status with the sense key of ILLEGAL REQUEST and the additional sense code of INVALID FIELD IN CDB.
1	1	Any values	The drive returns CHECK CONDITION status with the sense key of ILLEGAL REQUEST and the additional sense code of INVALID FIELD IN CDB.

Figure 56. Page code descriptions

Allocation Length specifies the number of bytes that the initiator has allocated for INQUIRY data to be returned. An allocation length of zero implies that no data returned. The drive will terminate the DATA IN phase when all available INQUIRY data has been transferred or when allocation length bytes have been transferred, whichever is less.

If an INQUIRY command is received from an initiator with a pending unit attention condition (before the target reports CHECK CONDITION status), the drive processes the INQUIRY command. The unit attention condition is not cleared by this action.

8.5.1 INQUIRY DATA

Fields with a value shown inside quotes (e.g. Value = 'xyz') are character fields. A value not in quotes is a numeric value. Character fields are alphanumeric and represented in either ASCII or EBCDIC as stated.

8.5.1.1 Inquiry data format - CmdDt = 0 EVPD = 0

Byte	Bit							
	7	6	5	4	3	2	1	0
0	Qualifier = 0			Peripheral Device Type = 0				
1	RMB=0	Device-Type Modifier = 0						
2	ISO = 0		ECMA = 0			ANSI = 3		
3	RSVD = 0	TrmTsk = 0	Norm ACA=0	RSVD = 0	Response Data Format = 2			
4	Additional Length = 159 (9Fh)							
5	Reserved = 0							
6	RSVD = 0	EncSer = 0	RSVD = 0	Multip = 0	MChngr = 0	ACKREQ = 0	Addr32 = 0	Addr16
7	REL_A = 0	Wb_32 = 0	Wb_16	Sync = 1	Link = 1	TTD = 0	CmdQu = 1	RSVD = 0
8-15	Vendor ID = 'IBM ' (ASCII)							
16-31	Product ID (ASCII)							
32-35	Product Revision Level (ASCII)							
36-43	Unit Serial Number (ASCII)							
44-52	Reserved = 0							
53	Reserved = 0				Clocking=11b	QAS=0	IUS=0	
54-95	Reserved = 0							
96-145	Copyright Notice (ASCII)							
146-163	Reserved = 0							

Figure 57. INQUIRY Data - CmdDt = 0EVPD = 0

- **Qualifier** is set to zero to indicate that the LUN specified in the Identify Message is currently supported. Qualifier is set to 011b when the LUN specified in the Identify Message is not present.²
- **Peripheral Device Type** is set to zero to indicate that the device is Direct Access. Peripheral Dev. Type is set to 1Fh when the LUN specified in the Identify Message is not present.
- **Removal Media Bit (RMB)** is always set to zero to indicate no removal media exist.
- **Device-Type Modifier** is set to zero.
- **ISO** is set to zero to indicate that this product does not claim compliance to the International Organization for Standardization (ISO) version of SCSI (ISO DP 9316).
- **ECMA** is set to zero to indicate that this product does not claim compliance to the European Computer Manufacturers Association (ECMA) version of SCSI (ECMA-111).
- **ANSI** indicates the level of the ANSI standard that is supported by the product. The drive supports ANSI SCSI version 3.
- **TrmTsk** (Terminate Task) field of 0 indicates the Target does not support the TERMINATE TASK task management function as defined in the SAM.
- **NormACA** (Normal ACA) field of 0 indicates the device server does not support setting the NACA bit to one in the Control Byte of the CDB as defined in the SAM.
- **Response Data Format** is set to two to indicate that the Inquiry Data Format as specified in ANSI SCSI version 2 is supported by the drive.
- **Additional Length** indicates the number of bytes of inquiry information that follows.
- **EncSer** (Enclosure Services) bit of 0 indicates that the Target does not contain an embedded enclosure service component.
- **MultiP** (MultiPort) bit of 0 indicates that the Target has a single port and does not implement multi-port requirements.
- **MChngr** (Medium Changer) bit is only supported when the RMB bit is one.
- **ACKREQQ** (ACKQ/REQQ) bit of 0 indicates that the Target does not support a request and acknowledge data transfer handshake on a Q cable.
- **Addr32** (Wide SCSI Address 32) bit of 0 indicates that the Target does not support 32 bit wide SCSI Addresses.
- **Addr16** (Wide SCSI Address 16) bit of 1 indicates that the Target supports 16 bit wide SCSI Addresses.
- **REL_A** is set to zero to indicate that the drive does not support 'Relative Address Mode'.
- **Wb_32** is set to zero to indicate that the drive does not support 32-bit wide data transfers.
- **Wb_16** is set to one to indicate that the drive supports 16-bit wide data transfers. Wb_16 is set to zero to indicate that the drive does not support 16-bit wide data transfers.
- **Sync** is set to one to indicate that the drive supports synchronous data transfer.
- **Link** is set to one to indicate that the drive supports linked commands.
- **TTD** is set to zero to indicate that the drive does not support the CONTINUE I/O PROCESS and TARGET TRANSFER DISABLE message for this logical unit.
- **CmdQu** is set to one to indicate that the drive supports command queuing. CmdQu is set to zero to indicate that the drive does not support command queuing.
- **SftRe** is set to zero to indicate that the target supports Hard Reset only.

² For all commands, except inquiry and request sense, if an invalid lun is specified a check condition will be returned.

- **Vendor ID** is 'IBM' padded with ASCII blanks.
- **Product ID** is specified in ASCII character. Refer **Product ID** on page16.
- **Product Revision Level** indicates the level of microcode. It indicates RAM microcode level.
- **Unit Serial Number** contains the drive serial number.
- **Clocking** 11b indicates the target supports ST (Single Transition) and DT (Double Transition) on synchronous transfer.
- **QAS** (Quick Arbitrate Supported) bit of zero indicates that the target does not support the quick arbitrate feature.
- **IUS** (Information Unit Supported) bit of zero indicates that the target does not support information unit.

8.5.1.2 Inquiry data format - CmdDt = 1

Byte	Bit							
	7	6	5	4	3	2	1	0
0	Peripheral Qualifier			Peripheral Device Type				
1	Reserved					Support		
2	Version							
3	Reserved							
4	Reserved							
5	CDB Size = m-5							
6	CDB Usage Data							
m								

Figure 58. Command support data format

- **Peripheral Qualifier** is set to zero to indicate that the LUN specified in the Identify Message is currently supported. Peripheral Qualifier is set to 011b when the LUN specified in the Identify Message is not present.³
- **Peripheral Device Type** is set to zero to indicate that the device is a Direct-Access. Peripheral Device Type is set to 1Fh when the LUN specified in the Identify Message is not present.
- **Support** indicates the type of command support. The following table defines the values and meanings of the Support field.

³ For all commands, except inquiry and request sense, if an invalid LUN is specified a check condition will be returned.

Support	Description
000b	Data about the requested SCSI operation code is not currently available.
001b	The device server does not support the tested SCSI operation code. All data after byte 1 is undefined.
010b	Reserved.
011b	The device server supports the tested SCSI operation code in conformance with the SCSI standard.
100b	Vendor-specific
101b	The device server supports the tested SCSI operation code in a vendor-specific manner.
110b	Vendor-specific
111b	Reserved

Figure 59. SUPPORT values and meanings

- **Version** indicates the level of the ANSI standard that is supported by the product. The file supports ANSI SCSI version 3.
- **CDB Size** indicates the number of bytes in the CDB for the operation, code, and size of the CDB Usage Data field in the return data.
- **CDB Usage Data** contains information about the CDB for the operation code. The first byte of the CDB Usage Data contains the operation code. All bytes except the first byte of the CDB Usage Data contain a usage map for bits in the CDB. In the usage map, the bit that is all or part of a field in the CDB is set to one, otherwise it is set to zero.

8.5.1.3 Inquiry data format - EVPD = 1 - Page Code = 00

Byte	Bit							
	7	6	5	4	3	2	1	0
0	Qualifier = 0			Peripheral Device Type = 0				
1	Page Code = 00h							
2	Reserved = 0							
3	Page Length = 03h							
4	Supported Page Code = 00h							
5	Supported Page Code = 80h							
6	Supported Page Code = 83h							

Figure 60. INQUIRY DATA - EVPD = 1 (Page Code = 00)

- **Qualifier** is set to zero to indicate that the LUN specified in the Command Block is currently supported.
- **Peripheral Device Type** is set to zero to indicate that the device is Direct Access.
- **Page Code** is set to 0, and this field contains the same value as in the page code field of the INQUIRY command descriptor block.
- **Page length** specifies the length of the following page data.
- **The Supported Page Code** field contains the Page Codes supported by the target. The list is in ascending order.

8.5.1.4 Inquiry data format - EVPD = 1 - Page Code = 80h

Byte	Bit							
	7	6	5	4	3	2	1	0
0	Qualifier = 0			Peripheral Device Type = 0				
1	Page Code = 80h							
2	Reserved = 0							
3	Page Length = 16 (10h)							
4-19	Serial Number (ASCII)							

Figure 61. INQUIRY DATA - EVPD = 1 (Page Code = 80h)

- **Qualifier** is set to zero to indicate that the LUN specified in the Command Block is currently supported.
- **Peripheral Device Type** is set to zero to indicate that the device is Direct Access.
- **Page Code** is set to 80h, and this field contains the same value as in the page code field of the INQUIRY command descriptor block.
- **Page length** is set to 16, and this field specifies the length of the following page data.
- **Serial Number** gives the drive serial number right aligned.

8.5.1.5 Inquiry data format - EVPD = 1 - Page Code = 83h

Byte	Bit								
	7	6	5	4	3	2	1	0	
0	Qualifier = 0			Peripheral Device Type = 0					
1	Page Code = 83h								
2	Reserved = 0								
3	Page Length = 12 (0Ch)								
4	Reserved = 0				Code Set = 1				
5	Reserved = 0		Association = 0		Identifier Type = 3				
6	Reserved = 0								
7	Identifier Length = 8								
8-15	(MSB)			World Wide ID					(LSB)

Figure 62. INQUIRY DATA - EVPD = 1 (Page Code = 83h)

- **Qualifier** is set to zero to indicate that the LUN specified in the Command Block is currently supported.
- **Peripheral Device Type** is set to zero to indicate that the device is Direct Access.
- **Page Code** is set to 83h, and this field contains the same value as in the page code field of the INQUIRY command descriptor block.
- **Page length** is set to 12, and this field specifies the length of the following page data.
- **Code Set** field specifies the code set used for the identifier field. The Target supports binary.
- **Association** field specifies the entity with which the identifier field is associated. The Target supports value of 0h, the Identifier field is associated with the addressed physical or logical device.
- **Identifier Type** field specifies the format and assignment authority for the identifier. The Target supports the value of 03h.
- **World Wide ID** is 64 bit unique identification for each drive. The format is: **5005076h xxxh yyb n**.

Where:

- **xxx** is 12 bit Block assignment defined for each model and manufacturing site. Refer **World Wide ID - Block assignment** on page 16.
- **yy** is 2 bit Port/Node ID select. This is 11b as for parallel SCSI interface devices.
- **n** is 22 bit drive unique serial number.

8.6 LOG SELECT (4C)

Byte	Bit							
	7	6	5	4	3	2	1	0
0	Command Code = 4Ch							
1	Reserved = 0			Reserved = 0			PCR	SP
2	PC		Reserved = 0					
3	Reserved = 0							
4								
5								
6								
7	(MSB) Parameter List Length = 0							(LSB)
8								
9	Reserved = 0					FLAG	LINK	

Figure 63. LOG SELECT (4C)

The LOG SELECT command provides a means for the initiator to clear statistical information maintained by the drive and reported via the Log Sense command.

- **PCR** The Parameter Code Reset determines whether the Log Sense parameters will be cleared and unit attention posted for all other initiators. A value of 1 indicates that the parameters be cleared, while a value of zero (except when PC = 11b) indicates that the parameters not be cleared.
- **SP** The Save Parameters bit value of zero indicates that the page parameters not be saved. A value of 1 indicates that the page parameters that are savable be saved after they have been changed.
- **PC** The Page Control field defines the type of parameters to be selected. The PC field set to 11b (and PCR is then a don't care) indicates that the Default Cumulative values are set to their default values of 0. If the PC field is set to 01b and PCR is set to 1, the Current Cumulative values are also set to their default values.
- As the drive does not support the threshold pages any other value in this field will cause the command to end with a CHECK CONDITION with a sense key of illegal request and an additional sense code of invalid field in CDB.
- **Parameter List Length** The Parameter List Length field specifies the length in bytes of the parameter list that shall be located in the DATA OUT buffer. A parameter list length zero indicates that no pages shall be transferred.

If one or more fields of the CDB are not set correctly the command will be terminated with a CHECK CONDITION status. The Sense Key shall be set to Illegal Request and the additional sense code set to Invalid Field in CDB.

The Log Select command will reset the counter variables to their default values of zero. These variables are listed in the Log Sense command.

To indicate that parameters have changed, the target generates a unit attention condition for all initiators except the one that issued the Log Select command.

8.7 LOG SENSE (4D)

Byte	Bit							
	7	6	5	4	3	2	1	0
0	Command Code = 4Dh							
1	Reserved = 0			Reserved = 0			PPC= 0	SP
2	PC		Page Code					
3 4	Reserved = 0							
5 6	(MSB)		Parameter Pointer = 0				(LSB)	
7 8	(MSB)		Allocation Length				(LSB)	
9	Reserved = 0					FLAG	LINK	

Figure 64. LOG SENSE (4D)

The LOG SENSE command allows the initiator to retrieve the statistical data regarding the drive.

- **PPC** (Parameter Pointer Control) bit must be set to zero. This specifies that the drive start transferring data starting from the field specified in the parameter pointer field for the number of bytes specified by the allocation length. If the PPC bit is set to 1, CHECK CONDITION status is returned with a Sense Key of Illegal Request and additional sense code of Invalid Field in CDB.
- **SP** (Save Parameters) bit set to 0 specifies that the drive does not save any log parameters. If it is set to 1, all page parameters that are savable (those pages denoted by a DS = 0 in the parameter header control byte) are saved.
- **PC** (Page Control) field defines the type of parameters to be selected. This field must be set to 01b to specify the current cumulative values or 11b to specify the default cumulative values. As the drive does not support the threshold pages any other value in this field will cause the command to end with a CHECK CONDITION with a sense key of illegal request and an additional sense code of invalid field in CDB.
- **Page Code** field identifies which page is being requested. This field must be set to the values indicated in Page 0. If the Page Code value is invalid a CHECK CONDITION status is returned with a Sense Key of Illegal Request and additional sense code of Invalid Field in CDB.
- **Parameter Pointer Field** specifies the beginning field for the transfer. This field must be set to 0000h. If the Parameter Pointer Field is not zero a CHECK CONDITION status is returned with a Sense Key of Illegal Request and additional sense code of Invalid Field in CDB.
- **Allocation Length** field specifies the maximum number of bytes the Initiator has allocated for returned Log Sense Data. No bytes are transferred if the length is zero. This condition is not considered an error. The target terminates the Data In phase when all available Log Sense data has been transferred or when the number of bytes equals the allocation length, whichever is less.

8.7.1 Log Page parameters

Each log page begins with a four-byte page header followed by zero or more variable-length log parameters.

- **Page Header**

Page Code field identifies which log page is being transferred.

The Page Length field specifies the length in bytes of the following log parameters.

- **Log Parameters**

Each log parameter begins with a four-byte parameter header followed by one or more bytes of parameter value data.

The Parameter Code field identifies which log parameter is being transferred for that log page.

The Parameter Control field, the 3rd byte of each parameter header, contains several fields.

- **DU** The Disable Update bit is set to 0 which indicates that the drive updates the log parameter value to reflect events that should be noted by that parameter.
- **DS** The Disable Save bit is set to 1 to indicate the parameter is non-savable and is set to 0 to indicate that the parameter is savable.
- **TSD** The Target Save Disable bit is set to zero which indicates that the drive provides a target defined method for saving log parameters.
- **ETC** The enable Threshold Comparison bit is set to 0 which indicates the drive does not perform comparisons between cumulative and any threshold values.
- **TMC** The Threshold Met Criteria field is not valid because this drive does not perform threshold comparisons. This field is set to 0.
- **LBIN** The List Binary bit is set to 1 for vendor unique pages whose parameters lists are in binary format, not ASCII. This bit is reserved and set to 0 for all other pages.
- **LP** The List Parameter bit is set to 0 for parameters that are data counters. The LP bit is set to 1 for parameters that are lists.

8.7.2 Log Sense Page 0

Page 0 indicates the supported log sense pages. This page is used to determine which additional pages can be requested by an Initiator.

Byte	Bit							
	7	6	5	4	3	2	1	0
0	Reserved		Page code = 0					
1	Reserved							
2-3	Page Length = 000Ah (Number of Pages Supported)							
4	First supported page 0h							
5	Second supported page 2h							
6	Third supported page 3h							
7	Fourth supported page 5h							
8	Fifth supported page 6h							
9	Sixth supported page Dh							
10	Seventh supported page Eh							
11	Eighth supported page Fh							
12	Ninth supported page 10h							
13	Tenth supported page 2Fh							

Figure 65. Log Sense Page 0

8.7.3 Log Sense Page 2

This page contains counters for write errors.

Byte	Bit							
	7	6	5	4	3	2	1	0
0	Reserved		Page code = 02h					
1	Reserved							
2-3	PageLength = 54h							
4-5	Parameter Code = 00h							
6	DU = 0	DS = 0	TSD = 0	ETC = 0	TMC = 0		LBIN = 0	LP = 0
7	Parameter Length = 08h							
8-15	Errors recovered without delay = 0							
16-17	Parameter Code = 01h							
18	DU = 0	DS = 0	TSD = 0	ETC = 0	TMC = 0		LBIN = 0	LP = 0
19	Parameter Length = 08h							
20-27	Count of LBA's with write fault errors							
28-29	Parameter Code = 02h							
30	DU = 0	DS = 0	TSD = 0	ETC = 0	TMC = 0		LBIN = 0	LP = 0
31	Parameter Length = 08h							
32-39	Count of LBA's with id type errors							
40-41	Parameter Code = 03h							
42	DU = 0	DS = 0	TSD = 0	ETC = 0	TMC = 0		LBIN = 0	LP = 0
43	Parameter Length = 08h							
44-51	Total errors recovered							
52-53	Parameter Code = 04h							
54	DU = 0	DS = 0	TSD = 0	ETC = 0	TMC = 0		LBIN = 0	LP = 0
55	Parameter Length = 08h							
56-63	Times recovery invoked							

Figure continued on next page

Figure 66. Log Sense Page 2

Byte	Bit							
	7	6	5	4	3	2	1	0
64-65	Parameter Code = 05h							
66	DU = 0	DS = 0	TSD = 0	ETC = 0	TMC = 0		LBIN = 0	LP = 0
67	Parameter Length = 08h							
68-75	Total bytes written							
76-77	Parameter Code = 06h							
78	DU = 0	DS = 0	TSD = 0	ETC = 0	TMC = 0		LBIN = 0	LP = 0
79	Parameter Length = 08h							
80-87	Count of LBA's with hard errors							

Figure 64 concluded.

8.7.4 Log Sense Page 3

This page contains counters for read errors

Byte	Bit							
	7	6	5	4	3	2	1	0
0	Reserved		Page code = 03h					
1	Reserved							
2-3	PageLength = 54h							
4-5	Parameter Code = 00h							
6	DU = 0	DS = 0	TSD = 0	ETC = 0	TMC = 0		LBIN = 0	LP = 0
7	Parameter Length = 08h							
8-15	Errors recovered without delay = 0							
16-17	Parameter Code = 01h							
18	DU = 0	DS = 0	TSD = 0	ETC = 0	TMC = 0		LBIN = 0	LP = 0
19	Parameter Length = 08h							
20-27	Count of LBA's with ECC detected errors							
28-29	Parameter Code = 02h							
30	DU = 0	DS = 0	TSD = 0	ETC = 0	TMC = 0		LBIN = 0	LP = 0
31	Parameter Length = 08h							
32-39	Count of LBA's with id type errors							
40-41	Parameter Code = 03h							
42	DU = 0	DS = 0	TSD = 0	ETC = 0	TMC = 0		LBIN = 0	LP = 0
43	Parameter Length = 08h							
44-51	Total errors recovered							
52-53	Parameter Code = 04h							
54	DU = 0	DS = 0	TSD = 0	ETC = 0	TMC = 0		LBIN = 0	LP = 0
55	Parameter Length = 08h							
56-63	Times recovery invoked							
64-65	Parameter Code = 05h							

Figure continued on next page

Figure 67. Log Sense Page 3

Byte	Bit							
	7	6	5	4	3	2	1	0
66	DU = 0	DS = 0	TSD = 0	ETC = 0	TMC = 0		LBIN = 0	LP = 0
67	Parameter Length = 08h							
68-75	Total bytes written							
76-77	Parameter Code = 06h							
78	DU = 0	DS = 0	TSD = 0	ETC = 0	TMC = 0		LBIN = 0	LP = 0
79	Parameter Length = 08h							
80-87	Count of LBA's with hard errors							

Figure 65. concluded

The drive will attempt to read data after a seek before the head has fully settled on track. This is done to aid performance. However as a result there is a high incidence of error recovery invoked which normally uses ECC or a retry to recover the data. As a consequence of this an error recovered by a single retry is not reported by the error counters.

Additionally the drive does not report data recovered by ECC on the fly as it is not possible to distinguish between ECC errors caused by reading before settling and other causes.

8.7.5 Log Sense Page 5

This page contains counters for verify errors

Byte	Bit							
	7	6	5	4	3	2	1	0
0	Reserved		Page code = 05h					
1	Reserved							
2-3	PageLength = 54h							
4-5	Parameter Code = 00h							
6	DU = 0	DS = 0	TSD = 0	ETC = 0	TMC = 0		LBIN = 0	LP = 0
7	Parameter Length = 08h							
8-15	Errors recovered without delay = 0							
16-17	Parameter Code = 01h							
18	DU = 0	DS = 0	TSD = 0	ETC = 0	TMC = 0		LBIN = 0	LP = 0
19	Parameter Length = 08h							
20-27	Count of LBA's with ECC detected errors							
28-29	Parameter Code = 02h							
30	DU = 0	DS = 0	TSD = 0	ETC = 0	TMC = 0		LBIN = 0	LP = 0
31	Parameter Length = 08h							
32-39	Count of LBA's with id type errors							
40-41	Parameter Code = 03h							
42	DU = 0	DS = 0	TSD = 0	ETC = 0	TMC = 0		LBIN = 0	LP = 0
43	Parameter Length = 08h							
44-51	Total errors recovered							
52-53	Parameter Code = 04h							
54	DU = 0	DS = 0	TSD = 0	ETC = 0	TMC = 0		LBIN = 0	LP = 0
55	Parameter Length = 08h							
56-63	Times recovery invoked							
64-65	Parameter Code = 05h							

Figure continued on next page

Figure 68. Log Sense Page 5

Byte	Bit							
	7	6	5	4	3	2	1	0
66	DU = 0	DS = 0	TSD = 0	ETC = 0	TMC = 0		LBIN = 0	LP = 0
67	Parameter Length = 08h							
68-75	Total Bytes Verified							
76-77	Parameter Code = 06h							
78	DU = 0	DS = 0		TSD = 0	TMC = 0		LBIN = 0	LP = 0
79	Parameter Length = 08h							
80-87	Count of LBA's with hard errors							

Figure 66. concluded

In order to aid performance, the drive will attempt to read data after a seek before the head has fully settled on track. However there is a high incidence of error recovery invoked as a result which normally uses ECC or a retry to recover the data. As a consequence of this an error recovered by a single retry is not reported by the error counters.

Additionally the drive does not report data recovered by ECC on the fly as it is not possible to distinguish between ECC errors caused by reading before settling and other causes.

8.7.6 Log Sense Page 6

This page contains counters for non-medium errors. This includes seek errors and other hardware type failures.

Byte	Bit							
	7	6	5	4	3	2	1	0
0	Reserved		Page code = 06h					
1	Reserved							
2-3	PageLength = 0Ch							
4-5	Parameter Code = 00h							
6	DU = 0	DS = 0	TSD = 0	ETC = 0	TMC = 0		LBIN = 0	LP = 0
7	Parameter Length = 08h							
8-15	Error count							

Figure 69. Log Sense Page 6

8.7.7 Log Sense Page D

This page contains temperature information.

Byte	Bit							
	7	6	5	4	3	2	1	0
0	Reserved		Page code = 0Dh					
1	Reserved							
2-3	PageLength = 0Ch							
4-5	Parameter Code = 0000h							
6	DU = 0	DS = 1	TSD = 0	ETC = 0	TMC = 0		LBIN = 1	LP = 0
7	Parameter Length = 02h							
8	Reserved							
9	Temperature (degrees Celsius)							
10-11	Parameter Code 0001h							
12	DU = 0	DS = 1	TSD = 0	ETC = 0	TMC = 0		LBIN = 1	LP = 0
13	Parameter Length = 02h							
14	Reserved							
15	Reference Temperature (degrees Celsius)							

Figure 70. Log Sense Page D

8.7.8 Log Sense Page E

This page contains the start-stop cycle information.

Byte	Bit							
	7	6	5	4	3	2	1	0
0	Reserved		Page code = 0Eh					
1	Reserved							
2-3	PageLength = 24h							
4-5	Parameter Code = 0001h							
6	DU = 0	DS = 1	TSD = 0	ETC = 0	TMC = 0		LBIN = 0	LP = 1
7	Parameter Length = 06h							
8-11	Year of Manufacture (4 ASCII characters)							
12-13	Week of Manufacture (2 ASCII characters)							
14-15	Parameter Code 0002h							
16	DU = 0	DS = 1	TSD = 0	ETC = 0	TMC = 0		LBIN = 0	LP = 1
17	Parameter Length = 06h							
18-21	Accounting Date Year (4 ASCII characters)							
22-23	Accounting Date Week (2 ASCII characters)							
24-25	Parameter Code 0003h							
26	DU = 0	DS = 1	TSD = 0	ETC = 0	TMC = 0		LBIN = 1	LP = 1
27	Parameter Length = 04h							
28-31	Specified cycle count over device lifetime							
32-33	Parameter Code 0004h							
34	DU = 0	DS = 1	TSD = 0	ETC = 0	TMC = 0		LBIN = 1	LP = 1
35	Parameter Length = 04h							
36-39	Accumulated start-stop cycles (4 byte binary number)							

Figure 71. Log Sense Page E

The week and year that the device was manufactured shall be set in the parameter field defined by parameter code 0001h. The date of manufacture cannot be saved using the LOG SELECT command. The data is expected in numeric ASCII characters (30-39h) in the form YYYYWW. The accounting date specified by parameter code 0002h is a parameter that can be saved using the LOG SELECT command.

8.7.9 Log Sense Page F

This page contains the Application Client Log.

Byte	Bit							
	7	6	5	4	3	2	1	0
0	Reserved		Page code = 0Fh					
1	Reserved							
2-3	Page length = 4000h							
	Application client log parameter							
4-	First application client log parameter							
-4003h	Last application client log parameter							

The following table describes the application client log parameter structure.

Byte	Bit							
	7	6	5	4	3	2	1	0
0-1	Parameter code							
2	DU = 0	DS = 1	TSD = 0	ETC = 0	TMC = 0		LBIN = 1	LP = 1
3	Parameter length = FCh							
4-	First parameter byte							
255	Last parameter byte							

Figure 70. Log Sense Page F Application Client Log

Parameter code 0000h through 003Fh are supported.

The values stored in the parameter bytes represent data sent to the device in a previous LOG SELECT command.

8.7.10 Log Sense Page 10

This page contains Self-test results.

Byte	Bit							
	7	6	5	4	3	2	1	0
0	Reserved		Page code = 10h					
1	Reserved							
2-3	PageLength = 190h							
	Self-test results log parameters							
4-	First self-test results log parameter							
-403h	Last self-test results log parameter							

The results of the twenty most recent self-tests are stored in this Log page. The following table describes the self-test results log parameter structure.

Byte	Bit							
	7	6	5	4	3	2	1	0
0-1	Parameter code							
2	DU = 0	DS = 0	TSD = 0	ETC = 0	TMC = 0		LBIN = 1	LP = 1
3	Parameter Length = 10h							
4	Function Code		RSVD	Self-Test Results Value				
5	Extended Segment Number							
6-7	Timestamp							
8-15	LBA of First Failure							
16	Reserved			Sense Key				
17	Additional Sense Code							
18	Additional Sense Code Qualifier							
19	Vendor specific							

Figure 71. Log Sense Page 10 Self-Test Results

- **Parameter Code** identifies the log parameter for the log page. The parameter Code field for the results of the most recent test will be 0001h. The parameter for the next most recent will be 0002h.
- **Function Code** contains the content of the Function Code field in the SEND DIAGNOSTIC command that initiated this self-test.
- **Self-Test Results Value** is described in the table below.

Value	Description
0h	The self-test routine completed without error.
1h	The background self-test routine was aborted by the initiator using a SEND DIAGNOSTICS command with the Abort Background self-test function.
2h	The self-test routine was aborted by the application client by a Task Management function of a reset.
3h	An unknown error occurred while the target was executing the self-test routine and the target was unable to complete the self-test routine.
4h	The self-test completed with a test element that failed and it is not known which test element failed.
5h	The first segment of the self-test failed.
6h	The second segment of the self-test failed.
7h	The third or greater segment of the self-test failed (see the Extended segment number field).
8h-Eh	Reserved.
Fh	The self-test is in progress.

Figure 72. Log Sense Page 10 Self-Test Results

- **Extended Segment Number** This field will be used to identify the number of the segment that failed during self-test. If no segment failed, this field will be 00h.
- **Timestamp** This field contains the total accumulated power-on hours of the target at the time the self-test completed.
- **LBA of first failure** This field contains the LBA of the first logical block address where a self-test error occurred. If no errors occurred during the self-test or the error is not related to a Logical Block Address then the field will be FFFFFFFFFFFFFFFFh.
- **Sense Key, Additional Sense Code and Additional Sense Code Qualifier** These fields will contain the additional information relating to the error or exception conditions during self-test.

Extended Segment Number	Test
0h	NA
1h	Spin Check
2h	Write/Read/Compare
3h	ECC Test
4h	Random Seek
5h	Read Scan

Figure 73. Log Sense Page 10 Extended Segment Number

8.7.11 Log Sense Page 2F

This page contains SMART Status and Temperature Reading.

Byte	Bit							
	7	6	5	4	3	2	1	0
0	Reserved		Page code = 2Fh					
1	Reserved							
2-3	PageLength = 8							
4-5	Parameter Code = 0000h							
6	DU = 0	DS = 0	TSD = 0	ETC = 0	TMC = 0		LBIN = 0	LP = 0
7	Parameter Length = 04h							
8	SMART Sense Code Byte							
9	SMART Sense Qualifier							
10	Most Recent Temperature Reading							
11	Vendor HDA Temperature Trip Point							

Figure 74. Log Sense Page 2F

8.8 MODE SENSE (1A)

Byte	Bit							
	7	6	5	4	3	2	1	0
0	Command Code = 1Ah							
1	Reserved		RSVD	DBD	Reserved = 0			
2	PCF		Page Code					
3	Reserved = 0							
4	Allocation Length							
5	VU = 0		Reserved = 0			FLAG	LINK	

Figure 75. MODE SENSE (1A)

The MODE SENSE (1A) command provides a means for the drive to report various device parameters to the initiator. It is the complement to the MODE SELECT command.

If the **DBD** (Disable Block Descriptor) bit is zero, the target will return the Block Descriptor. If the DBD bit is set to 1, the target will not return the Block Descriptor.

Allocation Length indicates the maximum number of bytes which the initiator has set aside for the DATA IN phase. A value of zero is not considered an error. If the allocation length is smaller than the amount available, that portion of the data up to the allocation length will be sent. This may result in only a portion of a multi-byte field being sent.

Page Control Field: PCF (Page Control Field) defines the type of Page Parameter values to be returned.

PCF Meaning

0 0 Report current values. The drive returns the current values under which the logical unit is presently configured for the page code specified. The current values returned are

1. The parameters set in the last successful MODE SELECT command.
2. The saved values if a MODE SELECT command has not been executed since the last power-on, hard RESET condition, or BUS DEVICE RESET message.

Note: The drive will not process the Mode Select command until the completion of spin-up. Therefore, the initiator cannot modify the current values prior to the saved values being read in.

0 1 Report changeable value. The drive returns the changeable values for the page code specified. The page requested is returned containing information that indicates which fields are changeable. All bits of parameters that are changeable shall be set to one. Parameters that are *defined by the drive* shall be set to zero. If any part of a field is changeable, all bits in that field shall be set to one.

Note: For a value field such as the buffer ratios of page 2 the bit field will not indicate the range of supported values but rather that the field is supported.

1 0 Report default value. The drive returns the default values for the page code specified. The parameters not supported by the drive are set to zero.

1 1 Report saved value. The drive returns the saved value for the page code specified.

Saved values are one of following:

- the values saved as a result of MODE SELECT command
- identical to the default values
- zero when the parameters are not supported

The Page Length byte value of each page returned by the drive indicates up to which fields are supported on that page.

Page Code: This field specifies which page or pages to return. Page code usage is defined in the figure below.

Page Code	Description
00h - 1Ch 3Fh	Return specific page Return all available pages

Figure 76. Page Code Usage

8.8.1 Mode Parameter List

The mode parameter list contains a header followed by zero or more block descriptors followed by zero or more variable length pages.

8.8.1.1 Header

The six-byte command descriptor block header is defined below.

Mode parameter header (6)

Byte	Bit							
	7	6	5	4	3	2	1	0
0	Mode Data Length							
1	Medium Type = 0							
2	WP	Reserved = 0						
3	Block Descriptor Length (= 0 or 8)							

Figure 77. Mode parameter header (6)

The ten-byte command descriptor block header is defined below.

Mode parameter header (10)

Byte	Bit							
	7	6	5	4	3	2	1	0
0 1	(MSB) Mode Data Length							(LSB)
2	Medium Type = 0							
3	WP	Reserved = 0						
4 5	Reserved = 0							
6 7	(MSB) Block Descriptor Length (= 0 or 8)							(LSB)

Figure 78. Mode parameter header (10)

- **Mode Data Length.** When using the MODE SENSE command, the mode data length field specifies the length in bytes of the following data that is available to be transferred. The mode data length does not include the length byte itself. When using the MODE SELECT command, this field is reserved.
- **Medium Type** field is always set to zero in the drive (Default Medium Type).
- **WP.** When used with the MODE SELECT command, the Write Protect (WP) bit is reserved.
When used with the MODE SENSE command, a Write Protect (WP) bit of zero indicates that the medium is write enabled.
- **Block Descriptor Length** specifies the length in bytes of the block descriptors.
When used with the MODE SELECT command, zero or eight is supported by the drive.
When used with the MODE SENSE command, the drive returns eight to indicate that only a single block descriptor is available.

8.8.1.2 Block Descriptor

Byte 0	Number of Blocks (MSB)
Byte 1	
Byte 2	
Byte 3	
Byte 4	Density code = 0
Byte 5	Block Length
Byte 6	
Byte 7	

Figure 79. MODE Parameter Block Descriptor

The Block descriptor provides formatting information about the Number of Blocks (user addressable) to format at the specified Block Length.

- **Number of Blocks**

When used with the MODE SELECT command, the **Number of Blocks** field must be

- Zero to indicate not to change available blocks
- 0xFFFFFFFF to indicate all available blocks
- The exact number of blocks in the data area of the drive, which can be obtained with the MODE SENSE
- The number of blocks less than exact one, in order to **CLIP** the number of blocks

Any other value is invalid and causes the command to fail with CHECK CONDITION status.

When used with the MODE SENSE command, the field contain exact number of blocks.

- **Block Length**

When used with the MODE SELECT command, the **Block length** field must contain the value from 512 to 528 (2 bytes step) or zero. Otherwise the drive will terminate the command with CHECK CONDITION status.

A Format Unit command is required to cause these parameters to become current only if the block length parameter is different from the current block length.

When used with the MODE SENSE command, the field is dependent on how the media is currently formatted.

8.8.1.3 Page Descriptor

Byte 0	PS	RSVD=0	Page Code
Byte 1	Page Length		
Byte 2-n	Mode Parameters		

Figure 80. MODE Parameter Page Format

Each mode page contains a page code, a page length, and a set of mode parameters.

When using the MODE SENSE command, a Parameter Savable (PS) bit of one indicates that the mode page can be saved by the drive in the reserved area of the drive. A PS bit of zero indicates that the supported parameters cannot be saved. When using the MODE SELECT command, the PS bit is reserved (zero).

The drive supports the following mode page code:

Page	Description	PS
00	Vendor Unique Parameters	1
01	Read-Write Error Recovery Parameters	1
02	Disconnect/Reconnect Control Parameters	1
03	Format Device Parameters	0
04	Rigid Disk Geometry Parameters	0
07	Verify Error Recovery Parameters	1
08	Caching Parameters	1
0A	Control Mode Page	1
0C	Notch Parameters	1
19	Port Control Page	1
1A	Power Control Parameters	1
1C	Informational Exceptions Control	1

Figure 81. Page Code Usage

The page length field specifies the length in bytes of the mode parameters that follow. If the initiator does not set this value to the value that is returned for the page by the MODE SENSE command, the drive will terminate the command with CHECK CONDITION status.

8.8.2 Mode Page 0 (Vendor Unique Parameters)

Byte	Bit								Default
	7	6	5	4	3	2	1	0	
0	PS	RSVD=0	Page Code = 00h						80h
1	Page Length = 0Eh								0Eh
2	QPE	Ignored		UAI	MRG	Ignored		ARHES	51h
3	ASDPE	Ignored	CMDAC	Ignored			RRNDE	CPE	21h
4	Ignored								00h
5	Ignored			FDD	Ignored		CAEN	Ignored	12h
6	IGRA	AVERP	Ignored				EQuiet	Ignored	00h
7	Ignored								00h
8	Ignore	ADC	Ignored		LED Mode				40h
9	Temperature								00h
10	Command Aging Limit (Hi byte)								00h
11	Command Aging Limit (Low byte)								30h
12	QPE Read Threshold								0Ah
13	QPE Write Threshold								0Ah
14	DRRT	Ignored			FFMT	Ignored			00h
15	Ignored		FCERT	Ignored			IRT	IVR	00h

Figure 82. Vendor Unique Parameters - Page 0

Fields marked in the table as 'Ignored' are not used or checked by the drive. They will be initialized to zero but may be set as desired for compatibility with older drives.

- **QPE** (Qualify Post Error) bit allows the Initiator to inhibit the reporting of recovered data errors which are recovered under Data Recovery Procedure (DRP) step. A QPE bit of zero causes the Target to report all recovered data errors. A QPE bit of one causes the Target to report only those recovered data errors which exceed the QPE threshold.
- **UAI** (Unit Attention Inhibit) bit is not used during normal operation when the UAI jumper is removed from the drive. It may however be changed by the user with no effects. If the UAI jumper is added to the drive, then this bit controls the generation of unit attention conditions.
- **MRG** (Merge G-List into P-List) bit is set to 1 for merging the Grown Defect List (G-List) entries into the Primary Defect List (P-List) during Format Unit command.
- **ARHES** (Automatic Reassign Hard Error Sites) bit of one indicates that the drive will automatically reassign a hard read error. When the ARHES bit is active, the LBA with an unrecovered read error is internally registered as a reassign candidate and, when the write command is received to the failing LBA, the data is written and verified if the error still exists. If the error still occurs on the failing LBA, it will be reassigned. If the error is cleared, the Target will remove the reassign candidate internally for the previously failing LBA. ARHES bit of zero indicates the drive will not automatically recover a

hard read error. ARRE and AWRE bits in Mode Page 1 do not affect ARHES operation and ARHES works independently.

- **ASDPE** (Additional Save Data Pointer Enable) bit is used to control the sending of additional save data pointers messages. When set it will cause a save data pointers message to be sent on every disconnection. This bit is only used by the Target after the Default Mode parameter values are overridden with the Saved values which are read from the Reserved Area of the media as a part of the motor startup sequence. Before the Saved values are read from the Reserved Area of the media, the Save Data Pointer message is always sent to the Initiator prior to disconnection. When not set, a save data pointers message is sent only if the current connection contained a data phase and a further data phase will be required to complete the command.
- **CMDAC** (Command Active) bit in conjunction with **LED Mode** bits determines if an LED on the drive is activated while commands are active. If CMDAC bit is one and LED Mode bits are zero, an LED driver is active when a command is queued or executed.
- **RRNDE** (Report Recovered Non Data Errors) bit controls the reporting of recovered Non Data Errors when the PER bit is set. If RRNDE is set, recovered Non Data Errors are reported. If the RRNDE bit is not set, then recovered Non Data Errors are not reported.
- **CPE** (Concurrent Processing Enable) bit is allowed to be modified by the initiator for host system device driver compatibility. Read(6), Read extend(10), Write(6), Write extend(10), and untagged and unlinked Request Sense or Inquiry can be executed concurrently in both CPE bit set to 0 and 1.
- **FDD** (Format Degraded Disable) bit of 1 prevents the drive from reporting Format degraded. An FDD bit of 0 indicates that Format degraded is reported for the Test Unit Ready Command and causes media access commands (i.e. Read, Write) to report a media error if degraded.
- **CAEN** When set this bit causes the Command Age Limit timer to be used to avoid commands waiting in the command queue for an indefinite period. When commands have been in the queue for a period of time greater than the timer limit they will be reordered to be executed on a first come first served basis. When this bit is reset, commands are always executed based on the queue reordering rules.
- **IGRA** (Ignore Reassigned LBA) bit is set to 1 for preventing the drive from reassigned processing against reassigned LBA when RC bit (Mode Page 1 byte 2 bit 4) is active. The main purpose of this bit is to avoid undesirable read processing time delay due to reassigned LBA processing for continuous data availability requirements such as Audio Visual application. IGRA bit set to 0 specifies that the drive shall process reassigned LBA even if RC bit is active.
- **AVERP** (AV ERP Mode) bit is set to one in order to specify maximum retry counts during DRP and command execution time limit. When AVERP bit is set to one, the maximum retry counts for read and write operations are specified by Read Retry Count (Mode Page 1 Byte 3) and Write Retry Count (Mode Page 1 Byte 8) respectively. Recovery Time Limit (Mode Page 1 Byte 10 and 11) is effective to limit the command execution time. AVERP bit is set to zero to ignore the Recovery Time Limit value and to specify that the drive shall process DRP up to the default maximum retry count when Read Retry Count and Write Retry Count are set to a non-zero value.
- **EQuiet** (Enable Quiet), when set, enables Quiet Seek Mode for better acoustic performance.
- **ADC** (Adaptive Cache Enable), when set, allows the drive to modify the read-ahead caching algorithm, ignoring parameters in Page 8. The adaptation is based on analyzing the most recent command history and the current contents of the cache buffers.

- **LED Mode** is designed to control the operation of a drive LED driver.

- LED Mode = 0000b

The CMDAC bit controls the LED.

CMDAC = 1 (Command Active)

CMDAC = 0 (Motor Active)

- LED Mode = 0001b (Motor Active)

When the motor is spinning, the LED is high.

- LED Mode = 0010b (Command Active).

When there is a command active or in the queue, the LED is high.

- **Temperature Threshold** specifies the threshold value in degrees Celsius for the thermal sensor warning message. A value of 0 selects the default value (85 degrees Celsius).
- **Command Aging Limit** This value is used to control the maximum time a command should wait in the command queue when the CAEN bit is set. Each unit of this timer is 50 ms.
- **QPE Read Threshold** specifies the error reporting threshold for read operations when the QPE bit is set to one.
- **QPE Write Threshold** specifies the error reporting threshold for write operations when the QPE bit is set to one.
- **DRRT** (Disable Restore Reassign Target) bit disables the reading and restoration of the target LBA during a Reassign Blocks command. If the DRRT bit is zero, the reassign command attempts to restore the target LBA's data. If the data cannot be restored, the target LBA is reassigned and written with a data pattern of all 00's. If the DRRT bit is one, no attempt is made to restore the target LBA.
- **FFMT** (Fast Format enable) bit allows the formatting of the drive without any writes to the customer media. All format operations are allowed including changing block sizes and manipulating defects. The drive will operate normally after a fast format with the following caveat: since no data is written to any customer data blocks as a result of a Fast Format operation, there is a possibility that a read attempt to any particular block (without having previously written to that block) will result in an unrecoverable data error. This will most likely happen if the block size is changed as every LBA will contain data of an incorrect length and apparently an incorrect starting point. It is also possible to generate an uncorrectable data error without changing block sizes if the defect list is shortened and previously bad blocks become visible in the customer address space. Of course ALL DATA ON THE DRIVE WILL BE LOST as the result of any format operation and so any attempt to read blocks which have not been written to will result in unpredictable behavior.
- **FCERT** (Format Certification) bit determines whether the certification step will be performed during a Format Unit command. A FCERT bit set to 0 disables certification. A FCERT bit set to 1 enables the certification step.
- **IRT** (Integration Reassign Threshold) bit determines the threshold used to recommend reassignment or initiate auto-reassign. When IRT is disabled with a value set to 0, the thresholds used to determine when a sector should be reassigned and either recommended or auto-reassigned are set to values optimized for end user environments, depending upon state of the ARRE and AWRE bits. When enabled by setting to 1, thresholds optimized for integrating the drive into a system to minimize end- user field failures is used.
- **IVR** (Integration Verify Recovery) bit determines the maximum number of steps attempted during a Verify Recovery Procedure (VRP). When disabled with a value set to 0, all of the steps are attempted, if required. When enabled by setting to 1, a maximum number of steps optimized for integrating the drive into a system to minimize end-user field failures is used.

8.8.3 Mode Page 1 (Read/Write Error Recovery Parameters)

Byte	Bit								Default	
	7	6	5	4	3	2	1	0		
0	PS	RSVD=0	Page Code = 01h							81h
1	Page Length = 0Ah								0Ah	
2	AWRE	ARRE	TB	RC	EER=0	PER	DTE	DCR	C0h	
3	Read Retry Count								01h	
4	Correction Span								00h	
5	Head Offset Count (Ignored)								00h	
6	Data Strobe Offset Count (Ignored)								00h	
7	Reserved								00h	
8	Write Retry Count								01h	
9	Reserved								00h	
10	(MSB)	Recovery Time Limit							00h	
11								(LSB)	00h	

Figure 83. Mode Page 1 (Vendor Unique Parameters)

The Read-Write recovery parameters that will be used during any command that performs a read or write operation to the medium are as follows:

- **AWRE**, an Automatic Write Reallocation Enabled bit, set to zero indicates that the drive shall not perform automatic reallocation of defective data blocks during write operations. An AWRE bit set to one indicates that the drive shall perform automatic reallocation of defective data blocks during write operations.
- **ARRE**, an Automatic Read Reallocation Enabled bit, set to zero indicates that the drive shall not perform automatic reallocation of defective data blocks during read operations. A ARRE bit set to one indicates that the drive shall perform automatic reallocation of defective data blocks during read operations.
- **TB**, a Transfer Block bit, set to one indicates that a data block that is not recovered within the recovery limits specified shall be transferred to the initiator before CHECK CONDITION status is returned. A TB bit set to zero indicates that such a data block shall not be transferred to the initiator. Data blocks that can be recovered within the recovery limits are always transferred regardless of the value of the bit.
- **RC**, a Read Continuous bit, set to one requests the Target to transfer the entire requested length of data without adding delays which would increase or ensure data integrity. This implies that the Target may send erroneous data. This bit has priority over all other error control bits (PER, DTE, DCR, TB). RC set to zero indicates normal interpretation of PER, DTE, DCR, and TB values. The RC bit setting is used by the Target when reporting errors associated with the transfer of the Initiator's data for the following commands:
 - Read(6)
 - Read(10)

For all other commands, the RC bit setting is unused and treated as zero.

Note: The Target implementation of the RC option is to disable error detection of the data fields but continue normal error detection and recovery for errors occurring in the servo field. If a servo field failure occurs, normal DRP could result in considerable recovery action, including proceeding through all levels of DRP.

- **EER**, an Enable Early Recovery bit, **must be set to zero**, indicating that the drive shall use an error recovery procedure that minimizes the risk of misdetection or miscorrection during the data transfer. Data shall not be fabricated.
- **PER**, a Post Error bit, is set to one to indicate that the drive reports recovered errors.
- **DTE**, a Disable Transfer on Error bit, is set to one to indicate that the drive terminates the DATA phase upon detection of a recovered error .
- **DCR**, a Disable Correction bit, is set to one to indicate that Error Correction Code is not used for data error recovery. A DCR bit of zero indicates that ECC is applied to recover the data.
- **Read Retry Count** sets a limit on the amount of DRP passes in which the Target attempts to recover read errors. A value of zero disables all data recovery procedures. When AVERP bit (Mode Page 0 Byte 6 Bit 6) is zero, a value of non-zero in Read Retry Count enables all steps of DRP. When AVERP bit is one, the number in Read Retry Count sets the maximum retry count of DRP.
- **Correction Span** field specifies the size in bits of the largest data error burst for which data error correction may be attempted. Any value may be set into this field including zero. The drive will always use its default correction capabilities.
- **Head Offset Count** is not supported by the drive.

Note: Head Offset is implemented in the read error recovery routine. The user can not modify the offset value.

- **Write Retry Count** sets a limit on the amount of DRP passes in which the Target attempts to recover write errors. A value of zero disables all data recovery procedures. When AVERP bit (Mode Page 0 Byte 6 Bit 6) is zero, a value of non-zero in Write Retry Count enables all steps of DRP. When AVERP bit is one, the number in Write Retry Count sets the maximum retry count of DRP.
- **Recovery Time Limit** indicates the period in 1 millisecond increments for the maximum command execution time. The value must be from 40 msec to 65535 msec (65.5seconds). If a command is not able to be completed within the limit, a check condition will be returned when following mode page parameters are set.
 - ARHES = 0
 - AWRE = 0
 - ARRE = 0
 - WCE = 0

The following summarizes valid modes of operation. If an illegal mode is set, the mode select command will complete successfully but the action of the drive when an error occurs is undefined.

PER	DTE	DCR	TB	DESCRIPTION
0	0	0	0	Retries and Error Correction are attempted. Recovered and/or corrected data (if any) are transferred with no CHECK CONDITION status at the end of the transfer. no err The transfer length is exhausted. soft err The transfer length is exhausted. Transferred data includes blocks containing recovered errors. hard err Data transfer stops when an unrecoverable error is encountered. The unrecoverable block is not transferred to the initiator. The drive then creates the CHECK CONDITION status with the appropriate Sense Key.
0	0	0	1	Retries and Error Correction are attempted. Recovered and/or corrected data (if any) are transferred with no CHECK CONDITION status at the end of the transfer. no err The transfer length is exhausted. soft err The transfer length is exhausted. Transferred data includes blocks containing recovered errors. hard err Data transfer stops when an unrecoverable error is encountered. The unrecoverable block is transferred to the initiator. The drive then creates the CHECK CONDITION status with the appropriate Sense Key.
0	0	1	0	Retries are attempted but no error correction (ECC) is applied. Recovered data (if any) are transferred with no CHECK CONDITION status at the end of the transfer. no err The transfer length is exhausted. soft err The transfer length is exhausted. Transferred data includes blocks containing recovered errors. hard err Data transfer stops when an unrecoverable error is encountered. The unrecoverable block is transferred to the initiator. The drive then creates the CHECK CONDITION status with the appropriate Sense Key.
0	0	1	1	Retries are attempted but no error correction (ECC) is applied. Recovered data (if any) are transferred with no CHECK CONDITION status at the end of the transfer. no err The transfer length is exhausted. soft err The transfer length is exhausted. Transferred data includes blocks containing recovered errors. hard err Data transfer stops when an unrecoverable error is encountered. The unrecoverable block is transferred to the initiator. The drive then creates the CHECK CONDITION status with the appropriate Sense Key.
0	1	0	0	Illegal Request-DTE must be zero when PER is zero
0	1	0	1	Illegal Request-DTE must be zero when PER is zero
0	1	1	0	Illegal Request-DTE must be zero when PER is zero
0	1	1	1	Illegal Request-DTE must be zero when PER is zero

- 1 0 0 0 The highest level error is reported at the end of transfer. Retries and error correction are attempted. Recovered and/or corrected data (if any) are transferred with CHECK CONDITION status and RECOVERED ERROR Sense Key set at the end of the transfer.
- no err** The transfer length is exhausted.
 - soft err** The transfer length is exhausted. Transferred data includes blocks containing recovered errors. The information byte in the sense data will contain the logical block address of the last recovered error.
 - hard err** Data transfer stops when an unrecoverable error is encountered. The unrecoverable block is not transferred to the initiator. The drive then creates the CHECK CONDITION status with the appropriate Sense Key.
- 1 0 0 1 The highest level error is reported at the end of transfer. Retries and error correction are attempted. Recovered and/or corrected data (if any) are transferred with CHECK CONDITION status and RECOVERED ERROR Sense Key set at the end of the transfer.
- no err** The transfer length is exhausted.
 - soft err** The transfer length is exhausted. Transferred data includes blocks containing recovered errors. The information byte in the sense data will contain the logical block address of the last recovered error.
 - hard err** Data transfer stops when an unrecoverable error is encountered. The unrecoverable block is transferred to the initiator. The drive then creates the CHECK CONDITION status with the appropriate Sense Key.
- 1 0 1 0 The highest level error is reported at the end of transfer. Retries are attempted but ECC is not applied. Recovered and/or corrected data (if any) are transferred with CHECK CONDITION status and RECOVERED ERROR Sense Key set at the end of the transfer.
- no err** The transfer length is exhausted.
 - soft err** The transfer length is exhausted. Transferred data includes blocks containing recovered errors. The information byte in the sense data will contain the logical block address of the last recovered error.
 - hard err** Data transfer stops when an unrecoverable error is encountered. The unrecoverable block is transferred to the initiator. The drive then creates the CHECK CONDITION status with the appropriate Sense Key.
- 1 0 1 0 The highest level error is reported at the end of transfer. Retries are attempted but ECC is not applied. Recovered and/or corrected data (if any) are transferred with CHECK CONDITION status and RECOVERED ERROR Sense Key set at the end of the transfer.
- no err** The transfer length is exhausted.
 - soft err** The transfer length is exhausted. Transferred data includes blocks containing recovered errors. The information byte in the sense data will contain the logical block address of the last recovered error.
 - hard err** Data transfer stops when an unrecoverable error is encountered. The unrecoverable block is transferred to the initiator. The drive then creates the CHECK CONDITION status with the appropriate Sense Key.

- 1 1 0 0 The highest level error is reported at the end of transfer. Retries and error correction are attempted. Recovered and/or corrected data (if any) are transferred with CHECK CONDITION status and RECOVERED ERROR Sense Key set at the end of the transfer.
- no err** The transfer length is exhausted.
- soft err** The transfer stops on the first soft error detected. The information in the sense data shall contain the LBA of the block in error.
- hard err** Data transfer stops on the unrecoverable error. The drive then creates the CHECK CONDITION status with the appropriate Sense Key.
- 1 1 0 1 The highest level error is reported at the end of transfer. Retries and error correction are attempted. Recovered and/or corrected data (if any) are transferred with CHECK CONDITION status and RECOVERED ERROR Sense Key set at the end of the transfer.
- no err** The transfer length is exhausted.
- soft err** The transfer stops on the first soft error detected. The information in the sense data shall contain the LBA of the block in error.
- hard err** Data transfer stops on the unrecoverable error. The unrecoverable error block is returned to the initiator. The drive then creates the CHECK CONDITION status with the appropriate Sense Key.
- 1 1 1 0 The highest level error is reported at the end of transfer. Retries are attempted but ECC is not applied. Recovered data are transferred with CHECK CONDITION status and RECOVERED ERROR Sense Key set at the end of the transfer.
- no err** The transfer length is exhausted.
- soft err** The transfer stops on the first soft error detected. The recovered error block is returned to the initiator. The information in the sense data shall contain the logical block address of the block in error.
- hard err** Data transfer stops on the unrecoverable error. The drive then creates the CHECK CONDITION status with the appropriate Sense Key.
- 1 1 1 1 The highest level error is reported at the end of transfer. Retries are attempted but ECC is not applied. Recovered and/or corrected data (if any) are transferred with CHECK CONDITION status and RECOVERED ERROR Sense Key set at the end of the transfer.
- no err** The transfer length is exhausted.
- soft err** The transfer stops on the first soft error detected. The information in the sense data shall contain the logical block address of the block in error.
- hard err** Data transfer stops on the unrecoverable error. The unrecoverable error block is returned to the initiator. The drive then creates the CHECK CONDITION status with the appropriate Sense Key.

8.8.4 Mode Page 2 (Disconnect/Reconnect Parameters)

Byte	Bit								Default
	7	6	5	4	3	2	1	0	
0	PS	RSVD=0	Page Code = 02h						82h
1	Page Length = 0Eh								0Eh
2	Read Buffer Full Ratio								00h
3	Write Buffer Empty Ratio								00h
4-5	(MSB)	Bus Inactivity Limit = 0						(LSB)	00h 00h
6-7	(MSB)	Disconnect Time Limit = 0						(LSB)	00h 00h
8-9	(MSB)	Connect Time Limit = 0						(LSB)	00h 00h
10-11	(MSB)	Maximum Burst Size						(LSB)	00h 00h
12		Fair arbitration			DIMM	RSVD	DTDC		00h
13-15	Reserved = 0								00h 00h 00h

Figure 84. Mode Page 2 (Disconnect/Reconnect Parameters)

The disconnect/reconnect page provides the initiator with the means to tune the performance of the SCSI bus.

An initiator may use the IDENTIFY message to grant the drive the general privilege of disconnecting. (Disconnect requests may still be selectively rejected by the initiator by issuing a MESSAGE REJECT).

The drive uses the disconnect/reconnect parameters to control reconnection during READ (operation code 08h and 28h) and WRITE (0Ah, 2Ah and 2E).

- **Read Buffer Full Ratio** is the numerator of a fraction whose denominator is 256. The fraction indicates how full the drive data buffer should be before attempting to reconnect to the SCSI bus. If the ratio is set to 0h, the target will calculate and use an optimal ratio based on the negotiated transfer rate.
- **Write Buffer Empty Ratio** is the numerator of a fraction whose denominator is 256. The fraction indicates how empty the drive data buffer should be before attempting to reconnect to the SCSI bus. If the ratio is set to 0h, the target will calculate and use an optimal ratio based on the negotiated transfer rate.
- **Maximum Burst Size** is the maximum amount of data that the Target transfers during a data phase before disconnecting if the Initiator has granted the disconnect privilege. This value is expressed in increments of single block size (for example, a value of 0001h means 512 bytes, 0002h means 1024 bytes when the block size is 512 bytes). Disconnections attempted by the Target are on block boundaries only. For the case when (Maximum Burst Size x Block Size) is less than the Block Length, the

Target will transfer 1 block of data before attempting to disconnect. Value of 0000h indicates there is no limit on the amount of data transferred per connection. Regardless of the value in Maximum Burst Size the Target disconnects prior to completion of the data phase if the internal data buffer segment becomes empty during a Read command or full during a Write command.

- **DIMM** (Disconnect Immediate) bit allows the Initiator to determine whether the Target is required to disconnect after the receipt of a command and prior to starting a data phase. When the DIMM is set to 1, the Target disconnects from the SCSI Bus after the receipt of a command and prior to starting a Data In or Data Out phase.

Note: Priority commands do not disconnect from the SCSI bus.

For Write (6), Write (10), Write and Verify, and Write Same commands (opcodes 0Ah, 2Ah, 2Eh, 41h), DIMM set to 0 indicates that the Target is not allowed to disconnect from the SCSI bus after receiving the command and prior to starting the Data Out phase unless the write command must be queued. The Target remains connected to the SCSI bus until the Data Out phase is started. After the Data Out phase is started, the Target may disconnect to free the SCSI bus for use by other devices.

For Read (6) and Read (10) commands, DIMM set to 0 prevents the Target from disconnecting from the SCSI Bus until it has determined that the requested data is not available in the data buffer. If the data is available, the Target will not disconnect prior to starting the data transfer unless the read command must be queued. If the data is not available, the Target disconnects until enough data has been read from the disk to satisfy the reconnection criteria as determined by the Read Buffer Full Ratio.

All other commands with DIMM set to 0 may or may not disconnect before a data phase is started.

Note: Disconnection is based on the Target's internal control algorithms, the setting of the disconnect privilege bit in the previous Identify message, and other parameters in this mode page.

- **DTDC** (Data Transfer Disconnect Control) field defines further restrictions for when a disconnect is permitted.
 - A value of 00b indicates that DTDC is not used by the Target and the disconnect is controlled by the other fields in this page.
 - A value of 01b indicates that the target shall not attempt to disconnect once the data transfer of a command has started until all data which the command is to transfer has been transferred. The connect time limit and bus inactivity limit are ignored during the data transfer.
 - The value 10b is reserved.
 - A value of 11b indicates that the target shall not attempt to disconnect once the data transfer of a command has started until the command is complete. The connect time limit and bus inactivity limit are ignored once data transfer has started.

Note: If DTDC is nonzero and the maximum burst size is nonzero, a CHECK CONDITION status will be returned. The sense key shall be set to ILLEGAL REQUEST and the additional sense code set to ILLEGAL FIELD IN PARAMETER LIST.

- **Fair arbitration** If the Fair arbitration field is set to 000b, the target shall not use arbitration fairness during normal arbitration. If this field is set to a nonzero value, the target shall use arbitration fairness during normal arbitration.

Both the Read Buffer Full Ratio and the Write Buffer Empty Ratio pertain to the current active notch. For each active notch as defined in page 0Ch there are separate Read Buffer Full Ratios and Write Buffer Empty Ratios. When the active notch is set to zero, the values are applied in mode page 0Ch across all notches.

8.8.5 Mode Page 3 (Format Device Parameters)

Byte	Bit							
	7	6	5	4	3	2	1	0
0	PS = 0	RSVD= 0	Page Code = 03h					
1	Page Length = 16h							
2	(MSB) Tracks per Zone (LSB)							
3								
4	(MSB) Alternate Sectors per Zone = 0 (LSB)							
5								
6	(MSB) Alternate Tracks per Zone = 0 (LSB)							
7								
8	(MSB) Alternate Tracks per Logical Unit = 0 (LSB)							
9								
10	(MSB) Sectors Per Track (LSB)							
11								
12	(MSB) Data Bytes per Physical Sector (LSB)							
13								
14	(MSB) Interleave = 1 (LSB)							
15								
16	(MSB) Track Skew Factor (LSB)							
17								
18	(MSB) Cylinder Skew Factor (LSB)							
19								
20	SSEC	HSEC	RMB	SURF	RESERVED			
21-23	RESERVED							

Figure 85. Mode Page 3 (Format Device Parameters)

The format device page contains parameters which specify the medium format. This page contains no changeable parameters.

Tracks per Zone specifies the number of tracks within the zone. This field is a function of the active notch.

A value of 0 in the following parameters indicates that they are Target specific.

- Alternate Sectors per Zone
- Alternate Tracks per Zone
- Alternate Tracks per Logical Unit

Sectors per Track specifies the number of physical sectors within each track. This field is a function of the active notch.

Data Bytes per Physical Sector specifies the number of user data bytes per physical sector. The value depends upon the current formatted Block Length.

Track Skew Factor indicates the number of physical sectors between the last block of one track and the first block on the next sequential track of the same cylinder. This field is a function of the active notch.

Cylinder Skew Factor indicates the number of physical sectors between the last block of one cylinder and the first block on the next sequential cylinder. This field is a function of the active notch.

SSEC = Zero indicates that the drive does not support soft sector formatting.

HSEC = One indicates that the drive supports hard sector formatting.

RMB = Zero indicates that the media does not support removable. Fixed Disk.

SURF = Zero indicates that progressive addresses are assigned to all logical blocks in a cylinder prior to allocating addresses within the next cylinder.

8.8.6 Mode Page 4 (Rigid Disk Drive Geometry Parameters)

Byte	Bit							
	7	6	5	4	3	2	1	0
0	RSVD= 0		Page Code = 04h					
1	Page Length = 16h							
2-4	(MSB) Number of Cylinders							(LSB)
5	Number of heads							
6-8	(MSB) Starting Cylinder - Write Precompensation = 0							(LSB)
9-11	(MSB) Starting Cylinder - Reduced Write Current = 0							(LSB)
12-13	(MSB) Drive Step Rate (Not used)							(LSB)
14-16	(MSB) Landing Zone Cylinder (Not used)							(LSB)
17	RESERVED					RPL = 0		
18	Rotational Offset = 00 (Not used)							
19	RESERVED							
20-21	(MSB) Medium Rotation Rate in RPM							(LSB)
22-23	RESERVED							

Figure 86. Mode Page 4 (Rigid Disk Drive Geometry Parameters)

The rigid disk drive geometric page specifies various parameters for the drive.

RPL Zero. Indicates that the drive does not support spindle synchronization.

8.8.7 Mode Page 7 (Verify Error Recovery Parameters)

Byte	Bit								Default	
	7	6	5	4	3	2	1	0		
0	PS	RSVD=0	Page Code = 07h							87h
1	Page Length = 0Ah								0Ah	
2	Reserved = 0			EER=0	PER	DTE=0	DCR		00h	
3	Verify Retry Count								01h	
4	Correction Span = 00h								00h	
5	Reserved = 0								00h	
6	Reserved = 0								00h	
7	Reserved = 0								00h	
8	Reserved = 0								00h	
9	Reserved = 0								00h	
10	(MSB)	Verify Recovery Time Limit (Not Used)						(LSB)	00h	
11									00h	

Figure 87. Mode Page 7 (Verify Error Recovery Parameters)

The Verify recovery parameters are used by the Target when recovering from and reporting errors associated with the verification of the initiator's Data for the following commands:

- Verify
- Write and Verify - the verify portion of the command only.

Since bytes 4-11 are not changeable, the Mode Select Commands accepts only the values indicated for bytes 4 - 11.

- **EER.** This bit is 0 since the Target does not support early recovery.
- **PER.** See below for description of bit values.
- **DTE.** This bit is 0 since the Target always continues on recovered verify operation errors.
- **DCR.** See below for description of bit values.

PER, DTE, and DCR bit settings in page 7 override those of page 1 during Verify and the Verify portion of Write and Verify. There are only four valid conditions for the PER, DTE, and DCR bits. All other combinations return Check Condition Status.

PER	DTE	DCR	DESCRIPTION
0	0	0	Soft errors are not reported. ECC is applied to recover the data.
1	0	0	Soft errors are reported. ECC is applied to recover the data.
0	0	1	Soft errors are not reported. ECC is not used to recover the data.
1	0	1	Soft errors are reported. ECC is not used to recover the data.

- **Verify Retry Count** sets a limit on the amount of verify recovery procedure (VRP) passes the Target attempts when recovering verify errors. The Verify Retry Count of one causes the Target to attempt up to one VRP pass per command when a medium error occurs during a verify operation. Only values of 0h and 01h are valid. The value of 0h disables all recovery.
- **Verify Correction Span** field specifies the size in bits of the largest data error burst for which data error correction may be attempted. The field may be set to any value but the drive will not use off-line correction during verify operations.

8.8.8 Mode Page 8 (Caching Parameters)

Byte	Bit								Default	
	7	6	5	4	3	2	1	0		
0	PS	RSVD=0	Page Code = 08h							88h
1	Page Length = 12h								12h	
2	IC	ABPF	CAP	DISC	SIZE	WCE	MF	RCD	04h	
3	Demand Read Retention Priority				Write Retention Priority				00h	
4-5	Disable Pre-fetch Transfer Length								FFh FFh	
6-7	Minimum Pre-fetch								00h 00h	
8-9	Maximum Pre-fetch								FFh FFh	
10-11	Maximum Pre-fetch Ceiling								00h	
12	FSW	LBCSS	DRA	Reserved = 0						00h
13	Number of Cache Segments								0Eh	
14-15	(MSB)	Cache Segment Size						(LSB)	00h 00h	
16	Reserved = 0								00h	
17 18,19	(MSB)	Non Cache Segment Size						(LSB)	000000h	

Figure 88. Page 8 (Caching Parameters)

The caching parameters page defines parameters that affect the use of the cache.

- **IC** (Initiator Control) is internally ignored by the Target. The Target will always use the Number of Cache Segments or Cache Segment Size fields.
- **ABPF** (Abort Pre-Fetch) is not supported. The Target aborts the pre-fetch based on the internal algorithm.
- **CAP** (Caching Analysis Permitted) is not supported and is internally ignored by the Target.
- **DISC** (Discontinuity) is not supported and is internally ignored by the Target.
- **SIZE** (Size Enable) bit when set to one indicates that the Cache Segment Size is to be used to control caching segmentation. When SIZE is set to zero, the initiator requests that the Number of Cache Segments is to be used to control caching segmentation.
- **WCE** (Write Cache Enable) bit when set at zero indicates that the drive must issue Good Status for Write(6) or Write extend(10) command only after successfully writing the data to the media. When

the WCE bit is set to one, the drive may issue Good Status for a Write(6) or Write extend(10) command after successfully receiving the data but before writing it to the media. When WCE = 1, the drive operates as if AWRE = 1.

Note: When WCE = 1, a Synchronize Cache command must be done to assume data is written to the media before powering down the Target.

- **MF** (Multiplication Factor) determines how the Maximum Pre-fetch field is interpreted. When this bit is set, the data to pre-fetch is given by the command length multiplied by the value in the Maximum Pre- fetch field. When this bit is reset the value in the Maximum pre-fetch field is used as the absolute length to pre-fetch.
- **RCD** (Read Cache Disable) bit set at zero indicates that the drive may return some or all of the data requested by a Read (6) or Read (10) command by accessing the data buffer, not the media. An RCD bit set at one indicates that the Target does not return any of the data requested by a Read (6) or Read (10) command by accessing the data buffer. All of the data requested is read from the media instead.
- **Demand Read Retention Priority** sets the Retention Priority of data requested on a Read Command. It may be set to 0h, 1h, or Fh as defined below.

Value 0h : Do not distinguish between Requested Data and Other Data.

Value 1h : Replace Requested Data before Other Data.

Value Fh : Replace Other Data before Requested Data.

The Value is the Demand Read Retention Priority or Write Retention Priority. Requested Data are the blocks specified in the Read or Write Command. Other Data are data in the cache from any other operation such as Pre-fetch or Read-Ahead.

If the Read Retention Priority is not set to Fh or if the DPO bit on the Read command is one, the Requested data is overwritten by Read-Ahead data.

If the DPO bit is 0 and the Read Retention Priority is set to Fh, the Requested Data is not overwritten with Read-Ahead Data. If the requested transfer is larger than the segment, the Requested Data is overwritten with more Requested Data and there is no Read-Ahead.

- **Write Retention Priority** sets the Retention Priority of data provided on a Write Command. It may be set to 0h, 1h, or Fh. See definition of Demand Read Retention Priority above for more details.
- **Disable Pre-fetch Transfer Length** specifies a number of LBA's which if exceeded by a read command length will cause the drive not to perform read ahead buffering after the command has completed. A value of zero specifies read ahead is disabled.
- **Minimum Pre-fetch** specifies the minimum number of LBA's that the drive should read ahead after each read command. A value of zero indicates that read ahead should be terminated immediately after a new command arrives, except when the new command is on the current head and track.
- **Maximum Pre-fetch** specifies the maximum number of LBA's to read ahead after a read command. This field can either be used as an absolute value, if the MF bit is set at zero, or it will be multiplied by the read command length to give the actual length to read ahead.
- **Maximum Pre-fetch ceiling** specifies the maximum number of blocks the drive should attempt to read ahead. It is particularly relevant when the MF bit is set.
- **FSW** (Force Sequential Write) is not supported and internally ignored by the Target.
- **LBCSS** (Logical Block Cache Segment Size) bit when set to one indicates that the Cache Segment Size field units shall be interpreted as logical blocks. When it is set to zero, the Cache Segment Size field units shall be interpreted as bytes.
- **DRA** (Disable Read Ahead) bit when set to one requests that the target not read into the buffer any logical block beyond the addressed logical block(s). When it is set at zero, the target may continue to read logical blocks into the buffer beyond the addressed logical block(s).

- **Number of Cache Segments** field is used to select the number of data buffer cache segments. This parameter is valid only when the SIZE bit is set at zero. It is ignored when SIZE is set at one.

The target supports the following Cache Segment configuration:

Number of Segments	Segment Size
7	512K
14	256K
28	128K

- **Cache Segment Size** field indicates the requested segment size in Bytes or Blocks, depending upon the value of the LBCSS bit. The Cache Segment Size field is valid only when the SIZE bit is one. It is ignored when SIZE is set at zero. The drive considers this a minimum size. It will be rounded to a value of 7, 14 or 28 segments.
- **Non Cache Segment Size** fields are internally ignored by the Target.

8.8.9 Mode Page A (Control Mode Page Parameters)

Byte	Bit								Default
	7	6	5	4	3	2	1	0	
0	PS	RSVD=0	Page Code = 0Ah						8Ah
1	Page Length = 0Ah								0Ah
2	Reserved = 0							RLEC=0	00h
3	Queue Algorithm Modifier				Reserved = 0		QErr	DQue	00h
4	EECA=0	Reserved = 0				RAENP = 0	UAAENP = 0	EAENP = 0	00h
5	Reserved = 0								00h
6-7	(MSB)	Ready AEN Holdoff Period						(LSB)	00h
8-9	(MSB)	Busy Timeout Period						(LSB)	00h
10-11	(MSB)	Extended Self-test Routine Completion Time						(LSB)	---

Figure 89. Page A (Control Mode Page Parameters)

Following are parameter options for Page 0A of MODE SELECT.

- Queue algorithm modifier** specifies restrictions on the algorithm used for reordering commands that are tagged with the SIMPLE QUEUE TAG message.
 - 0h : Restricted reordering. The target shall reorder the actual execution sequence of the queued commands from each initiator such that data integrity is maintained for that initiator.
 - 1h : Unrestricted reordering allowed. The target may reorder the actual execution sequence of the queued commands in any manner it selects. Any data integrity exposures related to command sequence order are explicitly handled by the initiator through the selection of appropriate commands and queue tag messages.
 - 2h-7h : RESERVED.
 - 8 : Command reordering is disabled
 - 9-Fh : RESERVED
- QErr (Queue Error Management)** bit of zero specifies that the Target suspends execution of queued and active commands from any Initiator which receives a Check Condition Status until pending sense data is cleared. Those commands still queued after the Target has returned Check Condition Status, continue execution in a normal manner when the pending status is cleared. A QErr bit of one specifies that all active commands and all queued commands from all initiators are aborted when the Target returns the Check Condition Status. A unit attention condition will be generated for each initiator which had commands in the queue except for the initiator that received the Check Condition Status. The sense key will be set to Unit Attention and the additional sense code will be set to COMMANDS CLEARED BY ANOTHER INITIATOR.

- **DQue** (Disable Queuing) bit set at zero specifies that tagged queuing shall be enabled if the target supports tagged queuing. A DQue bit set at one specifies that tagged queuing shall be disabled. Any queue commands for that I_T_L nexus shall be aborted. Any subsequent queue tag message received shall be rejected with a MESSAGE REJECT message and I/O process shall be executed as an untagged command.
- **Ready AEN Holdoff Period** is ignored internally by the Target.
- **Busy Timeout Period** is ignored internally by the Target.
- **Extended Self-test Routine Completion Time** is an advisory parameter that an initiator may use to determine the time in seconds that the target requires to complete self-test routine when the target is not interrupted by an initiator and no errors occur during execution of the self-test routine.

8.8.10 Mode Page 0C (Notch Parameters)

Byte	Bit							
	7	6	5	4	3	2	1	0
0	PS = 0	RSVD= 0	Page Code = 0Ch					
1	Page Length = 16h							
2	ND = 1	LPN = 0	RSVD = 0					
3	Reserved = 0							
4	(MSB) Maximum Number of Notches = 0Bh (LSB)							
5								
6	(MSB) Active Notch (LSB)							
7								
8 11	(MSB) Starting Boundary (LSB)							
12 15	(MSB) Ending Boundary (LSB)							
16 23	(MSB) Pages Notched = 000000000000100Ch (LSB)							

Figure 90. Page 0C (Notch Parameters)

The notch page contains parameters for direct-access devices which implement a variable number of blocks per cylinder. Each section of the logical unit with a different number of blocks per cylinder is referred as a notch. The only field that is changeable is the **Active Notch** field.

ND = ONE meaning that this device is a notched drive.

LPN = ZERO meaning that the notches are based upon physical parameters of the drive (cylinder #), not logical parameters.

Maximum Number of Notches is the number of notches the drive can support.

Active Notch indicates to which notch subsequent Mode Select/Sense command parameters pertain. A value of 0 is used for parameter values which apply to all notches. Values from 1 to the maximum value depending on the model specify the notch number, where notch 1 is the outermost notch. Following mode parameters are based on the current active notch:

- Mode Page 2
 - Read Buffer Full Ratio
 - Write Buffer Empty Ratio

- Mode Page 3
 - Alternate Sector per Zone
 - Alternate Track per Zone
 - Alternate Track per Logical Unit
 - Sector per Track
 - Track Skew Factor
 - Cylinder Skew Factor

Starting Boundary contains the first physical location of the active notch. The first three bytes are the cylinder number and the last byte is the head. The value sent in this field is ignored.

Ending Boundary contains the last physical location of the active notch. The first three bytes are the cylinder number and the last byte is the head. The value sent in this field is ignored.

Pages Notched is a bit map of the mode page codes that indicates which pages contain parameters that may be different for different notches. The most significant bit of this field corresponds to page code 3Fh and the least significant bit corresponds to page code 00h. If a bit is one, then the corresponding mode page contains parameters that may be different for different notches. If a bit is zero, then the corresponding mode page contains parameters that are constant for all notches.

8.8.11 Mode Page 19 (Port Control)

Byte	Bit								Default	
	7	6	5	4	3	2	1	0		
0	PS	RSVD	Page Code = 019h							99h
1	Page Length = 06h								06h	
2	Reserved = 0								00h	
3	Reserved = 0				Protocol identifier = 1				01h	
4 5	(MSB) Synchronous transfer timeout (LSB)								00h 00h	
6	Reserved = 0								00h	
7	Reserved = 0								00h	

Figure 91. Page 19 (Port Control)

- **Protocol identifier** field has a value of 1h to indicate SPI SCSI devices.
- **Synchronous transfer timeout** field must be 0000h.

8.8.12 Mode Page 1A (Power Control)

Byte	Bit							
	7	6	5	4	3	2	1	0
0	RSVD = 0	RSVD = 0	Page Code = 1Ah					
1	Page Length = 0Ah							
2	Reserved = 00h							
3	Reserved = 0						Idle	Standby
4 7	(MSB) Idle Condition Timer = 0						(LSB)	
8 11	(MSB) Standby Condition Timer						(LSB)	

Figure 92. Page 1A (Power Control)

- The value for the **Idle Condition Timer** and the corresponding **Idle** control bit is accepted. Despite this, the drive does not alter the internal power saving algorithms based upon this value.
- **Standby** bit of one indicates that the target shall use the **Standby Condition Timer** to determine the length of inactivity time to wait before entering the Standby condition. A standby bit of zero indicates that the target shall not enter the Standby condition.
- **Standby Condition Timer** field indicates the inactivity time in 100 millisecond increments that the target shall wait before entering the Standby condition. The minimum allowable inactivity time is 60 minutes. Any value less than this is accepted, but will automatically default to 60 minutes.

8.8.13 Mode Page 1C (Informational Exceptions Control)

Byte	BIT								Default							
	7	6	5	4	3	2	1	0								
0	PS	RSVD=0	Page Code = 1Ch							9Ch						
1	Page Length = 0Ah								0Ah							
2	PERF	RSVD	EBF	EWASC	DEXCPT	TEST	RSVD	LOGERR	00h							
3	Reserved = 0				Method of Reporting				00h							
4	Interval Timer								00h							
5									(MSB)							00h
6																00h
7															(LSB)	00h
8	Report Count								00h							
9									(MSB)							00h
10																00h
11															(LSB)	00h

Figure 93. Page 1C (Informational Exceptions Control)

- **LOGERR** (Log Errors) is not used and ignored internally by the Target.
- **EWASC** (Enable Warning ASC) bit of zero indicates that Temperature Warning will not be reported. An EWASC bit of one allows Temperature Warning to be reported when DEXCPT bit is set to zero. If the temperature reading inside of DE exceeds the threshold (default or set by Mode Select Page 0), Recovered Error (Sense Key 01h, ASC 0Bh, ASCQ 01h) will be reported.
DEXCPT bit of zero indicates that informational exception operations shall be enabled. The reporting of informational exception conditions when the DEXCPT bit is set to zero is determined from the method of reporting informational exceptions field.
Note: Disable exception control (DEXCPT) bit of zero indicates the failure prediction threshold exceeded reporting shall be enabled. The method for reporting the failure prediction threshold exceeded when the DEXCPT bit is set to zero is determined from the method of reporting informational exceptions field. A DEXCPT bit of one indicates the target shall disable reporting of the failure prediction threshold exceeded. The method of reporting informational exceptions field is ignored when DEXCPT is set to one and EWASC is set to zero.
- **DEXCPT** (Disable Exception Control) bit of zero indicates information exception operations are enabled. The reporting of information exception conditions when the DEXCPT bit is set to zero is determined from the Method of Reporting field. A DEXCPT bit of one indicates the Target disabled all information exception operations.
- **TEST** bit of one instructs the drive to generate false drive notifications at the next interval time, (as determined by the INTERVAL TIMER field), if the DEXCPT is zero. The Method of Reporting and Report Count would apply. The false drive failure is reported as sense qualifier 5DFFh. The TEST bit of zero instructs the drive to stop generating any false drive notifications.

- **EBF** (Enable Background Function) bit of one indicates that the target enables background functions. An EBF bit of zero indicates that the target disables the functions.
- **PERF** (Performance) bit is not used and ignored internally by the Target.
- **Method of Reporting** Informational Exceptions indicates the methods used by the Target to report informational exception conditions.

Code	Description
0h	No reporting of informational exception condition: This method instructs the target to not report informational exception condition.
1h	Asynchronous event reporting: Not supported.
2h	Generate unit attention: This method instructs the target to report informational exception conditions by returning a CHECK CONDITION status on any command. The sense key is set to UNIT ATTENTION and the additional sense code indicates the cause of the informational exception condition. The command that has the CHECK CONDITION is not executed before the informational exception condition is reported.
3h	Conditionally generate recovered error: This method instructs the target to report informational exception conditions, dependent on the value of the PER bit of the error recovery parameters mode page, by returning a CHECK CONDITION status on any command. The sense key is set to RECOVERED ERROR and the additional sense code indicates the cause of the informational exception condition. The command that has the CHECK CONDITION completes without error before any informational exception condition is reported.
4h	Unconditionally generate recovered error: This method instructs the target to report informational exception conditions, regardless of the value of the PER bit of the error recovery parameters mode page, by returning a CHECK CONDITION status on any command. The sense key is set to RECOVERED ERROR and the additional sense code indicates the cause of the informational exception condition. The command that has the CHECK CONDITION completes without error before any informational exception condition is reported.
5h	Generate no sense: This method instructs the target to report informational exception conditions by returning a CHECK CONDITION status on any command. The sense key is set to NO SENSE and the additional sense code indicates the cause of the informational exception condition. The command that has the CHECK CONDITION completes without error before any informational exception condition is reported.
6h	Only report informational exception condition on request: This method instructs the target to preserve the informational exception(s) information. To find out about informational exception conditions the Application Client polls the target by issuing an unsolicited REQUEST SENSE command. The sense key is set to NO SENSE and the additional sense code indicates the cause of the informational exception condition.
7h-Fh	Reserved.

- **Interval Timer** field indicates the period in 100 millisecond increments for reporting that an informational exception condition has occurred. The target shall not report informational exception conditions more frequently than the time specified by the Interval Timer field and as soon as possible after the time interval has elapsed. After the informational exception condition has been reported the interval timer is restarted. A value of zero in the Interval Timer field indicated that the target only reports the informational exception condition one time.
- **Report Count** field indicates the number of times the target reports an informational exception condition. The Report Count of ZERO indicates no limits on the number of times the target reports an informational exception condition.

8.9 MODE SENSE (5A)

Byte	Bit							
	7	6	5	4	3	2	1	0
0	Command Code = 5Ah							
1	Reserved = 0		RSVD	DBD	Reserved = 0			
2	PCF		Page Code					
3	Reserved = 0							
4	Reserved = 0							
5	Reserved = 0							
6	Reserved = 0							
7-8	(MSB)	Allocation Length						(LSB)
9	VU = 0		Reserved = 0			FLAG	LINK	

Figure 94. MODE SENSE (5A)

The MODE SENSE (5A) command provides a means for the drive to report various device parameters to the initiator. See the MODE SENSE (1A) command for a description of the fields in this command.

8.10 MODE SELECT (15)

Byte	Bit							
	7	6	5	4	3	2	1	0
0	Command Code = 15h							
1	Reserved = 0		PF=1	Reserved = 0			SP	
2 3	Reserved = 0							
4	Parameter List Length							
9	VU = 0		Reserved = 0			FLAG	LINK	

Figure 95. MODE SELECT (15)

The MODE SELECT (15) command provides a means for the initiator to specify LUN or device parameters to the Target. It also allows an Initiator to specify options the Target uses in error recovery and Caching.

There is a single set of Mode Page parameters shared by all initiators.

PF A PF (Page Format) bit value of one indicates that the data sent by the Initiator after the Mode Select Header and the Block Descriptor, if any, complies to the Page Format. The Target ignores this field since it only accepts mode parameters in the Page Format.

SP Pages. This indicates

- 0 The drive shall not save the pages sent during the Data Out phase but will use them for all following commands until the power is removed, a reset is received, or a new mode select command is received.
- 1 The drive will save the data in the reserved area of the disk. It will be used for all the following commands until another mode select command is issued. This information is maintained over a power cycle or reset of the drive.

Parameter List Length

This specifies the number of bytes to be sent from the initiator. A parameter list length of zero suppresses data transfer and is not considered as an error.

The MODE SELECT parameter list contains a four-byte header, followed by zero or one block descriptor followed by zero or more pages. The pages which are valid with this command are defined in the addendum under the heading **Mode Select Data** as they vary with the drive model.

Application Note

The initiator should issue a MODE SENSE command requesting all Changeable values (see PCF field in byte two of the CDB in **MODE SENSE (1A)** on page 92) prior to issuing a MODE SELECT command. This is necessary to find out which pages are implemented by the drive and the length of those pages. In the Pages of the MODE SENSE command the drive will return the number of bytes supported for each Page. The Page Length set by the initiator in the MODE SELECT command must be same value

as returned by the drive in MODE SENSE Page Length. If not, the drive will return CHECK CONDITION status with sense key of ILLEGAL REQUEST.

Note: If an initiator sends a MODE SELECT command that changes any parameters that apply to other initiators, the drive shall generate an unit attention condition for all initiators except for the one that issued the MODE SELECT command. The drive shall set the additional sense code to PARAMETERS CHANGED (2Ah).

8.11 MODE SELECT (55)

Byte	Bit							
	7	6	5	4	3	2	1	0
0	Command Code = 55h							
1	Reserved = 0		PF=1	Reserved = 0			SP	
2 3 4 5 6	Reserved = 0							
7 8	(MSB) Parameter List Length							(LSB)
9	VU = 0		Reserved = 0			FLAG	LINK	

Figure 96. MODE SELECT (55)

The MODE SELECT (55) command provides a means for the initiator to specify LUN or device parameters to the Target. See the MODE SELECT (15) command for a description of the fields in this command.

8.12 PERSISTENT RESERVE IN (5E)

Byte	Bit							
	7	6	5	4	3	2	1	0
0	Command Code = 5Eh							
1	Reserved = 0			Service Action				
2	Reserved = 0							
3								
4								
5								
6								
7	(MSB) Allocation Length							(LSB)
8								
9	VU = 0		Reserved = 0			FLAG	LINK	

Figure 97. Persistent Reserve In (5E)

When a drive receives a PERSISTENT RESERVATION IN command and RESERVE(6) or RESERVE(10) logical unit is active, the command is rejected with a RESERVATION CONFLICT status.

PERSISTENT RESERVATION IN command does not conflict with a reservation established by the PERSISTENT RESERVATION OUT command.

8.12.1 Service Action

Ultrastar 36LZX implements following service action codes. If a reserved service action code is specified, the drive returns a CHECK CONDITION status. The sense key is set to ILLEGAL REQUEST and the additional sense data is set to INVALID FIELD IN CDB.

Code	Name	Descriptions
00h	Read Keys	Reads all registered Reservation Keys
01h	Read Reservations	Reads all current persistent reservations
02h-1Fh	Reserved	Reserved

Figure 51. PERSISTENT RESERVE IN Service Action Codes

8.12.2 Parameter data for Read Keys

Byte	Bit							
	7	6	5	4	3	2	1	0
0 3	(MSB) Generation (LSB)							
4 7	(MSB) Additional length (n-7) (LSB)							
8 15	(MSB) First reservation key (LSB)							
	:							
n-7 n	(MSB) Last reservation key (LSB)							

Figure 98. PERSISTENT RESERVE IN parameter data for Read Keys

Generation is a counter which increments when PERSISTENT RESERVATION OUT command with “Register” or “Preempt and Clear” completes successfully. Generation is set to 0 as part of the power on reset process and hard reset process.

8.12.3 Parameter data for Read Reservations

Byte	Bit							
	7	6	5	4	3	2	1	0
0 3	(MSB) Generation (LSB)							
4 7	(MSB) Additional length (n-7) (LSB)							
8 n	(MSB) Reservation descriptors (LSB)							

Figure 99. PERSISTENT RESERVE IN parameter data for Read Reservations

Byte	Bit							
	7	6	5	4	3	2	1	0
0 7	(MSB) Reservation key (LSB)							
8 11	(MSB) Scope-specific address (LSB)							
12	Reserved							
13	Scope				Type			
14 15	(MSB) Extent length (LSB)							

Figure 100. PERSISTENT RESERVE IN Read Reservation Descriptor

Scope-specific address is filled with 0.

Scope and **Type** are described in PERSISTENT RESERVATION OUT command section.

Extent length is filled with 0.

8.13 PERSISTENT RESERVE OUT (5F)

Byte	Bit							
	7	6	5	4	3	2	1	0
0	Command Code = 5Fh							
1	Reserved = 0			Service Action				
2	Scope				Type			
3	Reserved = 0							
4								
5								
6								
7	(MSB) Parameter List Length = 18h							(LSB)
8								
9	VU = 0	Reserved = 0			FLAG	LINK		

Figure 101. Persistent Reserve Out (5F)

When a drive receives a PERSISTENT RESERVATION OUT command and RESERVE(6) or RESERVE(10) logical unit is active, the command is rejected with a RESERVATION CONFLICT status.

Parameter List Length must be 18h. If not, the drive returns CHECK CONDITION status. And the sense key is set to ILLEGAL REQUEST and the additional sense data is set to PARAMETER LIST LENGTH ERROR

8.13.1 Service Action

Ultrastar 36LZX implements service action codes as follows. If a code which is not supported or a reserved code is specified, the drive returns a CHECK CONDITION status. The sense key is set to ILLEGAL REQUEST and the additional sense data is set to INVALID FIELD IN CDB. In case of PERSISTENT RESERVATION OUT command executing a Register service action, this field is ignored.

Code	Name	Description	Support
00h	Register	Register a reservation key with the device server	Yes
01h	Reserve	Create a persistent reservation using a reservation key	Yes
02h	Release	Release a persistent reservation	Yes
03h	Clear	Clear all reservation keys and all persistent reservations	No
04h	Preempt	Preempt persistent reservations from another initiator	No
05h	Preempt and Clear	Preempt persistent reservations from another initiator and clear the task set for the preempted initiator	Yes
06h - 1Fh	Reserved	Reserved	---

Figure 102. Persistent Reservation Service Action Code

Register This service action may conflict with a successfully established persistent reservation.

If the key specified in the Reservation Key field is not registered yet, a key specified in the Service Action Reservation Key is registered as new key. If the key is already registered but the initiator which registered the key is different from the initiator requesting the command, the drive returns RESERVATION CONFLICT status. If the key is already registered and the key is for the initiator requesting the command, the key is replaced with new key specified in the Service Action Reservation Key field.

Ultrastar 36LZX holds up to 4 keys at the same time. When 4 keys are already registered, PERSISTENT RESERVATION OUT command with Register service action which does not replace an existing key is rejected with RESERVATION CONFLICT status.

When PERSISTENT RESERVATION OUT command with Register service action completes successfully, the Generation counter is incremented.

When keys are registered, the drive returns RESERVATION CONFLICT status against the RESERVE command and the RELEASE command.

Reserve This service action does not conflict with a successfully established persistent reservation.

If the initiator has not previously performed a Register service action, the command with this service action is rejected with RESERVATION CONFLICT status.

If the key specified in the Reservation key field is already registered but the initiator which registered the key is different from the initiator requesting the command, the target returns RESERVATION CONFLICT status.

If persistent reservation that is being attempted conflicts with persistent reservation that is held, the target returns a RESERVATION CONFLICT status.

The established persistent reservation applies to all commands received after the successful completion of the command.

Release This service action may conflict with a successfully established persistent reservation.

If the initiator requesting the command has not previously performed a Register service action, the command is rejected with a status of RESERVATION CONFLICT status.

If the key specified in the Reservation key field is already registered but the initiator which registered the key is different from the initiator requesting the command, the drive returns a RESERVATION CONFLICT status.

The drive returns GOOD status when a key specified in Reservation key field is not found.

When the key is found but the scope is different from the registered scope or the type is different from the registered type, the command is rejected with CHECK CONDITION status. The sense key is set to ILLEGAL REQUEST and the additional sense data is set to INVALID RELEASE OF ACTIVE PERSISTENT RESERVATION.

Preempt and Clear This service action does not conflict with a successfully established persistent reservation.

If the initiator requesting the command has not previously performed a Register service action, the command is rejected with a status of RESERVATION CONFLICT.

If the key specified in the Reservation key field is already registered but the initiator which registered the key is different from the initiator requesting the command, the drive returns a RESERVATION CONFLICT status.

Even if the key specified in the Service Action Reservation key field is not registered, the drive makes new persistent reservation without preempting if it does not conflict with an existing persistent reservation.

When the key is registered but reservation for the key is nothing yet and the new persistent reservation does not conflict with an existing persistent reservation, the drive makes new persistent reservation and clears the key and all commands from the initiator which was registered the key.

When the key specified in the Service Action Reservation Key is cleared even if a reservation for the key is nothing yet, the drive makes UNIT ATTENTION condition for the initiator which was registered the key. The sense key is set to UNIT ATTENTION and the additional sense data is set to RESERVATION PREEMPTED.

When PERSISTENT RESERVATION OUT command with this service action completes successfully, the Generation counter is incremented.

The target does not clear any ACA condition associated with the initiator being preempted because of the restriction of implementation for ACA handling. When any ACA condition is generated for an initiator and any command from another initiator is requested, the drive enqueues the command but does not reconnect for the command until the ACA condition is cleared by the initiator associating the ACA condition.

8.13.2 Scope

Ultrastar 36LZX implements scope codes as follows. If a code which is not supported or a reserved code is specified, the drive returns a CHECK CONDITION status. The sense key is set to ILLEGAL REQUEST and the additional sense data is set to INVALID FIELD IN CDB. In case of PERSISTENT RESERVATION OUT command executing a Register service action, this field is ignored.

Code	Name	Description	Support
0h	LU	Persistent reservation applies to the full logical unit	Yes
1h	Extent	Persistent reservation applies to the specific extent	No
2h	Element	Persistent reservation applies to the specific element	No
3h - Fh	Reserved	Reserved	---

Figure 103. Persistent Reservation Scope Code

8.13.3 Type

Ultrastar 36LZX implements type codes as follows. If a code which is not supported or a reserved code is specified, the target returns a CHECK CONDITION status. The sense key is set to ILLEGAL REQUEST and the additional sense data is set to INVALID FIELD IN CDB. In case of PERSISTENT RESERVATION OUT command executing a Register service action, this field is ignored.

Code	Name	Support	RD	WR	NWR	Add Rsv
0h	Read Shared	No	---	---	---	---
1h	Write Exclusive	Yes	SH	EX	PH	A1
2h	Read Exclusive	No	---	---	---	---
3h	Exclusive Access	Yes	EX	EX	PH	A1
4h	Shared Access	No	---	---	---	---
5h	Write Exclusive Registrants Only	Yes	SH	EO	PH	A2
6h	Exclusive Access Registrants Only	Yes	EO	EO	PH	A2
7h - Fh	Reserved	---	---	---	---	---

Figure 104. Persistent Reservation Type Code

RD READ command and READ EXTENDED command

- WR** WRITE command and WRITE EXTENDED command
- NWR** Commands except following,
- READ command and READ EXTENDED command
 - WRITE command and WRITE EXTENDED command
 - RESERVE and RELEASE command
- If any key is registered, the target returns a RESERVATION CONFLICT status.
- PERSISTENT RESERVE IN command and PERSISTENT RESERVE OUT command
- SH** SHared: The target executes the command from all initiators.
- EX** EXclusive: The target executes the command from initiator which holds the the persistent reservation and rejects the command from the other initiators with RESERVATION CONFLICT status.
- PH** ProHibited: The target rejects the command from all initiators.
- EO** Exclusive registrant Only: The target executes the command from initiator which has registered a key and rejects the command from the other initiators with RESERVATION CONFLICT status.
- A1** The target rejects new PERSISTENT RESERVATION on any types and returns RESERVATION CONFLICT status
- A2** The target accepts new PERSISTENT RESERVATION with Write Exclusive Registrants Only type and Exclusive Access Registrants Only type. The target rejects new PERSISTENT RESERVATION with Write Exclusive type and Exclusive Access type and returns RESERVATION CONFLICT status

New Type \ Existing Type	1	3	5	6
Write Exclusive (1)	Yes	Yes	Yes	Yes
Exclusive Access (3)	Yes	Yes	Yes	Yes
Write Exclusive Registrants Only (5)	Yes	Yes	No	No
Exclusive Access Registrants Only (6)	Yes	Yes	No	No

Figure 105. Conflict between new and existing PERSISTENT RESERVATION

8.13.4 Parameter list

Byte	Bit							
	7	6	5	4	3	2	1	0
0 7	(MSB) Reservation Key (LSB)							
8 15	(MSB) Service Action Reservation Key (LSB)							
16 19	(MSB) Scope-specific address (LSB)							
20	Reserved						APTPL	
21	Reserved							
22 23	(MSB) Extent length (LSB)							

Figure 106. PERSISTENT RESERVATION OUT parameter list

8.13.5 Summary

Service Action	Parameters						Gener- ation counter
	Scope Type	Rsv Key	SvcAct RsvKey	S-spec addr	Extent length	APTPL	
(0) Register	ignore	verify	save	ignore	ignore	apply	+ 1
(1) Reserve	apply	verify	ignore	ignore	ignore	ignore	---
(2) Release	apply	verify	ignore	ignore	ignore	ignore	---
(5) Preempt and Clear	apply	verify	save	ignore	ignore	ignore	+ 1

Figure 107. Service Action and parameters and generation counter

8.13.5.1 Scope, Type

The Scope and the Type are applied in the process for the Reserve, Release, and Preempted and Clear service action but they are ignored in the process for the Register service action because they are not used.

8.13.5.2 Reservation Key

The Reservation Key is verified in each service action process. If the initiator which registered a key is different from the initiator requesting PERSISTENT RESERVATION OUT command, the drive returns a RESERVATION CONFLICT status.

8.13.5.3 Service Action Reservation Key

On Register service action, the drive saves the key specified in the Service Action Reservation Key field as a key of initiator requesting PERSISTENT RESERVATION OUT command.

On Preempt and Clear service action, the reservation which has a key specified in the Service Action Reservation Key field is preempted.

On other service actions, this field is ignored.

8.13.5.4 Scope-specified address

Parameter in the Scope-specified address field is ignored by the drive.

8.13.5.5 Extent length

Parameter in the Extent length field is ignored by the drive.

8.13.5.6 APTPL

The APTPL (Active Persist Through Power Loss) is valid only for the Register service action. The drive ignores the APTPL in other service actions.

The following table shows the relationship between the last valid APTPL value and information held by the drive.

Information held by the drive	The last valid APTPL value	
	0	1
Registration	all keys are set to 0	retained
Persistent Reservation	all are removed	retained
Generation counter	set to 0	set to 0

Figure 108. APTPL and information held by a drive

8.13.5.7 Generation counter

The drive increments the Generation counter when Register service action or Preempt and Clear service action complete successfully.

8.14 PRE-FETCH (34)

Byte	Bit							
	7	6	5	4	3	2	1	0
0	Command Code = 34h							
1	Reserved = 0			Reserved = 0			Immed = 0	RelAdr = 0
2 3 4 5	(MSB) Logical Block Address (LSB)							
6	Reserved = 0							
7 8	(MSB) Transfer Length (LSB)							
9	VU = 0	Reserved = 0				FLAG	LINK	

Figure 109. Pre-Fetch (34)

The PRE-FETCH command requests the drive to transfer data to the cache. No data is transferred to the initiator.

Transfer length The transfer length field specifies the number of contiguous blocks of data that are to be transferred into the cache. A transfer length of zero indicates that blocks are to be transferred into the cache until the segment is filled or until there are no more blocks on the media.

Immed (Immediate) must be zero. An immediate bit of zero indicates that the status shall not be returned until the operation has completed.

If the Immed bit is set to one, the drive returns a Check Condition status. The sense key shall be set to Illegal Request and the additional sense code shall be set to Invalid Field in CDB.

RelAdr Relative Block Address is not supported. Must be set to zero.

8.15 READ (08)

Byte	Bit							
	7	6	5	4	3	2	1	0
0	Command Code = 08h							
1	Reserved = 0		(MSB)			LBA		
2	Logical Block Address (LSB)							
3								
4	Transfer Length							
5	VU = 0		Reserved = 0			FLAG	LINK	

Figure 110. READ (08)

The READ command requests the drive to transfer the specified number of blocks of data to the initiator starting at the specified logical block address.

Logical block address This field specifies the logical unit at which the read operation shall begin.

Transfer length This field specifies the number of blocks to be transferred. A value of zero implies 256 blocks are to be transferred.

Note: Errors are handled by ERP (error recovery procedure). ERP's are controlled by the error recovery parameters specified by MODE SELECT command.

8.16 READ BUFFER (3C)

Byte	Bit							
	7	6	5	4	3	2	1	0
0	Command Code = 3Ch							
1	Reserved = 0				Mode			
2	Buffer ID = 0							
3	(MSB) Buffer Offset (LSB)							
4								
5								
6	(MSB) Allocation Length (LSB)							
7								
8								
9	VU = 0	Reserved = 0				FLAG	LINK	

Figure 111. READ BUFFER (3C)

The READ BUFFER command is used in conjunction with the WRITE BUFFER command as a diagnostic function for testing the memory of the drive and the SCSI bus integrity. This command does not alter the medium.

The function of this command and the meaning of fields within the command descriptor block depend on the contents of the mode field.

MODE	Description
0000	Read Combined Header and Data
0010	Data
0011	Descriptor
1010	Read Data from Echo Buffer
1011	Echo Buffer Descriptor
All others	Not supported.

8.16.1 Combined Header And Data (Mode 0000b)

In this mode a four byte header followed by data bytes are returned to the initiator during the DATA IN phase. The Buffer ID and the buffer offset field are reserved.

The drive terminates the DATA IN phase when allocation length bytes of header plus data have been transferred or when the header and all available data have been transferred to the initiator, whichever is less.

The four-byte READ BUFFER header (see figure below) is followed by data bytes from the data buffer of the drive.

Byte	Bit							
	7	6	5	4	3	2	1	0
0	RSVD = 0							
1	(MSB) Buffer Capacity (LSB)							
2								
3								

Figure 112. READ BUFFER Header

The buffer capacity specifies the total number of data bytes that are available in the data buffer of the drive. This number is not reduced to reflect the allocation length nor is it reduced to reflect the actual number of bytes written using the WRITE BUFFER command.

Following the READ BUFFER header the drive will transfer data from its data buffer.

8.16.2 Read Data (Mode 0010b)

In this mode, the DATA IN phase contains buffer data.

Buffer ID field must be set to zero, indicating the data transfer buffer. If another value is specified, the command is terminated with CHECK CONDITION status. The drive shall set sense key to ILLEGAL REQUEST and additional sense code to ILLEGAL FIELD IN CDB.

Buffer Offset specifies the offset of the memory space specified by the Buffer ID. The initiator should conform to the offset boundary requirements returned in the READ BUFFER descriptor. If the value exceeds the buffer specified, the command is terminated with CHECK CONDITION status. The drive shall set sense key to ILLEGAL REQUEST and additional sense code to ILLEGAL FIELD IN CDB.

Allocation Length The drive terminates the DATA IN phase when allocation length bytes of data have been transferred or when the header and all available data have been transferred to the initiator, whichever is less.

8.16.3 Descriptor (Mode 0011b)

In this mode, a maximum of four bytes of READ BUFFER descriptor information are returned. The drive returns the descriptor information for the buffer specified by the Buffer ID.

Buffer ID field should normally be set to zero indicating the drive data transfer buffer. If any other value is specified, the drive returns all zeros in the READ BUFFER descriptor.

Buffer Offset field is reserved.

Allocation Length must be set to four or greater. The drive transfers the allocation length or four bytes of READ BUFFER descriptor, whichever is less. The READ BUFFER descriptor is defined in the figure below.

Byte	Bit							
	7	6	5	4	3	2	1	0
0	Offset Boundary							
1	(MSB) Buffer Capacity (LSB)							
2								
3								

Figure 113. Read Buffer Descriptor

The value contained in the Buffer Offset field of subsequent WRITE BUFFER and READ BUFFER commands should be a multiple of two to the power of the offset boundary. The offset boundary is always set to nine, which indicates Sector Boundaries.

8.16.4 Read Data from Echo Buffer (Mode 1010b)

In this mode the drive transfers data from the echo buffer. The echo buffer will transfer the same data as when the Write Buffer command was issued with the mode field set to echo buffer.

Write Buffer command with the mode field set to echo buffer should be sent prior to the Read Buffer command; otherwise the Read Buffer command will be terminated with Check Condition "Illegal Request".

8.16.5 Echo Buffer Descriptor (Mode 1011b)

In this mode, a maximum of four bytes of Read Buffer Descriptor information is returned. The drive returns the descriptor information for the echo buffer. The Buffer Offset field is reserved in this mode and must be zero. The drive transfers the lesser of the allocation length or four bytes of following Echo Buffer Descriptor.

Byte	Bit							
	7	6	5	4	3	2	1	0
0	Reserved = 0							EBOS=0
1	Reserved = 0							
2	Reserved = 0				(MSB) Buffer Capacity			
3	Buffer Capacity				(LSB)			

Figure 114. Echo Buffer Descriptor

EBOS (Echo Buffer Overwritten Supported) bit of zero indicates that the echo buffer is shared by all initiators.

Buffer Capacity field returns the size of the echo buffer in byte aligned to a four-byte boundary.

8.17 READ CAPACITY (25)

Byte	Bit							
	7	6	5	4	3	2	1	0
0	Command Code = 25h							
1	Reserved = 0			Reserved = 0				RelAdr = 0
2 3 4 5	(MSB) Logical Block Address							(LSB)
6 7	Reserved = 0							
8	Reserved = 0							PMI
9	VU = 0		Reserved = 0				FLAG	LINK

Figure 115. READ CAPACITY (25)

The READ CAPACITY command returns information regarding the capacity of the drive.

- **Logical Block Address** is used in conjunction with the PMI bit.
- **RelAdr** A Relative Address is not supported. Must be set to zero.
- **PMI** Partial Medium Indicator indicates

PMI Description

- | | |
|---|---|
| 0 | The drive returns the last logical block address of the drive. |
| 1 | The drive returns the last logical block address and block length in bytes are that of the logical block address after which a substantial delay in data transfer will be encountered. This returned logical block address shall be greater than or equal to the logical block address specified by the logical block address fields in the command descriptor block.

This option provides the information which the initiator needs to determine the amount of space available on the same track which is accessible without a head switch or seek. |

8.17.1 Returned Data Format

The data returned to the initiator in response to the READ CAPACITY command is described here. The data is returned in the DATA IN phase.

Byte	Bit							
	6	7	5	4	3	2	1	0
0	(MSB) Logical Block Address (LSB)							
1								
2								
3								
4	(MSB) Block Length (LSB)							
5								
6								
7								

Figure 116. Format of READ CAPACITY command reply

- **Block Length** specifies the length in bytes of the block.

8.18 READ DEFECT DATA (37)

Byte	Bit							
	7	6	5	4	3	2	1	0
0	Command Code = 37h							
1	Reserved = 0			Reserved = 0				0
2	Reserved = 0			Plist	Glist	Defect List Format		
3	Reserved = 0							
4								
5								
6								
7	(MSB) Allocation Length							(LSB)
8								
9	VU = 0	Reserved = 0				FLAG	LINK	

Figure 117. Read Defect Data (37)

The READ DEFECT DATA command requests that the Target transfer the medium defect data to the initiator.

If the target is unable to access any medium defect data it will return a Check Condition status with the appropriate sense key. The sense key will be set to either Medium Error(03h) if a medium error occurred or No Sense(00h) if the list does not exist and the additional sense code will be set to Defect List Error (19h).

Plist The Primary Defect List (Plist) bit set to one indicates that the target returns the primary list of defects. A Plist bit of zero indicates that the target shall not return the Primary Defect list of defects.

Glist The Grown Defect List (Glist) bit set to one indicates that the target returns the grown defect list. A Glist bit of zero indicates that the target shall not return the Grown Defect list of defects.

Note: With both bits set to one Plist and Glist the target will return both the Primary and Grown defect lists. With both bits set to zero, the target will return only a four-byte Defect List Header.

Defect List format

The Defect List Format Field is used by the initiator to indicate the preferred format for the defect list.

The Defect List Format of '100 (Bytes from Index Format)' and '101 (Physical Sector Format)' are supported. If the requested format is not supported by the drive, it will return the defect list in its default format '101' and then terminate the command with Check Condition status. The sense key will be set to Recovered Error (01h) and the additional sense code will be set to Defect List Not Found(1Ch).

The drive sends defect list (Defect Descriptors) in a four byte ABA (Absolute Block Address) format which follows a four byte Defect List Header.

The target will transfer all of the Read Defect Data up to the number of bytes allocated by the initiator.

Note: The drive will terminate the Data In phase when the Allocation Length has been transferred or when all available Defect Data has been transferred to the initiator, whichever is less.

The Read Defect Data contains a four byte header followed by zero or more defect descriptors.

8.18.1 Defect List Header

Byte	Bit							
	7	6	5	4	3	2	1	0
	Defect List Header							
0	Rsvd = 0							
1	Reserved = 0		Plist	Glist	Defect List Format			
2	(MSB) Defect List length (LSB)							
3								

Figure 118. Defect List Header

8.18.2 Bytes from Index Format (100b)

Byte	Defect Descriptors
0	(MSB) Cylinder Number of Defect (LSB)
1	
2	
3	Head Number of Defect
4	(MSB) Defect Bytes from Index (LSB)
5	
6	
7	

Figure 119. Defect Descriptors of Bytes from Index Format

Defect Bytes from Index is gotten using the following equation:

$$\text{Bytes from Index} = (\text{Physical Sector Number}) * N$$

Where: N = Bytes per sector

8.18.3 Physical Sector Format (101b)

Byte	Defect Descriptors
0	(MSB)
1	Cylinder Number of Defect
2	(LSB)
3	Head Number of Defect
4	(MSB)
5	Defective Sector Number
6	
7	(LSB)

Figure 120. Defect Descriptors of Physical Sector Format

The Defect List Format field specifies the format of the defect list data returned by the target.

The Defect List Length field specifies the length in bytes of the defect descriptors that follow. The Defect List Length is equal to eight times the number of defect descriptors.

Normally the Target will set the Defect List Length field to the amount of space needed to contain the entire defect list. However, the Target is capable of building a defect list with a length such that the entire list cannot be transferred using the maximum allocation length. If the defect list grows beyond 8191 entries, the defect data cannot be transferred with an allocation length of 0FFFFh. The Target will transfer a partial defect list and return Check Condition status with the sense key set to Recovered Error and the Additional Sense Code is set to Partial Defect List Transferred. The defect list length will be set to 0FFF8h, indicating the maximum number of defect descriptors which can be transferred. Defects beyond this number can not be read by the initiator.

8.19 READ DEFECT DATA (B7)

Byte	Bit							
	7	6	5	4	3	2	1	0
0	Command Code = B7h							
1	Reserved = 0		Plist	Glist	Defect List Format			
2	Reserved = 0							
3								
4								
5								
6 9	(MSB)	Allocation Length						(LSB)
10	Reserved = 0							
11	VU = 0		Reserved = 0			FLAG	LINK	

Figure 121. Read Defect Data (B7)

The READ DEFECT DATA command requests that the Target transfer the medium defect data to the initiator.

If the target is unable to access any medium defect data it will return a Check Condition status with the appropriate sense key. The sense key will be set to either Medium Error (03h) if a medium error occurred or to No Sense (00h) if the list does not exist and the additional sense code will be set to Defect List Error (19h).

Plist The Primary Defect List (Plist) bit set to one indicates that the target returns the primary list of defects. A Plist bit of zero indicates that the target shall not return the Primary Defect list of defects.

Glist The Grown Defect List (Glist) bit set to one indicates that the target returns the grown defect list. A Glist bit of zero indicates that the target shall not return the Grown Defect list of defects.

Note: With both bits set to one Plist and Glist the target will return both the Primary and Grown defect lists. With both bits set to zero the target will return only a four-byte Defect List Header.

Defect List format

The Defect List Format Field is used by the initiator to indicate the preferred format for the defect list.

The Defect List Format of '100 (Bytes from Index Format)' and '101 (Physical Sector Format)' are supported. If the requested format is not supported by the drive, it will return the defect list in its default format '101' and then terminate the command with Check Condition status. The sense key will be set to Recovered Error (01h) and the additional sense code will be set to Defect List Not Found (1Ch).

The drive sends defect list (Defect Descriptors) in a four byte ABA (Absolute Block Address) format which follows a four byte Defect List Header.

The target will transfer all of the Read Defect Data up to the number of bytes allocated by the initiator.

Note: The drive will terminate the Data In phase when the Allocation Length has been transferred or when all available Defect Data has been transferred to the initiator, whichever is less.

The Read Defect Data contains a four byte header, followed by zero or more defect descriptors.

8.19.1 Defect List Header

Byte	Bit							
	7	6	5	4	3	2	1	0
	Defect List Header							
0	Rsvd = 0							
1	Reserved = 0		Plist	Glist	Defect List Format			
2	Rsvd = 0							
3	Rsvd = 0							
4	(MSB) Defect List length (LSB)							
5								
7								

Figure 122. Defect List Header

8.19.2 Bytes from Index Format (100b)

Byte	Defect Descriptors
0	(MSB) Cylinder Number of Defect (LSB)
1	
2	
3	Head Number of Defect
4	(MSB) Defect Bytes from Index (LSB)
5	
6	
7	

Figure 123. Defect Descriptors of Bytes from Index Format

Defect Bytes from Index is derived using the following equation:

$$\text{Bytes from Index} = (\text{Physical Sector Number}) * N$$

Where: N = Bytes per sector

8.19.3 Physical Sector Format (101b)

Byte	Defect Descriptors
0	(MSB)
1	Cylinder Number of Defect
2	(LSB)
3	Head Number of Defect
4	(MSB)
5	Defective Sector Number
6	
7	(LSB)

Figure 124. Defect Descriptors of Physical Sector Format

The Defect List Format field specifies the format of the defect list data returned by the Target.

The Defect List Length field specifies the length in bytes of the defect descriptors that follow. The Defect List Length is equal to eight times the number of defect descriptors.

If the Allocation Length is insufficient to transfer all of the defect descriptors, the Defect List Length will not be adjusted to reflect the truncation. The Target will not create a CHECK CONDITION status.

8.20 READ EXTENDED (28)

Byte	Bit							
	7	6	5	4	3	2	1	0
0	Command Code = 28h							
1	Reserved = 0		DPO	FUA	Reserved = 0		RelAdr = 0	
2	(MSB) Logical Block Address (LSB)							
3								
4								
5								
6	Reserved = 0							
7	(MSB) Transfer Length (LSB)							
8								
9	VU = 0	Reserved = 0				FLAG	LINK	

Figure 125. Read Extended (28)

The READ EXTENDED command requests the drive to transfer data to the initiator. The larger Logical Block Address and Transfer Length fields permit greater quantities of data to be requested per command than with the READ command and are required to access the full LBA range of the larger capacity drives.

Transfer length The number of contiguous blocks to be transferred. If the transfer length is zero, the seek occurs, but no data is transferred. This condition is not considered an error. If read ahead is enabled, a read ahead is started after the seek completes.

DPO A DPO (Disable Page Out) bit of one indicates that the data accessed by this command is to be assigned the lowest priority for being written into or retained by the cache. A DPO bit of one overrides any retention priority specified in the Mode Select Page 8 Caching Parameters. A DPO bit of zero indicates the priority is determined by the retention priority. The initiator should set the DPO bit when the blocks read by this command are not likely to be read again in the near future.

FUA Force Unit Access. A FUA bit of one indicates that the data is read from the media and not from the cache. A FUA bit of zero allows the data to be read from either the media or the cache.

RelAdr Relative Block Address is not supported. Must be set to zero.

8.21 READ LONG (3E)

Byte	Bit							
	7	6	5	4	3	2	1	0
0	Command Code = 3Eh							
1	Reserved = 0			Reserved = 0			CORT = 0	RelAdr = 0
2 3 4 5	(MSB) Logical Block Address (LSB)							
6	Reserved = 0							
7 8	(MSB) Byte Transfer Length (LSB)							
9	VU = 0	Reserved = 0				FLAG	LINK	

Figure 126. READ LONG (3E)

The READ LONG command requests the drive to transfer one block of data to the initiator. The transfer data includes data and ECC field data.

- **CORT** bit of ZERO causes the logical block to be read without any correction made by the drive. A CORT bit of one is not supported by the Target. (A corrected bit of one causes the data to be corrected by ECC before transferring the data to the initiator.)
- **Logical Block Address** field specifies the logical block at which the read operation shall occur.
- **Byte Transfer Length**. This field must specify exactly the number of bytes of data that are available for transfer. If a non-zero byte transfer length does not match the available data length, the target terminates the command with CHECK CONDITION status, the sense key is set to ILLEGAL REQUEST, and an additional sense code set to INVALID FIELD IN CDB. The valid and ILI bits is set to one and the information field is set to the difference of the requested length minus the actual length in bytes. Negative values are indicated by two's complement notation.

The transfer length is calculated as follows:

$$\text{transfer length} = \text{logical block size} + 40$$

- **RelAdr** Relative Block Address is not supported by the drive.

8.22 REASSIGN BLOCKS (07)

Byte	Bit							
	7	6	5	4	3	2	1	0
0	Command Code = 07h							
1	Reserved = 0				Reserved = 0			
2	Reserved = 0							
3								
4								
5	VU = 0	Reserved = 0				FLAG	LINK	

Figure 127. REASSIGN BLOCKS (07)

The REASSIGN BLOCKS command requests the drive to reassign a logical block to an available spare. The REASSIGN BLOCKS command attempts to allocate spare blocks on a spare track. The logical block address is transferred to the drive during the DATA OUT phase. One to four block(s) may be specified for relocation per REASSIGN BLOCKS command.

Reassignment is complete upon the completion of the REASSIGN BLOCKS command. At this time, the defective logical block address has been added to the grown (“G” list) defect list.

Data contained at the logical block address being reassigned is not preserved by the drive and is filled with a constant pattern.

Following is the format of the data sent by the initiator during the DATA OUT phase

Byte	Bit							
	7	6	5	4	3	2	1	0
0	RSVD = 0							
1	RSVD = 0							
2 3	(MSB) Defect list length = 4/8/12/16 (LSB)							
4 5 6 7	(MSB) Defect Logical Block Address -1 (LSB)							
8 9 10 11	(MSB) Defect Logical Block Address -2 (LSB)							
12 13 14 15	(MSB) Defect Logical Block Address -3 (LSB)							
16 17 18 19	(MSB) Defect Logical Block Address -4 (LSB)							

Figure 128. Format of REASSIGN BLOCKS data

Note: If the drive finds a defective block by verifying ECC before it finds a spare, the drive will not start the REASSIGN BLOCKS process but will return CHECK CONDITION status with sense key set to MEDIUM ERROR.

- **Defect List Length** must be 4,8,12, or 16. Otherwise, the drive returns Check Condition with Sense key = Illegal request.
- **Defective Logical Block Address** is 4 bytes in length. The initiator can specify from 1 to 4 Defective Logical Block Address according to the Defect List Length from 4 to 16, respectively. Defective Logical Block Addresses must be ordered in ascending order, otherwise the drive returns Check Condition.

8.23 RECEIVE DIAGNOSTICS (1C)

Byte	Bit							
	7	6	5	4	3	2	1	0
0	Command Code = 1Ch							
1	Reserved = 0			Reserved = 0				PCV
2	Page Code							
3	(MSB) Parameter List Length							(LSB)
4								
5	VU = 0		Reserved = 0				FLAG	LINK

Figure 129. RECEIVE DIAGNOSTIC (1C)

The Receive Diagnostic command requests that analysis data requested by a Send Diagnostics command be sent to the initiator.

- **PCV** (Page Code Valid) bit of zero indicates that the most recent SEND DIAGNOSTIC command shall define the data returned by this command. PCV bit of one indicates that the contents of the Page Code field shall define the data returned by this command.
- **Parameter List Length** specifies the amount of data to be returned to the initiator. This value may be zero and this is not considered an error. The target terminates the Data In phase when all available data has been transferred or when the number of bytes transferred equals the Parameter List Length.

8.23.1 Receive Diagnostic Page 0

This page contains a list of supported pages.

Byte	Bit							
	7	6	5	4	3	2	1	0
0	Page Code = 0							
1	Reserved = 0							
2-3	Page Length = 03h							
4	First supported page 0h							
5	Second supported page 40h							
6	Third supported page 80h							

Figure 130. Receive Diagnostic page 0

8.23.2 Receive Diagnostic Page 40

Using the Send Diagnostics command, an address in either physical or logical format is supplied to the drive. This page is then used to retrieve the address translated into the other format.

Byte	Bit							
	7	6	5	4	3	2	1	0
0	Page Code = 40h							
1	Reserved = 0							
2-3	Page Length = 0Ah							
4	Reserved = 0					Supplied format		
5	RA	ALTS	ALTT	Reserved=0		Translate format		
6 - 13	Translated Address							

Figure 131. Receive Diagnostic Page 40

- **Supplied Format** is the value supplied by the Send Diagnostic command; it may be one of the three following values:
 - **000b** Block format
 - **100b** Bytes From Index format
 - **101b** Physical Sector format

It specifies the format in which the address has been supplied.

- **Translate Format** is the value supplied by the Send Diagnostic command and specifies the format in which the address has been translated into List. If the supplied format is the Block format, the Translate format must be either Bytes from Index or Physical Sector format. If the supplied format is the Bytes from Index or Physical Sector format, the Translate format must be Block format. Otherwise the Target will terminate the command with Check Condition status.
- **RA (Reserved Area)** is set to one if the translated block is a reserved area.
- **ALTS (Alternate Sector)** is set to one if the translated block is in alternate sector area.
- **ALTT (Alternate Track)** is set to one if the translated block is in alternate track area. This bit is not used by the drive.

- **Translated Address** contains the address in the translate format. If it is a logical block address, it is contained within the first 4 bytes of the field (bytes 6 to 9) of the page data. For a physical format it is as follows:

Byte	Bit							
	7	6	5	4	3	2	1	0
6-8	Cylinder Number							
9	Head Number							
0-13	Sector Number or Bytes from Index							

Figure 132. Translated address

8.23.3 Receive Diagnostic Page 80

This page contains the off-line read scan status.

Byte	Bit							
	7	6	5	4	3	2	1	0
0	Page Code = 80h							
1	Reserved = 0							
2-3	Page Length = 04h							
4	SMART Revision = 03h							
5	Off-line Read Scan Ratio							
6 7	(MSB) Estimated Completion Time							

Figure 133. Receive Diagnostic Page 80

- **Off-line Read Scan Ration** indicates the progress of the read scan activity. The number is the numerator of a fraction whose denominator is 100.
- **Estimated Completion Time** indicates the total time in seconds to complete a full read scan without interruption.

8.24 RELEASE (17)

Byte	Bit							
	7	6	5	4	3	2	1	0
0	Command Code = 17h							
1	Reserved = 0		3rdPty	3rd Party ID			Ext=0	
2	Reservation Identification							
3	Reserved = 0							
4								
5	VU = 0		Reserved = 0			FLAG	LINK	

Figure 134. RELEASE (17)

The RELEASE command is used to release a LUN previously reserved.

Note: It is not an error for an initiator to release a LUN that is not currently reserved.

- **3rdPty** bit indicates that
 - 1 this release process is for a third party which is specified by 3rd Party ID.
 - 0 this release process is for the initiator itself.
- **3rd Party ID** specifies the ID of the third party for which the LUN is reserved.⁴
- **Extents** must be 0. Extension is not supported by the drive.
- **Reservation Identification** field is ignored.

⁴ Refer to 8.29 "Reserve (16)*" on page 156.

8.25 RELEASE (57)

Byte	Bit							
	7	6	5	4	3	2	1	0
0	Command Code = 57h							
1	Reserved = 0		3rdPty	Reserved = 0			Ext = 0	
2	Reservation Identification							
3	3rd Party Device ID							
4	Reserved = 0							
5	Reserved = 0							
6	Reserved = 0							
7	Reserved = 0							
8	Reserved = 0							
9	VU = 0		Reserved = 0			FLAG	LINK	

Figure 135. RELEASE (57)

The Release command is used to release a LUN previously reserved. It is not an error for an Initiator to attempt to release a reservation that is not currently active. In this case the drive returns Good status without altering the reservation.

Extents are not supported by the drive. The Ext (Extent) bit must be zero and the Reservation Identification field is ignored. If the Ext bit is not zero, Check Condition Status is returned with a Sense Key of Illegal Request and additional sense code of Invalid Field in CDB.

If the 3rdPty bit is zero, then the third-party release option is not requested. If the 3rdPty bit is one, then the Target releases the LUN, but only if the reservation was made using the third-party reservation option and the 3rd Party ID is the ID of the initiator that made the reservation

8.26 REPORT DEVICE IDENTIFIER (A3)

Byte	Bit							
	7	6	5	4	3	2	1	0
0	Command Code = A3h							
1	Reserved = 0				Service Action = 05h			
2	Reserved = 0							
3	Reserved = 0							
4 5	(MSB)		LUN				(LSB)	
6 9	(MSB)		Allocation Length				(LSB)	
10	Reserved = 0							
11	VU = 0		Reserved = 0			FLAG	LINK	

Figure 136. REPORT DEVICE IDENTIFIER(A3)

The REPORT DEVICE IDENTIFIER command requests that the device server send device identification information to the application client.

The LUN contains the logical unit number. If the requested logical unit has not been added to the target, the command is terminated with a CHECK CONDITION status. The sense key is set to ILLEGAL REQUEST, and the additional sense code set to LOGICAL UNIT NOT SUPPORTED.

The ALLOCATION LENGTH field indicates how much space has been reserved for the returned parameter data. If the length is not sufficient to contain all the parameter data, the first portion of the data is returned. This is not considered an error. The actual length of the parameter data is available in the IDENTIFIER LENGTH field in the parameter data. If the remainder of the parameter data is required, the application client should send a new REPORT DEVICE IDENTIFIER command with an ALLOCATION LENGTH field large enough to contain all the data.

The REPORT DEVICE IDENTIFIER parameter list contains a four-byte field that contains the length in bytes of the parameter list and the logical unit's identifier.

Byte	Bit							
	7	6	5	4	3	2	1	0
0 3	(MSB) Identifier Length = n-3 (LSB)							
4 n	Identifier							

Figure 137. REPORT DEVICE IDENTIFIER parameter list

The IDENTIFIER LENGTH field specifies the length in bytes of the IDENTIFIER field. If the ALLOCATION LENGTH field in the CDB is too small to transfer all of the identifier, the length is not adjusted to reflect the truncation. The identifier length initially equals zero, and is changed only by a successful SETDEVICE IDENTIFIER command.

The IDENTIFIER field contains a vendor specific value. The value reported is the last value written by a successful SET DEVICE IDENTIFIER command. The value of the identifier is changed only by a SET DEVICE IDENTIFIER command. The identifier value persist through resets, power cycles, media format operations.

The target return the same Identifier to all initiators on all ports.

The execution of a REPORT DEVICE IDENTIFIER requires the enabling of a nonvolatile memory within the logical unit. If the nonvolatile memory is not ready, the device server return CHECK CONDITION status, rather than wait for the device to become ready. The sense key is set to NOT READY and the additional sense data is set as described in the TEST UNIT READY command. This information should allow the application client to determine the action required to cause the device server to become ready.

8.27 REPORT LUN (A0)

Byte	Bit							
	7	6	5	4	3	2	1	0
0	Command Code = A0h							
1 5	Reserved							
6 9	(MSB)	Allocation Length						(LSB)
10	Reserved							
11	VU = 0	Reserved = 0				FLAG	LINK	

Figure 138. REPORT LUN (A0)

The Report LUN's command requests that the target return the known Logical Unit Numbers (LUN) to the initiator. The Report LUN's command should always be available and is unaffected by any reservations.

The Allocation Length must be at least 16 bytes. If the Allocation Length is less than 16 bytes, the target will return in Check Condition Status with Sense Key of Illegal Request and additional Sense Code of Invalid Field in CDB. If the Allocation Length is not sufficient to contain the Logical Unit Number values for all configured logical units, the target shall report as many logical unit number values as will fit in the specified Allocation Length. This is not considered an error.

The Report LUN's command will send the LUN List in the subsequent Data Out Phase. The format of the LUN List is shown in the following table.

Byte	Bit							
	7	6	5	4	3	2	1	0
0 3	(MSB)	LUN List Length = 8						(LSB)
4 7	Reserved							
8 15	(MSB)	LUN = 0						(LSB)

Figure 139. LUN Reporting Parameter List Format

The LUN list length shall contain the length in bytes of the LUN list that is available to be transferred. This product only supports one LUN. Therefore, the LUN list length must be set to 8. The only supported LUN is zero.

8.28 REQUEST SENSE (03)

Byte	Bit							
	7	6	5	4	3	2	1	0
0	Command Code = 03h							
1	Reserved = 0			Reserved = 0				
2	Reserved = 0							
3								
4	Allocation Length							
5	VU = 0		Reserved = 0			FLAG	LINK	

Figure 140. REQUEST SENSE (03)

The REQUEST SENSE command requests the drive to transfer sense data.

The sense data shall be available under the following conditions:

- The previous command to the specified I_T_L⁵ nexus terminated with CHECK CONDITION status. An other information (e.g. medium position) is available in any fields.
- The previous command to the specified I_T_L nexus ended unexpected BUS FREE error.

If REQUEST SENSE command with an invalid LUN is received, the drive returns GOOD status and reports a sense key of ILLEGAL REQUEST and an additional sense code of LOGICAL UNIT NOT SUPPORTED.

If the drive has no sense data available to return, it shall return a sense key of NO SENSE and an additional sense code of NO ADDITIONAL SENSE INFORMATION.

The sense data shall be preserved by the drive for the initiator until retrieved by the REQUEST SENSE command or until any other command for the same I_T_L nexus. Sense data shall be cleared upon receiving a subsequent command including REQUEST SENSE to the same I_T_L nexus.

Separate sense data is maintained by the device for each initiator. Therefore, there is no requirement for an initiator to expeditiously clear a CHECK CONDITION as this will not affect other initiators in a multi-initiator system.

The drive will return the number of bytes in the allocation length or 32 bytes whichever is less.

The contents of the sense data is defined in **SCSI Sense Data** on page 209.

⁵ A nexus which exists between an initiator, a target, and a logical unit.

8.29 RESERVE (16)

Byte	Bit							
	7	6	5	4	3	2	1	0
0	Command Code = 16h							
1	Reserved = 0		3rdPty	3rd Party ID			Ext = 0	
2	Reservation Identification							
3	(MSB) Extent List Length = 0				(LSB)			
4								
5	VU = 0		Reserved = 0			FLAG	LINK	

Figure 141. RESERVE (16)

The RESERVE command is used to reserve a LUN for an initiator. This reservation can be either for the initiator which sends this command or for the third party which is specified in this command.

This command results in reserving the entire LUN for the initiator until one of the following occurs:

- The reservation is superseded by another valid RESERVE command from the initiator that made the reservation.
- The LUN is released by a RELEASE command from the same initiator.
- A hard reset condition occurs. (A SCSI bus Reset assertion).
- A BUS DEVICE RESET message is received from any initiator.
- Power off/on occurs.

3rdPty bit is to indicate that

- 1** this reservation is for a third party which is specified by 3rd Party ID.
- 0** this reservation is for the initiator itself.

3rd Party ID specifies the ID of the third party for which the LUN is reserved.

Note: The LUN may be only released by the initiator who sent the RESERVE command.

Extents must be 0. Extension is not supported by the drive.

Reservation Identification is ignored.

Extent List length must be zero. Extent List length is not supported.

8.30 RESERVE (56)

Byte	Bit							
	7	6	5	4	3	2	1	0
0	Command Code = 57h							
1	Reserved = 0		3rdPty	Reserved			Ext = 0	
2	Reservation Identification							
3	Third Party Device ID							
4	Reserved = 0							
5	Reserved = 0							
6	Reserved = 0							
7	(MSB) Extent List Length = 0							(LSB)
8								
9	VU = 0		Reserved = 0			FLAG	LINK	

Figure 142. RESERVE (56)

The Reserve command is used to reserve a LUN for an Initiator. This reservation can be either for the Initiator sending the command or for a third party as specified by the Initiator.

Extents are not supported by the drive. The Ext bit must be zero. If Ext bit is set to one, Check Condition Status is returned with a Sense Key of Illegal Request and additional sense code of Invalid Field in CDB. The Reservation Identification and Extent List Length fields are ignored.

The Reserve command requests that the entire Lun be reserved for the Initiator until

- the reservation is superseded by another valid Reserve command from the Initiator that made the reservation.
- the reservation is released by a Release command from the same Initiator.
- a hard Reset condition occurs.
- a Bus Device Reset message is received from any Initiator.
- a power off/on cycle occurs.

The 3rdPty bit of zero indicates that the Initiator that issued the Reserve command is the Initiator for which the LUN is reserved.

The 3rdPty bit of one indicates that this is a third-party reservation. The 3rd Party ID byte specifies the ID of the third party for which the LUN is reserved. A reservation made with the 3rdPty bit of one and the 3rd Party ID byte set to the Initiator that issued this Reserve command is considered equivalent to a reservation made with the 3rdPty bit set to zero.

Only the Initiator that issued the Reserve command for a LUN may release the LUN, regardless of the 3rdPty option. This Initiator may also release the LUN by issuing another Reserve command. This superseding Reserve command releases the previous reservation when the new reservation is granted.

Reservation queuing is not supported by the drive. If a LUN is reserved and a Reserve command is issued from a different initiator, the Target responds with a reservation Conflict.

8.31 REZERO UNIT (01)

Byte	Bit							
	7	6	5	4	3	2	1	0
0	Command Code = 01h							
1	Reserved = 0			Reserved = 0				
2 3 4	Reserved = 0							
5	VU = 0		Reserved = 0			FLAG	LINK	

Figure 143. REZERO UNIT (01)

The REZERO UNIT command requests that the target seek logical block address 0.

8.32 SEEK (0B)

Byte	Bit							
	7	6	5	4	3	2	1	0
0	Command Code = 0Bh							
1	Reserved = 0		(MSB)		LBA			
2	Logical Block Address (LSB)							
3								
4	Reserved = 0							
5	VU = 0		Reserved = 0			FLAG	LINK	

Figure 144. SEEK (0B)

The SEEK command requests the drive to seek the specified logical block address.

8.33 SEEK EXTENDED (2B)

Byte	Bit							
	7	6	5	4	3	2	1	0
0	Command Code = 2Bh							
1	Reserved = 0			Reserved = 0				0
2	(MSB) Logical Block Address (LSB)							
3								
4								
5								
6	Reserved = 0							
7								
8								
9	VU = 0		Reserved = 0			FLAG	LINK	

Figure 145. SEEK EXTENDED (2B)

The SEEK EXTENDED command requests the drive to seek the specified logical block address.

8.34 SEND DIAGNOSTIC (1D)

Byte	Bit							
	7	6	5	4	3	2	1	0
0	Command Code = 1Dh							
1	Function Code		PF	RSVD=0	SIfTst	Dev0fl	Unt0fl	
2	Reserved = 0							
3	(MSB) Parameter List Length (LSB)							
4								
5	VU = 0		Reserved = 0			FLAG	LINK	

Figure 146. SEND DIAGNOSTIC (1D)

The SEND DIAGNOSTIC command requests the drive to perform its self-diagnostic test or to perform a function based on a page of information sent in a Data Out phase during the command.

- **PF (Page Format)** bit set to one indicates the data sent by the Initiator conform to the page structure as specified in SCSI-2 standard. This bit must be set to one if the SIfTst bit is set to zero. This bit is ignored by the Target if the SIfTst bit is set.
- **SIfTst** set to one indicates that the device performs its internal self test when Function code field is 000b. If set to zero, the content of Function code is specified in Function code field values.

Value	Function Name	Description
000b	NA	Value to be used when the slfTst bit is set to one or if The SEND DIAGNOSTIC command is not invoking one of the other self-test function codes.
001b	Background Short self-test	The device server starts its short self-test routine in background mode.
010b	Background extended self-test	The device server starts its extended self-test routine in background mode.
011b	NA	Reserved
100b	Abort background self-test	Abort the current self-test in the background mode. This value is only valid if a previous SEND DIAGNOSTIC command specified a background self-test function and that function has not been completed.
101b	Foreground short self-test	The device server starts its short self-test routine in the foreground mode.
110b	Foreground extended self-test	The device server starts its extended self-test routine in the foreground mode.
111b		Reserved

Figure 147. SEND DIAGNOSTIC (1D)

- **DevOfI** is ignored by the target for compatibility.
- **UntOfI** is ignored by the target for compatibility.
- **Parameter List Length** is ignored by the Target if the SlfTst bit is set. Otherwise it should be set to the length of the page to be transferred in the Data Out phase of the command. If it does not match the expected length of the page a CHECK CONDITION status will be generated with a Sense Key of Illegal Request and additional sense of Invalid Field in CDB.

If the SlfTst bit is set upon command completion, the following status is returned:

- GOOD status for successful test completion.
- CHECK CONDITION status for unsuccessful test completion.

The self diagnostics consists of two parts⁶:

- The first part is executed immediately after power up. This test is performed to verify all hardware which is not related to the disk drive. The local microprocessor, RAM (scratch pad and buffer), and control electronics are included here.

⁶ See 11.18.2, "Diagnostics Command" on page 222 for a detailed listing of the operations carried out by the Diagnostics Command.

- The second part is executed after the spindle motor is started. This includes disk access (seek), R/W channel, and error correction circuitry verification. A reserved area on the disk is used for this test.

Both tests are performed as a result of the SEND DIAGNOSTIC command. The SEND DIAGNOSTICS will fail with CHECK CONDITION status if it is issued while the spindle motor is not turning. (Such as after STOP command has been received.)

Note: The self diagnostic is also performed at Power On Reset time.

Note: The SCSI bus signals will not be corrupted when the device is executing the SEND DIAGNOSTIC command.

8.34.1 Send Diagnostic Page 0

This page requests that the drive return a list of supported pages on the next receive diagnostics command.

Byte	Bit							
	7	6	5	4	3	2	1	0
0	Page Code = 0							
1	Reserved = 0							
2 - 3	Page Length = 0							

Figure 148. Diagnostic Page 0

8.34.2 Send Diagnostic Page 40

This allows the initiator to translate a logical block address or physical sector address to the other format. The address to be translated is passed to the target with the Send Diagnostic command and the results are returned to the initiator by the Receive Diagnostics command.

The target will read the parameter list from the initiator and, if no errors are detected in the parameter list, Good Status will be returned. The data translation will be performed upon receipt of the Receive Diagnostics command.

Byte	Bit							
	7	6	5	4	3	2	1	0
0	Page Code = 40h							
1	Reserved = 0							
2-3	Page Length = 0Ah							
4	Reserved = 0					Supplied format		
5	Reserved = 0					Translate format		
6-13	Address to Translate							

Figure 149. Diagnostic Page 40

Supplied Format may take one of the following three values:

- **000b** Block format
- **100b** Bytes From Index format
- **101b** Physical Sector format

It specifies the format in which the address has been supplied.

- **Translate Format** specifies the format that the address should be translated into. If the supplied format is the Block format, the Translate format must be either Bytes from Index or Physical Sector format. If the supplied format is the Bytes from Index or Physical Sector format, the Translate format must be Block format. If either of the format fields is invalid or they specify the same format, the command will terminate with CHECK CONDITION status with a Sense of Illegal Request and Illegal Field in Parameter List.
- **Address to Translate** contains the address to translate. If the logical block format is specified, the first 4 bytes of the field (bytes 6 to 9) contain the LBA and the remainder must be zero. For the physical format the address must be specified as follows.

Byte	Bit							
	7	6	5	4	3	2	1	0
6-8	Cylinder Number							
9	Head Number							
10-13	Sector Number or Bytes from Index							

Figure 150. Address to translate

8.34.3 Send Diagnostic Page 80

This requests the drive to perform off-line read scan.

Byte	Bit							
	7	6	5	4	3	2	1	0
0	Page Code = 80h							
1	Reserved = 0							
2-3	Page Length = 04h							
4	SMART Revision = 03h							
5	Reserved = 0							
6	(MSB) Off-line Immediate Time							(LSB)
7								

Figure 151. Send Diagnostic Page 80

- **Off-line Immediate Time** specifies the delay to start off-line read scan in seconds. When this value is zero, the target starts off-line read scan immediately.

8.35 SET DEVICE IDENTIFIER (A4)

Byte	Bit							
	7	6	5	4	3	2	1	0
0	Command Code = A4h							
1	Reserved = 0				Service Action = 06h			
2	Reserved = 0							
3								
4								
5								
6 9	(MSB) Parameter List Length (LSB)							
10	Reserved = 0							
11	VU = 0	Reserved = 0				FLAG	LINK	

Figure 152. SET DEVICE IDENTIFIER(A4)

The SET DEVICE IDENTIFIER command requests that the device identifier information be set to the value received in the SET DEVICE IDENTIFIER parameter list.

On successful completion of a SET DEVICE IDENTIFIER command a unit attention is generated for all initiators except the one that issued the service action. When reporting the unit attention condition the additional sense code is set to DEVICE IDENTIFIER CHANGED.

- **Parameter List Length** field specifies the length in bytes of the Identifier that is transferred from the host system to the target. The maximum value for this field is 512 bytes. A parameter list length of zero indicates that no data is transferred, and that subsequent REPORT DEVICE IDENTIFIER commands return an Identifier length of zero.

The SET DEVICE IDENTIFIER parameter list contains the identifier to be set by the addressed logical unit.

Byte	Bit							
	7	6	5	4	3	2	1	0
0 n	Identifier							

Figure 153. SET DEVICE IDENTIFIER Parameter List

The IDENTIFIER field is a vendor specific value, to be returned in subsequent REPORT DEVICE IDENTIFIER commands.

8.36 START/STOP Unit (1B)

Byte	Bit							
	7	6	5	4	3	2	1	0
0	Command Code = 1Bh							
1	Reserved = 0			Reserved = 0				Immed
2 3	Reserved = 0							
4	Power Conditions = 0			Reserved = 0		LoEj = 0	Start	
5	VU = 0		Reserved = 0			FLAG	LINK	

Figure 154. START/STOP Unit (1B)

The START/STOP UNIT command is used to spin up or stop the spindle motor.

- **Immed** bit is to specify
 - 0** status is to be returned at the end of the operation
 - 1** GOOD status shall always be returned immediately after command has been received. The TEST UNIT READY command may be used to determine when the drive becomes ready after a spin-up.
- **Power Conditions** is not supported by the drive and must be set to 0.
- **LoEj** is not supported by the drive and must be set to 0.
- **Start** bit is to specify:
 - 0** stop the spindle
 - 1** start the spindle

Note: Once the drive has become ready (after a power on), the Start/Stop UNIT command can be used without any errors regardless of the state of the motor: stopped or spinning.

8.37 SYNCHRONIZE CACHE (35)

Byte	BIT							
	7	6	5	4	3	2	1	0
0	Command Code = 35h							
1	Reserved = 0		Reserved = 0			Immed = 0	RelAdr = 0	
2 3 4 5	(MSB) Logical Block Address (LSB)							
6	Reserved = 0							
7 8	(MSB) Number of Blocks (LSB)							
9	VU = 0	Reserved = 0				FLAG	LINK	

Figure 155. SYNCHRONIZE CACHE (35)

The SYNCHRONIZE CACHE Command ensures that logical blocks in the cache have their most recent data value recorded on the media.

- **Logical Block Address** is to specify where the operation is to begin.
- **Number of Blocks** specifies the total number of contiguous logical blocks within the range. Number of Blocks of zero indicates that all remaining logical blocks on the logical unit shall be within the range.
- **Immed** (immediate) must be zero. An immediate bit of zero indicates that the status shall not be returned until the operation has completed. If the Immed bit is set to one, the drive returns a Check Condition status. The sense key shall be set to Illegal Request and the additional sense code shall be set to Invalid Field in CDB.
- **RelAdr** (Relative Address) must be zero. The drive does not support the relative addressing. If the RelAdr bit is set to one, the drive returns Check Condition status. The sense key shall be set to Illegal Request and the additional sense code shall be set to Invalid Field in CDB.

8.38 TEST UNIT READY (00)

Byte	Bit							
	7	6	5	4	3	2	1	0
0	Command Code = 00h							
1	Reserved = 0			Reserved = 0				
2	Reserved = 0							
3								
4								
5	VU = 0	Reserved = 0				FLAG	LINK	

Figure 156. TEST UNIT READY (00)

The TEST UNIT READY command allows the initiator to check if the drive is READY. The SCSI specification defines READY as the condition where the device will accept a media-access command without returning CHECK CONDITION status.

The drive will first verify that the motor is spinning at the correct speed. If the spindle motor is not spinning at the correct speed, CHECK CONDITION status is returned with sense key of NOT READY. If the motor is spinning at the correct speed, the drive accepts normal media access commands.

The TEST UNIT READY command is not intended as a diagnostic. No self diagnostic is performed by the device as a result of this command.

The TEST UNIT READY command has special significance for power sequencing using the START UNIT command with an Immediate bit of one. In this mode the START UNIT command returns COMMAND COMPLETE status before the completion of motor spin-up and expects the initiator to issue TEST UNIT READY commands to determine when the motor has reached the proper speed.

Note: The spindle automatically starts in automatic spin-up Mode. The drive does not execute any commands other than TEST UNIT READY, INQUIRY, or REQUEST SENSE command until the Power On sequence is complete. The drive will return CHECK CONDITION status with NOT READY sense key and IN PROCESS OF BECOMING READY sense code for all other commands during the Power On period.

8.39 VERIFY (2F)

Byte	Bit							
	7	6	5	4	3	2	1	0
0	Command Code = 2Fh							
1	Reserved = 0						Byte Chk= 0	RSVD =0
2	(MSB) Logical Block Address (LSB)							
3								
4								
5								
6	Reserved = 0							
7	(MSB) Transfer Length (LSB)							
8								
9	VU = 0	Reserved = 0				FLAG	LINK	

Figure 157. VERIFY (2F)

The VERIFY command requests that the drive verify the data written on the media. A verification length of zero indicates that no data will be transferred. This condition is not considered an error.

ByteChk is not supported and must be 0.

8.40 WRITE (0A)

Byte	Bit							
	7	6	5	4	3	2	1	0
0	Command Code = 0Ah							
1	Reserved = 0		(MSB) LBA					
2	Logical Block Address (LSB)							
3								
4	Transfer Length							
5	VU = 0		Reserved = 0			FLAG	LINK	

Figure 158. WRITE (0A)

The WRITE command requests the drive to write the specified number of blocks of data from the initiator to the medium starting at the specified logical block address.

See **READ (08)** on page 139 for the parameters.

8.41 WRITE AND VERIFY (2E)

Byte	Bit							
	7	6	5	4	3	2	1	0
0	Command Code = 2Eh							
1	Reserved = 0		DPO	Reserved = 0		Byte Chk	RelAdr = 0	
2	(MSB) Logical Block Address (LSB)							
3								
4								
5								
6	Reserved = 0							
7	(MSB) Transfer Length (LSB)							
8								
9	VU = 0	Reserved = 0				FLAG	LINK	

Figure 159. WRITE AND VERIFY (2E)

WRITE AND VERIFY command requests that the drive writes the data transferred from the initiator to the medium and then verify that the data is correctly written.

- **Transfer Length** of zero indicates that no data is transferred.

If caching is enabled, the command performs an implied Force Unit Access (FUA) and an implied Synchronize Cache before starting the operation. This insures that the medium, not the cache, is being verified.

- **ByteChk** bit set to zero indicates that the data is read back from the disk and verified using ECC after the successful write operation. If an ECC error is detected in the verify process, CHECK CONDITION status is returned with sense key set to MEDIUM ERROR. ByteChk bit set to one indicates that byte-by-byte comparison is performed between data on the disk starting the block specified in LBA field and data transferred from the initiator.

If the comparison is unsuccessful, the command is terminated with CHECK CONDITION status and the sense key is set to MISCOMPARE.

- **DPO** (Disable Page Out) bit of one indicates that the data written by this command is to be assigned the lowest priority for being written into or retained by the cache. A DPO bit of one overrides any retention priority specified in the Mode Select Page 8 Caching parameters. A DPO bit of zero indicates the priority is determined by the retention priority.

The initiator should set the DPO bit when the blocks written by this command are not likely to be read again in the near future.

- **Relative Block Address** is not supported. Must be set to zero.

8.42 WRITE BUFFER (3B)

Byte	Bit							
	7	6	5	4	3	2	1	0
0	Command Code = 3Bh							
1	Reserved = 0				Mode			
2	Buffer ID							
3	(MSB) Buffer Offset (LSB)							
4								
5								
6	(MSB) Parameter List Length (LSB)							
7								
8								
9	VU = 0	Reserved = 0				FLAG	LINK	

Figure 160. WRITE BUFFER (3B)

The WRITE BUFFER command is used in conjunction with the READ BUFFER command as a diagnostic function for testing the memory of the drive and the SCSI bus integrity. This command does not alter the medium of the drive. Additional modes are provided for downloading microcode and for downloading and saving microcode.

This command will cause the entire cache to be emptied.

The function of this command and the meaning of fields within the command descriptor block depend on the contents of the mode field.

MODE	Description
0000	Write combined header and data
0010	Data
0100	Download Microcode
0101	Download Microcode and Save
1010	Write Data to Echo Buffer

No other modes are supported by the drive.

8.42.1 Combined Header And Data (Mode 0000b)

In this mode, the data to be transferred is preceded by a four-byte header.

Buffer ID must be zero. If another value is specified, no download function is performed and the command is terminated with CHECK CONDITION status. And the drive shall set the sense key to ILLEGAL REQUEST and additional sense code to ILLEGAL FIELD IN CDB.

Buffer Offset must be zero. If another value is specified, no download function is performed and the command is terminated with CHECK CONDITION status. And the drive shall set the sense key to ILLEGAL REQUEST and additional sense code to ILLEGAL FIELD IN CDB.

Parameter List Length specifies the number of bytes that shall be transferred during the DATA OUT phase. This number includes four bytes of header, so the data length to be stored in the drive buffer is transfer length minus four. If the length exceeds the buffer size, the command is terminated with CHECK CONDITION status. And the drive shall set sense key to ILLEGAL REQUEST and additional sense code to ILLEGAL FIELD IN CDB.

The four-byte header consists of all reserved bytes.

Byte	Bit							
	7	6	5	4	3	2	1	0
0	Reserved = 0							
1	Reserved = 0							
2	Reserved = 0							
3	Reserved = 0							

Figure 161. WRITE BUFFER Header

8.42.2 Write Data (Mode 0010b)

In this mode, the DATA OUT phase contains buffer data.

Buffer ID must be set to zero, indicating the data transfer buffer. If another value is specified, the command is terminated with CHECK CONDITION status. The drive shall set the sense key to ILLEGAL REQUEST and additional the sense code to ILLEGAL FIELD IN CDB.

Buffer Offset specifies the offset of the memory space specified by the Buffer ID. The initiator should conform to the offset boundary requirements returned in the READ BUFFER descriptor. If the value exceeds the buffer specified, the command is terminated with CHECK CONDITION status. The drive shall set the sense key to ILLEGAL REQUEST and additional sense code to ILLEGAL FIELD IN CDB.

Parameter List Length specifies the Parameter List Length. It must be

- less than the capacity of the buffer size and
- on a sector boundary.

If an invalid value is specified, the command is terminated with CHECK CONDITION status. The drive shall set the sense key to ILLEGAL REQUEST and additional sense code to ILLEGAL FIELD IN CDB.

8.42.3 Download Microcode (Mode 0100b)

In this mode, the microcode is transferred to the control memory space of the drive. When downloaded, the drive will operate with the newly downloaded code immediately until the next power cycle.

Buffer ID field is used to indicate which portion of the microcode image is being downloaded. The following Buffer IDs are supported by the Target:

- 00h : Main Microprocessor Code
- 81h : Reserved Area Data

Any other value for the Buffer ID will cause the command to terminate with CHECK CONDITION status. The drive shall set the sense key to ILLEGAL REQUEST and additional sense code to ILLEGAL FIELD IN CDB.

Buffer Offset must be zero. If an invalid value is specified, the command is terminated with CHECK CONDITION status. The drive shall set the sense key to ILLEGAL REQUEST and additional sense code to ILLEGAL FIELD IN CDB.

Parameter List Length must be the size of the data set to be downloaded. It may also be set to 0000h in which case no code is updated. If an invalid value is specified, the command is terminated with CHECK CONDITION status. The drive shall set the sense key to ILLEGAL REQUEST and additional sense code to ILLEGAL FIELD IN CDB.

This process generates a unit attention condition for MICROCODE HAS BEEN CHANGED for all initiators except the one which sent the write buffer command. Upon the completion of the write buffer command the new microcode is immediately ready for operation.

Note: The Download Microcode mode described in this specification is to indicate that the drive will accept a command with this mode, though it is not expected that a user will ever issue such a command. To use the write buffer command with this mode, a special microcode version is required from development. If such a microcode is released from development, then it will include appropriate instructions on the function of new microcode and its effect on the drive operations after download.

Note: If the write buffer command with this mode is executed and the invalid code is downloaded, then it is to be expected that the drive will never be complete or hang up the subsequent command. This condition is normally recoverable by a power on/off cycle, but there is no guarantee of it.

8.42.4 Download Microcode and Save (Mode 0101b)

In this mode the data is transferred to the drive to save into the System reserved area on the disk. This is for functional upgrade and configuration change reflecting the user's requirements and/or the manufacturer's reason, and it is stored in the media as a permanent copy. The newly downloaded code becomes effective after the drive issues and completes a self-initiated Power On Reset.

Note: It requires up to 30 seconds to update the microcode including the Flash ROM update.

Note: New code to be downloaded to the drive will be provided by development either by request of a customer for an additional function or as a result of a functional change by development. However please note that not all possible fixes or new functions can be applied to a drive in this manner and that there is a very high dependency on the level of ROM code contained within the drive. If an invalid code or a code not compatible with the ROM code is downloaded, the drive will usually reject this code and will continue normal operation. However there is a small possibility that an invalid code will be accepted. If this occurs, the unit usually becomes inoperable and will have to be returned to the manufacturer for recovery.

Buffer ID field is used to indicate which portion of the microcode image is being downloaded. The following Buffer IDs are supported by the Target:

- 00h : Main Microprocessor Code with all others in one (Single Binary or Chunked)
- 01h - 02h : Reserved
- 80h - 82h : Reserved

Any other value for the Buffer ID will cause the command to terminate with CHECK CONDITION status. The drive shall set the sense key to ILLEGAL REQUEST and additional sense code to ILLEGAL FIELD IN CDB.

8.42.4.1 Download Microprocessor Microcode and Save (Buffer ID = 00h)

Two types of download function are supported: Single Binary Download and Single Binary Chunked.

Buffer ID is 00h. (Single Binary Download)

The first one is that the data set consist of all necessary code and tables in a one big data set. This is starting with the special header data followed by tables, RAM code, three Overlay codes, EEPROM data, and Flash-ROM code. (Flash-ROM code is optional depends on the card type and version if card has update capability.) This download function is available when the drive is running with full function (normal running) before this write buffer is issued.

It requires up to 30 seconds to finish the command. After completion of this type of write buffer command the drive will start as "Power on Reset" and running with newly downloaded code and configuration. Therefore the initiator may need special treatment for this target.

Buffer ID is 00h. (Single Binary Chunked)

The second uses the same data set as the first (Single Binary). It separates one big binary file into segments of 32K bytes and then issues a Write buffer command with ID=00 repeatedly with the same number as the segment. The last segment may be equal to or less than 32K bytes. (For example, if the single binary drive size is 288K bytes, there are nine files of 32K bytes. Thus nine continuous Write Buffer commands with ID=00 should be issued.) After issuing continuous Write Buffer for all segments, the drive behavior is the same as the single binary.

8.42.5 Write Data to Echo Buffer (Mode 1010b)

In this mode the target transfers data into the echo buffer. The echo buffer is assigned in the same manner by the target as it would for a write operation. Data will be sent aligned on four-byte boundaries.

Upon successful completion of a Write Buffer command the data will be preserved in the echo buffer unless there is an intervening command to any logical unit in which case it may be changed.

8.43 WRITE EXTENDED (2A)

Byte	Bit							
	7	6	5	4	3	2	1	0
0	Command Code = 2Ah							
1	Reserved = 0		DPO	FUA	Reserved = 0		RelAdr = 0	
2	(MSB) Logical Block Address (LSB)							
3								
4								
5								
6	Reserved = 0							
7	(MSB) Transfer Length (LSB)							
8								
9	VU = 0		Reserved = 0			FLAG	LINK	

Figure 162. WRITE EXTENDED (2A)

The WRITE EXTENDED command requests that the drive write the data transferred from the initiator. This command is processed like the standard WRITE command except for the longer transfer length.

- Transfer length** The number of contiguous blocks to be transferred. If the transfer length is zero, the seek occurs, but no data is transferred. This condition is not considered an error.
- DPO** A DPO (Disable Page Out) bit of one indicates that the data accessed by this command is to be assigned the lowest priority for being written into or retained by the cache. A DPO bit of one overrides any retention priority specified in the Mode Select Page 8 Caching Parameters. A DPO bit of zero indicates that the priority is determined by the retention priority. The Initiator should set the DPO bit when the blocks written by this command are not likely to be read in the near future.
- FUA** Force unit access. A FUA bit of one indicates that the Target must write the data to the media before returning Good Status. A FUA bit of zero indicates that the Target may return Good Status prior to writing the data to the media.
- RelAdr** Relative Block Address is not supported. Must be set to zero.

8.44 WRITE LONG (3F)

Byte	Bit							
	7	6	5	4	3	2	1	0
0	Command Code = 3Fh							
1	Reserved = 0			Reserved = 0			RelAdr = 0	
2 3 4 5	(MSB) Logical Block Address (LSB)							
6	Reserved = 0							
7 8	(MSB) Byte Transfer Length (LSB)							
9	VU = 0		Reserved = 0			FLAG	LINK	

Figure 163. WRITE LONG (3F)

The WRITE LONG command requests the drive to write **one block** of data transferred from the initiator. The transfer data must include

- User Data
- 40 bytes of ECC data

Parameters are

- **Logical Block Address** field specifies the logical block at which the write operation shall occur.
- **Byte Transfer Length.** This field must specify the exact number of bytes of data available for transfer. If a non-zero byte transfer length does not match the available data length, the target terminates the command with CHECK CONDITION status, then the sense key is set to ILLEGAL REQUEST, and an additional sense code is set to INVALID FIELD IN CDB. The valid and ILI bits are set to one and the information field is set to the difference of the requested length minus the actual length in bytes. Negative values are indicated by two's complement notation.
- **RelAdr** (Relative Block Address) is not supported. Must be set to ZERO.

8.45 WRITE SAME (41)

Byte	Bit							
	7	6	5	4	3	2	1	0
0	Command Code = 41h							
1	Reserved = 0			Reserved = 0			RelAdr = 0	
2 3 4 5	(MSB) Logical Block Address (LSB)							
6	Reserved = 0							
7 8	(MSB) Number of Blocks (LSB)							
9	VU = 0		Reserved = 0			FLAG	LINK	

Figure 164. WRITE SAME (41)

The Write Same command instructs the Target to write a single block of data transferred to the Target from the Initiator to a number of sequential logical blocks. This command is useful for writing large data areas without sending all of the data over the SCSI bus.

- **Logical Block Address** specifies the address at which the write begins. The Number of Blocks specifies the number of contiguous blocks to be written. If the number is zero, all of the remaining blocks on the specified Logical Unit are written.
- **RelAdr (Relative Block Address)** is not supported and must be set to be ZERO.

The data for this command is not retained in the cache.

9.0 SCSI Status Byte

Upon the completion of a command a status byte is sent to the initiator. Additional sense information may also be available depending on the contents of the status byte. The following section describes the possible values for the status byte and sense data. All Reserved fields (R) are set to zero.

Bit							
7	6	5	4	3	2	1	0
Reserved = 0		Status Code					RSVD

Figure 165. SCSI Status Byte. Format of the SCSI STATUS byte.

STATUS BYTE	Description
00h	GOOD The command has been successfully completed.
02h	CHECK CONDITION An error, exception, or abnormal condition has been detected. The sense data is set by the drive. The REQUEST SENSE command should be issued to determine the nature of the condition.
08h	BUSY This condition is returned when disconnect privilege is not granted while the drive is BUSY processing the other command for the other initiator. The normal initiator recovery action is to issue the command at a later time or to reissue the command and grant the disconnect privilege.
10h	INTERMEDIATE/GOOD This status is returned for every command in a series of linked commands (except the last command), unless an error, exception, or abnormal condition causes a CHECK CONDITION status or a RESERVATION CONFLICT status to be set. If this status is not returned, the chain of linked commands is broken and no further commands in the series are executed.
18h	RESERVATION CONFLICT This status is returned whenever an SCSI device attempts to access the drive, but it has been reserved by another initiator. (See RESERVE (16) on page 164.)
28h	QUEUE FULL This status indicates that the target's command queue is full. If a tagged command queuing feature is enabled and there is no room on the command queue, this status is returned when the initiator sends a command. For this status sense is not valid.

10.0 SCSI Message System

This chapter details how the message system is implemented on the drive. Included is a functional description of the supported messages.

10.1 Supported Messages

The messages supported by the drive are listed in the figure below.

MESSAGE	CODE(hex)	Direction		Negate ATN Before last ACK
COMMAND COMPLETE	00	IN		---
SYNCHRONOUS DATA TRANSFER REQUEST	010301	IN	OUT	Yes
WIDE DATA TRANSFER REQUEST*	010203	IN	OUT	Yes
PARALLEL PROTOCOL REQUEST	010604	IN	OUT	Yes
SAVE DATA POINTER	02	IN		---
RESTORE POINTERS	03	IN		---
DISCONNECT	04	IN		---
INITIATOR DETECTED ERROR	05		OUT	Yes
ABORT	06		OUT	Yes
MESSAGE REJECT	07	IN	OUT	Yes
NO OPERATION	08		OUT	Yes
MESSAGE PARITY ERROR	09		OUT	Yes
LINKED COMMAND COMPLETE	0A	IN		---
LINKED COMMAND COMPLETE (w/FLAG)	0B	IN		---
BUS DEVICE RESET	0C		OUT	Yes
ABORT TAG	0D		OUT	Yes
CLEAR QUEUE TAG	0E		OUT	Yes
SIMPLE QUEUE TAG	20XX	IN	OUT	No
HEAD OF QUEUE TAG	21XX		OUT	No
ORDERED QUEUE TAG	22XX		OUT	No
IGNORE WIDE RESIDUE*	2301	IN		---
IDENTIFY	80-FF		IN	---
IDENTIFY	80-FF		OUT	No

Key: IN = Target to Initiator, OUT = Initiator to target
YES = Initiator shall negate ATN before last ACK of message
NO = Initiator may or may not negate ATN before last ACK of message
--- = Not applicable
XX = Queue Tag
* = Wide SCSI Only

Figure 166. Supported Messages

If an unsupported message is received, the drive will send the MESSAGE REJECT message to the initiator. If at the time the unsupported message is received a valid NEXUS exists, the drive will continue with the command. If no valid NEXUS exists, the drive will go to Bus Free.

10.1.1 COMMAND COMPLETE (00)

The drive sends this message to the initiator to indicate that the execution of a command has been terminated and that valid status has been sent to the initiator. After successfully sending this message the drive releases all bus signals and goes to BUS FREE phase.

10.1.2 SYNCHRONOUS DATA TRANSFER REQUEST (01,03,01H)

<u>Byte</u>	<u>Value</u>	<u>Description</u>
0	01H	Extended message
1	03H	Extended message length
2	01H	SYNCHRONOUS DATA TRANSFER REQUEST code
3	M	Transfer period (M times 4 nanoseconds)
4	X	REQ/ACK offset

Figure 167. Synchronous Data Transfer Request.

A pair of Synchronous Data Transfer Request (SDTR) messages shown in Figure 159 are exchanged between an Initiator and a Target to establish the synchronous data transfer mode between the two devices. The message exchange establishes the permissible transfer period and REQ/ACK offset for a synchronous data transfer between the two devices. The initiator may initiate a synchronous data transfer negotiation at any time after the LUN has been identified. A Synchronous Data Transfer Request (SDTR) message exchange shall be initiated by a SCSI device whenever a previously arranged data transfer agreement may have become invalid. *The agreement becomes invalid after any condition which may leave the data transfer agreement in an indeterminate state such as*

1. after a Power-on Reset
2. after a SCSI Bus "hard" reset condition
3. after a Bus Device Reset message

In addition a SCSI device may initiate a SDTR message exchange whenever it is appropriate to negotiate a new data transfer agreement (either synchronous or asynchronous).

M The transfer period (M above) is the minimum time allowed between leading edges of successive REQ pulses and of successive ACK pulses to meet the device requirements for successful reception of data. The drive supports transfer period in the range 50 nSec to 425 nSec in increments of 25 nSec. In addition to this , when the drive is working in LVD mode, it supports 25 nSec transfer period.

REQ/ACK Offset

X The ACK/REQ offset (X above) is the maximum number of REQ pulses allowed to be outstanding before the leading edge of its corresponding ACK pulses is received at the drive. A REQ/ACK offset value of zero indicates asynchronous data transfer mode. The drive supports REQ/ACK offset values in the range 0 through 63.

If ATN is negated before all bytes of a multiple-byte extended message is received, the drive will go to **BUS FREE** to signal a catastrophic error.

10.1.2.1 Synchronous Negotiation started by the Initiator

When target respond with REQ/ACK offset value of 0, the initiator shall use asynchronous data transfer mode.

LVD mode. The Target responds to each Initiator requested transfer period as shown below .

Initiator Request	Target Response	Target Transfer Period	Maximum Burst Rate
0 <= Mi <= 09	Mt = 10	(Asynch mode)	N/A
10 <= Mi <= 10	Mt = 10	25 nSec	40.00 MT/s
11 <= Mi <= 12	Mt = 12	50 nSec	20.00 MT/s
13 <= Mi <= 18	Mt = Mi	75 nSec	13.33 MT/s
19 <= Mi <= 25	Mt = Mi	100 nSec	10.00 MT/s
26 <= Mi <= 31	Mt = Mi	125 nSec	8.00 MT/s
32 <= Mi <= 37	Mt = Mi	150 nSec	6.67 MT/s
38 <= Mi <= 43	Mt = Mi	175 nSec	5.71 MT/s
44 <= Mi <= 50	Mt = Mi	200 nSec	5.00 MT/s
51 <= Mi <= 56	Mt = Mi	225 nSec	4.44 MT/s
57 <= Mi <= 62	Mt = Mi	250 nSec	4.00 MT/s
63 <= Mi <= 68	Mt = Mi	275 nSec	3.64 MT/s
69 <= Mi <= 75	Mt = Mi	300 nSec	3.33 MT/s
76 <= Mi <= 81	Mt = Mi	325 nSec	3.08 MT/s
82 <= Mi <= 87	Mt = Mi	350 nSec	2.86 MT/s
88 <= Mi <= 93	Mt = Mi	375 nSec	2.67 MT/s
94 <= Mi <= 100	Mt = Mi	400 nSec	2.50 MT/s
101 <= Mi <= 106	Mt = Mi	425 nSec	2.35 MT/s
107 <= Mi <= 255	Mt = 106	(Asynch mode)	N/A

Figure 168. Initiator Request/Target Response (LVD mode)

SE mode. The Target responds to each Initiator requested transfer period as shown below.

Initiator Request	Target Response	Target Transfer Period	Maximum Burst Rate
0 <= Mi <= 11	Mt = 12	(Asynch mode)	N/A
12 <= Mi <= 12	Mt = 12	50 nSec	20.00 MT/s
13 <= Mi <= 18	Mt = Mi	75 nSec	13.33 MT/s
19 <= Mi <= 25	Mt = Mi	100 nSec	10.00 MT/s
26 <= Mi <= 31	Mt = Mi	125 nSec	8.00 MT/s
32 <= Mi <= 37	Mt = Mi	150 nSec	6.67 MT/s
38 <= Mi <= 43	Mt = Mi	175 nSec	5.71 MT/s
44 <= Mi <= 50	Mt = Mi	200 nSec	5.00 MT/s
51 <= Mi <= 56	Mt = Mi	225 nSec	4.44 MT/s
57 <= Mi <= 62	Mt = Mi	250 nSec	4.00 MT/s
63 <= Mi <= 68	Mt = Mi	275 nSec	3.64 MT/s
69 <= Mi <= 75	Mt = Mi	300 nSec	3.33 MT/s
76 <= Mi <= 81	Mt = Mi	325 nSec	3.08 MT/s
82 <= Mi <= 87	Mt = Mi	350 nSec	2.86 MT/s
88 <= Mi <= 93	Mt = Mi	375 nSec	2.67 MT/s
94 <= Mi <= 100	Mt = Mi	400 nSec	2.50 MT/s
101 <= Mi <= 106	Mt = Mi	425 nSec	2.35 MT/s
107 <= Mi <= 255	Mt = 106	(Asynch mode)	N/A

Figure 169. Initiator Request/Target Response (SE mode)

10.1.2.2 Synchronous Negotiation started by the Target

If the drive recognizes that negotiation is required, the drive sends a SDR message to the initiator with minimum transfer period on the current receiver mode. The drive interprets the Initiator corresponding transfer period as shown in the figure below.

LVD mode.

Initiator's Request	Target Transfer Period	Maximum Burst Rate
0 <= Mi <= 09	Send Message Reject (Asynch mode)	N/A
10 <= Mi <= 10	25 nSec	40.00 MT/s
11 <= Mi <= 11	50 nSec	20.00 MT/s
12 <= Mi <= 12	50 nSec	20.00 MT/s
13 <= Mi <= 18	75 nSec	13.33 MT/s
19 <= Mi <= 25	100 nSec	10.00 MT/s
26 <= Mi <= 31	125 nSec	8.00 MT/s
32 <= Mi <= 37	150 nSec	6.67 MT/s
38 <= Mi <= 43	175 nSec	5.71 MT/s
44 <= Mi <= 50	200 nSec	5.00 MT/s
51 <= Mi <= 56	225 nSec	4.44 MT/s
57 <= Mi <= 62	250 nSec	4.00 MT/s
63 <= Mi <= 68	275 nSec	3.64 MT/s
69 <= Mi <= 75	300 nSec	3.33 MT/s
76 <= Mi <= 81	325 nSec	3.08 MT/s
82 <= Mi <= 87	350 nSec	2.86 MT/s
88 <= Mi <= 93	375 nSec	2.67 MT/s
94 <= Mi <= 100	400 nSec	2.50 MT/s
101 <= Mi <= 106	425 nSec	2.35 MT/s
107 <= Mi <= 255	Send Message Reject (Asynch mode)	N/A

Figure 170. Target Response to Initiator's Transfer Period (LVD mode)

SE Mode.

Initiator's Request	Target Transfer Period	Maximum Burst Rate
0 <= Mi <= 11	Send Message Reject (Asynch mode)	N/A
12 <= Mi <= 12	50 nSec	20.00 MT/s
13 <= Mi <= 18	75 nSec	13.33 MT/s
19 <= Mi <= 25	100 nSec	10.00 MT/s
26 <= Mi <= 31	125 nSec	8.00 MT/s
32 <= Mi <= 37	150 nSec	6.67 MT/s
38 <= Mi <= 43	175 nSec	5.71 MT/s
44 <= Mi <= 50	200 nSec	5.00 MT/s
51 <= Mi <= 56	225 nSec	4.44 MT/s
57 <= Mi <= 62	250 nSec	4.00 MT/s
63 <= Mi <= 68	275 nSec	3.64 MT/s
69 <= Mi <= 75	300 nSec	3.33 MT/s
76 <= Mi <= 81	325 nSec	3.08 MT/s
82 <= Mi <= 87	350 nSec	2.86 MT/s
88 <= Mi <= 93	375 nSec	2.67 MT/s
94 <= Mi <= 100	400 nSec	2.50 MT/s
101 <= Mi <= 106	425 nSec	2.35 MT/s
107 <= Mi <= 255	Send Message Reject (Asynch mode)	N/A

Figure 171. Target Response to Initiator's Transfer Period (SE mode)

10.1.3 WIDE DATA TRANSFER REQUEST (01,02,03H)

A pair of Wide Data Transfer Request messages is exchanged between an Initiator and a Target to establish a data transfer width agreement between the two devices. The Initiator may initiate a wide data transfer negotiation at any time after the LUN has been identified. The Target initiates a wide data transfer negotiation if the Target has not negotiated with the Initiator since the last time the Target was Reset (Power-on Reset, SCSI Bus Hard Reset, or Bus Device Reset message).

Target-initiated negotiation occurs either immediately following the Command phase or immediately following the first reconnection. In either case negotiation occurs before any Data phase between the Target and the Initiator. The Target will negotiate the data transfer width agreement prior to negotiating the synchronous data transfer agreement. If a synchronous data transfer agreement is in effect when a Wide Data Transfer Request message is received, the Target will reset the synchronous agreement to asynchronous mode.

The implied data transfer width agreement remains in effect until the Target is Reset (Power-on Reset, SCSI Bus "hard" Reset, or Bus Device Reset message) or a new data transfer width agreement is negotiated. If a Reset occurs, the Target goes to eight bit mode.

Byte	Value	Description
0	01H	Extended message
1	02H	Extended message length
2	03H	WIDE DATA TRANSFER REQUEST code
3	E	Transfer width exponent

Figure 172. Wide Data Transfer Request.

- E** The Transfer Width Exponent (E) is two to the transfer width exponent bytes wide. Valid data transfer widths are 8 bits (E = 00h) and 16 bits (E = 01h). Value of E greater than 01h are reserved.

10.1.3.1 Transfer Width Negotiation started by the Initiator

If the Initiator recognizes that negotiation is required and sends a Wide Data Transfer Request message out, the Target responds by changing to the Message In phase and sending a Wide Data Transfer Request message in to the Initiator prior to transferring any additional message bytes (or any other Information phase bytes) from the Initiator. This provides an interlock during the data transfer width negotiation.

The drive responds to each Initiator requested transfer width exponent as shown in the following table.

Initiator Request	Target Response	Target Data Transfer Width
E _i = 00h	E _t = 00h	8 Bit Data Transfers
E _i > 00h	E _t = 01h	16 Bit Data Transfers

Figure 173. Initiator Request/Target Response

If after the Target's response above the Initiator asserts the ATN signal and the first message received is either a Message Parity Error or a Message Reject message, the Target negates the data transfer width agreement and goes to 8 bits mode. For the Message Parity Error case the implied data transfer width agreement is reinstated if the Target successfully retransmits the Wide Data Transfer Request message to the Initiator. For any other message the Target completes negotiation and goes to the negotiated data transfer width.

10.1.3.2 Transfer Width Negotiation started by the Target

If the Target recognizes that negotiation is required, the Target sends a Wide Data Transfer Request message to the Initiator with the transfer width exponent equal to 1 (E = 01h). The Initiator must respond by asserting the ATN signal prior to its release of ACK for the REQ/ACK handshake of the last byte of the Wide Data Transfer Request message. This provides an interlock during the wide data transfer negotiation. If the Initiator does not assert the ATN signal, the Target goes to 8 bit mode. If the Initiator does assert the ATN signal, the Target changes to the Message Out phase and receives a message from the Initiator.

If the first message received is a Wide Data Transfer Request message, the Target establishes the new data transfer mode. The drive interprets the Initiator corresponding transfer width exponent as shown in the following table.

Initiator Request	Target Data Transfer Width
E _i = 00h	8 Bit Data Transfers
E _i = 01h	16 Bit Data Transfers
E _i > 01h	Send Message Reject (8 Bit Data Transfer)

Figure 174. Target Request to Initiator

Note: If the corresponding transfer width exponent received from the Initiator indicates a data transfer width that is greater than 16 bits (E > 01h), the Target sends a Message Reject message to the initiator to indicate 8 bit data transfer mode.

If the first message received from the Initiator is either a Message Parity Error or a Message Reject message, the Target goes to 8 bit data transfer mode. In the case of a Message Parity Error, the wide data transfer negotiation is restarted if the Target successfully retransmits the Wide Data Transfer Request message to the Initiator.

If the first message received from the Initiator is any other message, the Target goes to 8 bit data transfer mode. The Target assumes that the Initiator does not support wide data transfer and does not attempt to renegotiate with this Initiator.

The implied agreement for wide data transfer operation is not considered to exist by the Target until the Target leaves the Message Out phase, implying that no parity error was detected. If the Target detects a parity error while attempting to receive the message from the Initiator, the Target goes to 8 bit data transfer mode. The Target will attempt to resume the wide data transfer negotiation by retrying the Message Out phase.

Note: If during the Message In phase of negotiations, either Target or Initiator started, ATN is asserted prior to transmission of the last byte of the message and the message is not Message Parity or Message Reject, the Target goes to 8 bit data transfer mode.

10.1.4 PARALLEL PROTOCOL REQUEST (01,06,04H)

Parallel Protocol Request messages are used to negotiate a synchronous data transfer agreement and a wide data transfer agreement and to set the protocol options between two SCSI devices.

Byte	Value	Description
0	01h	Extended message
1	06h	Extended message length
2	04h	Parallel Protocol Request
3	09h	Transfer period factor (80M/T)
4	00h	Reserved
5	X	REQ/ACK Offset
6	m	Transfer Width Exponent
7	02h	Protocol Option (DT_REQ Only)

Figure 175. Parallel Protocol Request.

REQ/ACK Offset

X The REQ/ACK Offset value is chosen to prevent overflow conditions in the reception buffer of the device and offset counter and the Target supports maximum offset of 63 (3Fh). A REQ/ACK Offset value of zero indicates asynchronous data transfer mode and that the Period Factor field and the Protocol Option field will be ignored.

M The Transfer Wide Exponent field defines the transfer width to be used during DATA IN phases and DATA OUT phases. The transfer width that is established applies to all logical units on both SCSI devices. Valid transfer widths are 8 bits (m=00h) and 16 bits (m=01h) if all the protocol options bits are zero. The only valid transfer width is 16 bits (m=01h) if any of the protocol options bits are one.

The protocol options bits (IU_REQ, DT_REQ, and QAS_REQ) are used by the originating SCSI device to indicate the protocol options to be enabled.

Bit							
7	6	5	4	3	2	1	0
Reserved					QAS_R	DT_RE	IU_RE

Figure 176. Bit position table for Byte 7 of Parallel Protocol Request

QAS_REQ (Quick Arbitrate and Select) is not supported. The bit should be zero.

DT_REQ A bit of zero for DT_REQ (Double Transition Enable Request) indicates that DT DATA phases are to be disabled when received from the originating SCSI device and that DT DATA phases are not supported when received from the responding SCSI device.

A DT_REQ bit of one indicates that DT DATA phases are to be enabled when received from the originating SCSI device and that DT DATA phases are supported when received from the responding SCSI device.

IU_REQ (Information Unit Request) is not supported. The bit should be 0.

10.1.5 SAVE DATA POINTER (02)

This message is sent from the drive to direct the initiator to copy the active data pointer to the saved data pointer. The SAVE DATA POINTER message is only sent if the initiator has previously indicated the ability to accommodate disconnection and reconnection via the IDENTIFY message.

The drive will send the SAVE DATA POINTER message to the initiator prior to sending a DISCONNECT message to the initiator if a data phase has occurred and another data phase is required to successfully complete the command.

10.1.6 RESTORE POINTERS (03)

This message is sent from the drive to direct an initiator to copy the most recently saved pointers to the corresponding command, data, and status pointers. Command and status pointers should be restored to the beginning of the present command and status areas. The data pointer should be restored to the value at the beginning of the data area in the absence of a SAVE DATA POINTER message or to the value at the point at which the last SAVE DATA POINTER message occurred. Also see **SCSI Bus Related Error Handling Protocol** on page 207.

10.1.7 DISCONNECT (04)

This message is sent from the drive to inform an initiator that the present connection is going to be broken. A later reconnect will be required in order to complete the current command. The disconnection serves to free the SCSI bus while the drive performs a relatively long operation that does not require the bus. These messages are sent only if the initiator previously indicated (via the IDENTIFY message) the ability to accommodate disconnection and reconnection.

The DISCONNECT message may also be sent from the initiator to the drive to disconnect from the SCSI bus. The drive does not support the DISCONNECT message from the initiator. And it always responds by sending MESSAGE REJECT message to the initiator.

10.1.8 INITIATOR DETECTED ERROR (05)

This message is sent from an initiator to inform the drive that an error has been detected that does not preclude the drive from retrying the previous COMMAND, DATA and STATUS phase. The source of the error may be either related to previous activities on the SCSI bus or may be internal to the initiator and unrelated to any previous SCSI bus activity

If the initiator intends to send this message, the initiator must assert the ATN signal prior to its release of ACK for the last byte transferred in the information phase that is to be retried. This provides an interlock so the drive can determine which information phase to retry.

After receiving this message the drive may retry the previous phase by sending a RESTORE POINTERS message to the initiator and then repeating the previous COMMAND, DATA, or STATUS phase.

10.1.9 ABORT (06)

This message is sent from the initiator to direct the drive to clear the present operation for this initiator and logical unit including queued command(s). If a logical unit has been identified, then all pending data and status for the issuing initiator and this logical unit will be cleared and the drive will go to the BUS FREE phase. Pending data and status for other logical unit and initiators will not be cleared. If a logical unit has not been identified, the drive will go to the BUS FREE phase without affecting an operation on any logical unit for this initiator or any other initiator. In either case no status or ending message will be sent to the initiator for this operation. It is not an error to send the ABORT message to a logical unit that is not currently performing an operation for the initiator.

Note: It is permissible for an initiator to select the drive/LUN after the drive has disconnected from the initiator for the purpose of sending an IDENTIFY message followed by an ABORT message. This will abort the command on the specified logical unit.

10.1.10 MESSAGE REJECT (07)

This message is sent from either the initiator or the drive to indicate that the last message received was inappropriate or has not been implemented.

If the initiator intends to send this message, the initiator must assert the ATN signal prior to its release of ACK for the REQ/ACK handshake of the message byte that is to be rejected. This provides an interlock so the drive can determine which message is rejected.

If the drive intends to send this message, the drive will change to the MESSAGE IN phase and send the MESSAGE REJECT message to the initiator prior to transferring any additional message bytes (or any other information phase bytes) from the initiator regardless of ATN signal. This provides an interlock so the initiator can determine which message is rejected. After the drive sends a MESSAGE REJECT message and if ATN signal is still asserted, it shall return to the MESSAGE OUT phase. The subsequent MESSAGE OUT phase shall begin with the first byte of a message.

10.1.11 NO OPERATION (08)

This message is sent from the initiator to the drive when the initiator does not currently have any other valid message to send. This message is ignored by the drive and will not affect any operation.

10.1.12 MESSAGE PARITY ERROR (09)

This message is sent from the initiator to inform the drive that the last message byte received had a parity error.

If the initiator intends to send this message, the initiator must assert the ATN signal prior to its release of ACK for the REQ/ACK handshake of the message byte that has the parity error. This provides an interlock so the drive can determine which message byte has the parity error.

If the drive receives this message under any other circumstance, the drive will change to BUS FREE to signal a catastrophic error. After receiving this message, the drive will retry sending the previous message to the initiator.

10.1.13 LINKED COMMAND COMPLETE (0A)

The drive sends this message to the initiator to indicate that execution of a linked command (with flag bit equal to zero) has completed and that valid status has been sent to the initiator. After successfully sending this message, the drive goes to COMMAND phase to receive the next command.

10.1.14 LINKED COMMAND COMPLETE WITH FLAG (0B)

The drive sends this message to the initiator to indicate that the execution of a linked command with flag bit set to one has completed and that valid status has been sent to the initiator. After successfully sending this message, the drive goes to COMMAND phase to receive the next command.

10.1.15 BUS DEVICE RESET (0C)

This message is sent from an initiator to direct the drive to clear all current commands. This message forces a hard reset condition which will reset the drive to an initial state with no operations pending for any initiator. After receiving this message the drive will go to the BUS FREE phase.

10.1.16 ABORT TAG (0D)

When the target successfully receives this message, it clears the current I/O process and go to Bus Free. If the target has already started execution of an I/O process, the execution will be halted. Pending status, data, and commands for other active or queued I/O processes shall not be affected.

10.1.17 CLEAR QUEUE TAG (0E)

All I/O processes for all initiators shall be cleared. All active I/O processes shall be terminated. The target shall go to the Bus Free phase following successfully receipt of this message.

10.1.18 QUEUE TAG MESSAGES (20h, 21h, 22h)

Byte	Value	Description
0	20H	Simple Queue Tag message
	21H	Head of Queue Tag message
	22H	Ordered Queue Tag message
1	XXh	Queue Tag

Figure 177. Queue Tag Messages

Queue Tag messages are used to specify an identifier called a Queue Tag for an I/O process which establish the I_T_L_Q nexus. The queue tag field is an 8-bit unsigned integer assigned by the initiator during an initial connection. The Queue Tag for every I/O process for each I_T_L nexus must be unique. If the target receives a Queue Tag that is currently in use for the I_T_L nexus, it will respond as "Incorrect Initiator Response". A Queue Tag becomes available for reassignment when I/O process ends. The numeric value of a Queue Tag has no effect on the order of execution.

Whenever an initiator connects to the target, the appropriate Queue Tag message must be sent immediately following the Identify message and within the same MESSAGE OUT phase to establish the I_T_L_Q nexus for the I/O process.

Whenever the target reconnects to an initiator to continue a tagged I/O process, the Simple Queue Tag message is sent immediately following the Identify and within the same MESSAGE IN phase to revive the I_T_L_Q nexus for the I/O process.

10.1.18.1 SIMPLE QUEUE TAG (20h)

The Simple Queue Tag Message specifies that the current I/O process be placed in the command queue. The order of execution with respect to other I/O processes received with Simple Queue Tag Messages is up to the discretion of the target. The target will send a Simple Queue Tag Messages after reselection for I/O processes that were received with either Simple, Ordered, or Head of Queue Tag messages.

10.1.18.2 HEAD OF QUEUE TAG (21h)

Commands with this tag should be inserted into the head of the queue. When a command is being executed, this tagged command will be inserted to the head of queue to be executed after the command being currently executed. The previous executed command will not be terminated by this tagged command. This tagged command will wait until the previous command is completed. If plural head-of-queue tagged commands are received, those command will be executed in LIFO (Last in First out) order.

10.1.18.3 ORDERED QUEUE TAG (22h)

This tagged command is executed in the order received. All commands received before this command should be executed before this command and all commands received after this commands should be executed after this command.

10.1.19 IGNORE WIDE RESIDUE (23h)

Byte	Value	Description
0	23H	Ignore Wide Residue message
1	01H	Ignore

Figure 178. Ignore Wide Residue Message Format

The Ignore Wide Residue Message is sent from the target to indicate that the number of valid bytes sent during the last REQ/ACK handshake of a DATA IN phase is less than the negotiated transfer width. The ignore field (always = 01h) indicates that one byte (data bits 8-15) should be ignored. This message is sent immediately after the DATA IN phase and prior to any other messages. Even though a byte is invalid, its corresponding parity bit is valid for the value transferred.

10.1.20 IDENTIFY (80 - FF)

This message is set by either the initiator or the drive to establish the logical path connection between the two devices.

The IDENTIFY message is defined as follows:

- Bit 7** This bit is always set to one to distinguish the IDENTIFY message from other messages.
- Bit 6** This bit is only set to one by the initiator to grant the drive the privilege of disconnecting. If this bit is zero, the drive will not disconnect unless the initiator instructs the drive to disconnect by sending a DISCONNECT Message to the drive. This bit is set to zero when the drive sends an IDENTIFY message to the initiator.
- Bits 5-0** These bits specify the logical unit number (LUN).
Only one LUN may be identified for any one selection sequence. If the drive receives an IDENTIFY message with a new LUN after the LUN had previously been identified, the drive will go to the BUS FREE phase to signal a catastrophic error. The initiator may send more than one Identify message during a selection sequence in order to toggle disconnect/reconnect permission if the specified LUN remains the same.

When the IDENTIFY message is sent from the drive to the initiator during reconnection, an implied RESTORE POINTERS message must be performed by the initiator.

10.2 Supported Message Functions

The implementation of the supported messages will also include the following functions.

- Retry SCSI Command or STATUS phase

The retry will be caused by the following error condition.

- The drive detected SCSI bus parity error (Command phase)
- The drive receives INITIATOR DETECTED ERROR MESSAGE during or at the conclusion of an information transfer phase (Command Data Out or Status Phase)

Note: The initiator may send the INITIATOR DETECTED ERROR message as a result of an initiator detected SCSI Bus parity error or an internal error.

- Retry MESSAGE IN phase

The retry will be caused by the receipt of a MESSAGE PARITY ERROR message immediately following a MESSAGE IN phase.

Note: The Initiator may send the MESSAGE PARITY ERROR message as a result of an Initiator detected SCSI Bus parity error during the Message In phase.

- Receipt of multiple Identify message

- The initiator is allowed to send multiple IDENTIFY messages out in order to toggle the disconnect/reconnect permission bit. This may be used to selectively enable or disable disconnect/reconnect permission during portions of a command. Note that this function does not affect the operation of the Forced Disconnect function.

- MESSAGE REJECT during Target Disconnection

- If the Initiator rejects the SAVE DATA POINTER message, the drive will disable disconnect/reconnect permission. This is equivalent to receiving an IDENTIFY message with bit 6 equal to zero. This will cause the drive to inhibit the pending disconnection.
- If the initiator rejects the DISCONNECT message, the drive will not disconnect but may attempt to disconnect at a later time. This function may be used to selectively disable disconnection during portions of a command.

10.3 Attention Condition

The attention condition allows an initiator to inform the drive that a MESSAGE OUT phase is desired. The initiator may create the attention condition by asserting the ATN signal at any time except during the ARBITRATION or BUS FREE phases.

The initiator must create the attention condition by asserting the ATN signal at least two deskew delays before releasing ACK for the last byte transferred in a bus phase to guarantee that the attention condition will be honored before transition to a new bus phase. This will guarantee a predictable drive response to a message received during the MESSAGE OUT phase for this attention condition. If the ATN signal is asserted later, it may be honored in the current bus phase or the next bus phase and then may not result in the expected action.

After the initiator asserts the ATN signal, the drive will respond with the MESSAGE OUT phase as follows:

Current Phase	Response
COMMAND	Message Out phase will occur after part or all of the Command Descriptor Block has been transferred to the drive. The initiator must continue REQ/ACK handshakes during the Command phase until the drive enters the MESSAGE OUT phase.
DATA	The MESSAGE OUT phase will occur after part or all of the data bytes have been transferred and not necessarily on a logical block boundary. The initiator must continue REQ/ACK handshakes (asynchronous transfer) until it detects the phase change. Note: In synchronous transfer the initiator must continue sending ACK pulses to reach an offset of zero.
STATUS	The MESSAGE OUT phase will occur after the REQ/ACK handshake of the status byte has been completed.
MESSAGE IN	The MESSAGE OUT phase will occur before the drive sends another message.
SELECTION	If ATN occurs during a SELECTION phase and before the initiator releases the BSY signal, the MESSAGE OUT phase will occur immediately after that SELECTION phase.
RESELECTION	The MESSAGE OUT phase will occur after the drive has sent its IDENTIFY message for that RESELECTION phase. (First the drive tries to complete the reselection.)

The initiator must keep the ATN signal asserted if more than one message byte is to be transferred during the MESSAGE Out phase. The drive will process each message byte (multiple bytes for an extended message) prior to receiving the next message from the initiator. The drive will continue to handshake and process byte(s) in the MESSAGE OUT phase until ATN goes false unless one of the following conditions occurs:

1. The drive receives an illegal or inappropriate message and goes to the MESSAGE IN phase to send a MESSAGE REJECT message.
2. The drive detects a catastrophic error condition and goes to the BUS FREE phase.

10.4 SCSI Bus Related Error Handling Protocol

This protocol is used to handle errors that threaten the integrity of a connection between the Target and an Initiator.

10.4.1 Unexpected BUS FREE Phase Error Condition

There are several error conditions that will cause the drive to immediately change to the BUS FREE phase regardless of the state of the ATN signal. The drive will not attempt to reconnect to the initiator to complete the operation that was in progress when the error condition was detected. The initiator should interpret this as a catastrophic error condition.

If the LUN was identified by the drive prior to the error condition, the drive will abort the active command for this initiator/LUN and generate sense data for this initiator/LUN to describe the cause of the catastrophic error. The initiator may retrieve this sense data by issuing a REQUEST SENSE command to this LUN. Note however, that the REQUEST SENSE command may fail if the catastrophic error condition persists.

If the LUN was not identified by the drive prior to the error condition, the drive will not affect the sense data or the operation of any currently executing command for this initiator or any other initiator.

10.4.2 MESSAGE OUT Phase Parity Error

Depending on the model⁷ the drive will optionally retry the message phase and, if it still fails, abort the current command with CHECK CONDITION status and sense data of ABORTED COMMAND / SCSI PARITY ERROR.

10.4.3 MESSAGE IN Phase Parity Error (Message Parity Error)

Depending on the model⁸ the drive may retry the message phase and, if it still fails, abort the current command and go to bus free, setting sense data of ABORTED COMMAND / SCSI PARITY ERROR.

10.4.4 COMMAND Phase Parity Error

Depending on the model⁹ the drive may retry the command phase after sending a restore pointers message. If it still fails, it will abort the current command with CHECK CONDITION status and sense data of ABORTED COMMAND / SCSI PARITY ERROR.

10.4.5 DATA OUT Phase Parity Error

If the drive detects a parity error during DATA OUT phase, the drive will abort the current command with CHECK CONDITION status and sense data of ABORTED COMMAND / SCSI PARITY ERROR.

⁷ The action for a particular file model is defined in the optional customized interface spec addendum for each model.

⁸ The action for a particular file model is defined in the optional customized interface spec addendum for each model.

⁹ The action for a particular file model is defined in the optional customized interface spec addendum for each model.

10.4.6 INITIATOR DETECTED ERROR Message

An INITIATOR DETECTED ERROR message is valid after a COMMAND, DATA IN/OUT or STATUS phase has occurred. If another phase has occurred, the message is rejected.

The drive will, depending on the model, optionally retry the previous phase if it is command or status. If this fails or the previous phase was a data transfer the drive will generate a CHECK CONDITION status and a Sense key of ABORTED COMMAND with additional sense code of INITIATOR DETECTED ERROR.

10.4.7 MESSAGE REJECT Message

The drive will take the following actions after receiving the MESSAGE REJECT message in response to messages listed below.

DISCONNECT	The drive is not disconnect but remains connected.
COMMAND COMPLETE	No error, continue to bus free.
IDENTIFY	Command aborted - bus freed - Sense data set to MESSAGE REJECT ERROR.
LINKED CMD CMPLT	Command aborted - link broken - bus freed - sense data set to MESSAGE REJECT ERROR.
MESSAGE REJECT	Command aborted - STATUS phase executed with CHECK CONDITION - sense data set to MESSAGE REJECT ERROR.
RESTORE POINTERS	Command aborted - status set to CHECK CONDITION - sense will be set with the error that caused the RESTORE POINTERS message to be issued. (Assuming that error recovery is in progress)
SAVE DATA POINTER	The drive will not disconnect from the SCSI bus and it will not be considered an error.
No previous Msg	The command is aborted, the bus freed, and Sense data is set to MESSAGE REJECT ERROR. This occurs when the drive has not sent a message, but gets a MESSAGE REJECT from the initiator.

11.0 Additional information

This chapter provides additional information or descriptions of various functions, features, or operating models supported by the Target that are not fully described in previous chapters.

11.1 SCSI Protocol

There are various operating conditions that prevent the Target from executing a SCSI command. This section describes each of these operating conditions and their relative priority.

11.1.1 Priority of SCSI Status Byte Reporting

After establishing the I_T_L nexus or I_T_L_Q nexus the Target must first determine whether command execution is allowed. Execution is deferred until a later time if the command must be added to the command queue. Execution may also be prevented by an internal Target condition that requires the reporting of a Check Condition, Queue Full, Busy or Reservation Conflict Status. There are several different internal conditions to be active at the same time. The order in which the Target checks for each of these conditions determines their priority (highest priority first) as follows:

1. Check Condition status for invalid Logical Unit Number. (see 11.1.2, “Invalid LUN in Identify Message”)
2. Check Condition status for Incorrect Initiator Connection (see 11.1.3, “Incorrect Initiator Connection”)
3. Busy Status or Queue Full Status (see 11.1.4, “Command Processing During Execution of Active I/O process”)
4. Check Condition status for Unit Attention condition (see 11.1.5, “Unit Attention Condition”)
5. Check Condition status during Startup and Format operations (see 11.1.6, “Command Processing During Startup and Format Operations”)
6. Check Condition status for Deferred Error Condition (see 11.1.8, “Deferred Error”)
7. Reservation Conflict status (see 11.1.10, “Command Processing While Reserved”)
8. Check Condition status for invalid command opcode
9. Check Condition status for invalid command descriptor block

The highest priority internal condition that prevents command execution is reported by the Target provided there is no bus error.

For all Check Conditions Sense data is built by the target provided a valid LUN address is known. Sense data is cleared by the Target upon receipt of any subsequent command to the LUN from the initiator receiving the Check Condition.

11.1.2 Invalid LUN in Identify Message

There are three different circumstances defined within the SCSI protocol when the response to an invalid LUN will occur. Each of these result in a different response.

11.1.2 .1 Case 1 - Selection message sequence with Inquiry command

The INQUIRY command is a special case in SCSI. It is used to configure the bus when the drive ID's and LUN's are not known. The proper response is to return the inquiry data with a peripheral drive type of 1Fh which indicates that the specified LUN is not supported.

11.1.2 .2 Case 2 - Selection message sequence with any other command

Any other commands except REQUEST SENSE return CHECK CONDITION status when an invalid LUN is specified in the message sequence following selection. In response to a REQUEST SENSE command the target shall return sense data. The sense key shall be set to ILLEGAL REQUEST and the additional sense code shall be set to LOGICAL UNIT NOT SUPPORTED.

11.1.2 .3 Case 3 - After selection message sequence

It is permissible for the initiator to issue multiple IDENTIFY messages during a single command sequence provided the LUN remains the same. If the LUN is altered, the drive goes to a Bus Free Phase.

11.1.3 Incorrect Initiator Connection

Incorrect Initiator Connection error is reported if any of the following occur:

- an Initiator attempts to establish an I_T_L nexus when an I/O process (either queued or active) with an I_T_L nexus already exists from a previous connection with the same initiator.
- an Initiator attempts to establish an I_T_L_Q nexus when an I_T_L nexus already exists from a previous connection with the same initiator.
- an Initiator attempts to establish an I_T_L nexus when an I_T_L_Q nexus already exists from a previous connection with the same initiator.

Note: It is not an Incorrect Initiator Connection to send a command without a Queue tag message when sense is pending on the logical unit for the Initiator that issues the Request Sense command. (If the command is not Request Sense or Inquiry, sense data is cleared upon receipt of the command.)

- an Initiator attempts to establish an I_T_L_Q nexus when an I/O process (either queued or active) with an I_T_L_Q nexus already exists from a previous connection with the same initiator.

If any of the above errors occur, all queued I/O processes and active I/O processes associated with the issuing Initiator on the specified logical unit are terminated. The current I/O process is ended with a CHECK CONDITION status, the sense key is set to ABORTED COMMAND, and the additional sense code is set to OVERLAPPED COMMANDS ATTEMPTED. Status is only returned for the current I/O process.

11.1.4 Command Processing during execution of active I/O process

When the Target is not executing any active I/O processes, a new I/O process is permitted to execute (unless execution is prevented by another internal Target condition listed in 11.1.1, "Priority of SCSI Status Byte Reporting").

If an active I/O process does exist when the Target receives a new command, then the Target determines if

- Check Condition Status with Sense Key = Aborted Command is returned for an Overlapped Commands Attempted error
- the command is permitted to execute
- the command is added to the command queue
- Queue Full Status is returned
- Busy Status is returned

If an active I/O process does exist when the Target receives a new command, then the Target determines how the new command should be handled based on the following rules:

- Check Condition Status is returned with Sense Key set to Aborted Command for an Overlapped Commands Attempted error if
 - See 11.1.3, "Incorrect Initiator Connection."
- the command is permitted to execute if
 - the command is an Inquiry or Request Sense command
- Check Condition Status is returned with Sense Key set to Logical Unit Not Ready if
 - the startup operation or format operation is an active process.
- the command is permitted to execute if
 - the conditions to execute concurrently are met. (See 11.5, "Concurrent I/O Process.")
- the command is added to the command queue for an I_T_L nexus if
 - no Queue Tag message was received during the connection which established the I/O process, and
 - disconnection is allowed for the current I/O process, and
 - there is no queued I/O process or active I/O process corresponding to the I_T_L nexus for the current I/O process, and
 - the command is not linked to a previous command.
- the command is added to the command queue for an I_T_L_Q nexus if
 - a Queue Tag message was received during the connection which established the I/O process, and
 - Tagged Queuing is enabled (DQue = 0), and
 - an I/O process (either active or queued) exists at the Target for this Initiator, and
 - disconnection is allowed for the current I/O process, and
 - there is no queued I/O process or active I/O process corresponding to the I_T_L_Q nexus for the current I/O process, and
 - the command is not linked to a previous command.

- Queue Full Status is returned if
 - the command would otherwise be queued (according to the rules described above) but the command queue is full and all slots are utilized, or
 - the command would otherwise be queued (according to the rules described above) but all of the available command queue slots not reserved for use by another initiator are utilized, or
 - Tagged Queuing is enabled (DQue = 0) and a Format Unit command was previously queued but has not yet begun execution, or
 - Tagged Queuing is enabled (DQue = 0) and a Start Unit command was previously queued but has not yet begun execution.
- Busy Status is returned if
 - Tagged Queuing is disabled (DQue = 1) and a Format Unit command was previously queued but has not yet begun execution, or
 - Tagged Queuing is disabled (DQue = 1) and a Start Unit command was previously queued but has not yet begun execution, or
 - the command would otherwise be queued (according to the rules described above) but disconnection is not allowed for the current I/O process.

If a command is queued, command execution may still be prevented at a later time when the command is dequeued to become an active I/O process. This occurs if command execution is prevented by another internal Target condition listed in 11.1.1, "Priority of SCSI Status Byte Reporting" at the time the command is dequeued.

11.1.5 Unit Attention Condition

The drive will generate a unit attention condition for each initiator whenever

- The drive has been reset. This includes Power On Reset, SCSI Bus Reset, SCSI BUS DEVICE RESET message.
- The mode parameters in effect for this initiator have been changed by another initiator.
- The microcode has been changed. WRITE BUFFER command has been executed to download microcode. In this case a unit attention condition is generated for all initiators except the one that issued the command.
- Commands are cleared by another initiator. This condition is generated against the initiator that has queued commands if
 - Clear Queue Message is received.
 - Contingent Allegiance Condition is cleared when QERR (in Mode Page 0A) is 1.
 - DQue is set to 1 while queued command exist.

The unit attention condition persists for each initiator until that initiator clears the condition as described in the following paragraphs.

If the drive receives a command from each initiator before reporting a CHECK CONDITION status for a pending unit attention condition for that initiator, the response of the drive varies with the command as follows:

INQUIRY	The drive executes the command with GOOD status and preserves the unit attention condition.
REQUEST SENSE	If the drive has an available pending sense data for the initiator, the drive sends the pending sense data and preserves the unit attention condition for the initiator. If the drive does not have an available pending sense data for the initiator, the drive sends sense data for the unit attention condition and clears the unit attention condition for the initiator.
ALL OTHER	The drive terminates the command with a CHECK CONDITION status and preserves the unit attention condition.

If the drive receives a command from each initiator after reporting a CHECK CONDITION status for a pending unit attention condition for that initiator, the response varies with the command as follows:

REQUEST SENSE	The drive sends the sense data for a pending unit attention condition and returns GOOD status. And the drive clears the unit attention condition for the initiator.
ALL OTHER	The drive executes the command with GOOD status and clears the unit attention condition unless another unit attention condition exists. And then the sense data for the unit attention condition is lost.

11.1.6 Command Processing During Startup and Format Operations

If the Target receives a command from an Initiator while the Target is executing a startup or format operation, the response of the Target varies with the command as follows:

INQUIRY	The drive sends inquiry data and returns appropriate status.
REQUEST SENSE	Executes the command, returns a Sense key of NOT READY and an Additional Sense Code of LOGICAL UNIT NOT READY and returns GOOD STATUS. The Additional Sense Code Qualifier that is returned depends on type of I/O processes that are active: For the START/STOP UNIT and the Auto-start operation, the qualifier returned is LOGICAL UNIT IS IN PROCESS OF BECOMING READY. For the FORMAT UNIT command, the qualifier returned is LOGICAL UNIT NOT READY, FORMAT IN PROGRESS, and the Sense key specific bytes are set to return the progress indication.
ALL OTHER	The drive terminates the command with CHECK CONDITION status. The Sense data generated is described in Request Sense above.

11.1.7 Internal Error Condition

The Target generates an Internal Error condition for all Initiators when an internally initiated operation ends with an unrecoverable error, that is, the startup sequence for Auto Start enabled terminates after the SCSI bus has been enabled and prior to completion of the bring-up sequence.

An Internal Error condition causes Sense data to be generated and saved for all Initiators. The Error Code field of the Sense is set for a Current Error (70h) and the Sense Key is set to HARDWARE ERROR. Recovered errors are not reported.

The Internal Error condition persists for each Initiator until that Initiator clears the condition from the logical unit as described below. Several commands are handled as special cases during an Internal Error condition. These cases are also discussed.

If the Target receives a command from an Initiator while an Internal Error condition exists for that Initiator, the response of the Target varies with the command as follows:

INQUIRY	The drive executes the command with GOOD status and does not clear the Internal Error condition.
REQUEST SENSE	The drive executes the command, returns the sense data generated by the Internal Error condition, returns Good Status, and clears the Internal Error condition for that Initiator.
ALL OTHER	The drive terminates the command with a CHECK CONDITION status and clears the Internal Error condition.

11.1.8 Deferred Error

Error code (71h) of sense data indicates that the Check Condition status returned is the result of an error or exception condition that occurred during execution of a previous command for which Good status has already been returned.

The drive creates an Deferred Error condition when

- Execution of a Format Unit command with the immediate bit of one ends with an error.
- Execution of a Write command with WCE (Write Cache Enable) bit of one ends with an error.

11.1.9 Degraded Mode

There are certain errors or conditions which may impair the ability of the drive to function normally. Rather than fail hard the drive is designed to be as responsive as possible. Also, in most cases, some action on the part of the initiator may be used to restore normal operation. This mode of limited operation is called Degraded Mode.

There are 3 conditions in the Degraded Mode:

- Spindle Motor Degraded is caused by one of the following conditions:
 - Spindle Motor is not started by the option jumper setting (Disable Auto Spin Up)
 - Spindle Motor is delayed from spinning up by the option jumper setting (Auto Start Delay)
 - Spindle Motor was started (by POR or Unit Start command) and the Target is under Self Configuration.
 - Spindle Motor Failed to start.
 - Spindle Motor was stopped by Unit Stop command after the Target successfully completed the Self Configuration.
- Self Configuration Failure Degraded is caused by one of the following conditions:
 - RAM Code, Configuration Sector Read Failure
 - RAM Code, Configuration Sector Revision Mismatch
- Format Command Failure Degraded

This condition is caused when Format Unit command failed or was interrupted abnormally (Mode Page 0, byte 5, bit 4 FDD controls Format Degraded mode).

11.1.9 .1 Response to SCSI Command in Degraded Mode

The following tables show the degraded mode status with acceptable commands and additional sense codes.

Command (w/Option)	Response
Request Sense	Executed. The Target may return Sense Key 02h (Not Ready) ASC/ASCQ 0402h (Initialize Command Required)
Inquiry (EVPD=0)	Executed
Inquiry (EVPD=1)	Executed and Check Condition is returned with Sense Key 05h (Illegal Request) ASC/ASCQ 2400h (Invalid Field in CDB)
Test Unit Ready	Executed and Check Condition is returned with Sense Key 02h (Not Ready) ASC/ASCQ 0402h (Initialize Command Required)
Unit Start/Stop (Start)	Executed - Success: Good Status is returned. Motor Degraded Mode is cleared - Spindle Motor Start Failure: Check Condition with Sense Key 02h (Not Ready) ASC/ASCQ 0400h (Start Spindle Motor Fail) - Self Configuration Failure: Check Condition with Sense Key 02h (Not Ready) ASC/ASCQ 4080h (Diag Fail-Bring up Fail) Sense Key 02h (Not Ready) ASC/ASCQ 4085h (Diag Fail-RAM Code NOT load)
Unit Start/Stop (Stop)	Executed. Good Status is returned. Motor Degraded Mode is NOT cleared
Other Commands	Not Executed. Check Condition Status is returned with Sense Key 02h (Not Ready) ASC/ASCQ 0402h (Initialize Command Required)

Figure 179. Spindle Motor Degraded Mode - Disable Auto Start

Command (w/Option)	Response
Request Sense	Executed. The Target may return Sense Key 02h (Not Ready) ASC/ASCQ 0401h (In Process of Becoming Ready)
Inquiry (EVPD=0)	Executed
Inquiry (EVPD=1)	Executed and Check Condition is returned with Sense Key 05h (Illegal Request) ASC/ASCQ 2400h (Invalid Field in CDB)
Test Unit Ready	Executed and Check Condition is returned with Sense Key 02h (Not Ready) ASC/ASCQ 0401h (In Process of Becoming Ready)
Unit Start/Stop (Start)	Executed - Success: Good Status is returned. Motor Degraded Mode is cleared - Spindle Motor Start Failure: Check Condition with Sense Key 02h (Not Ready) ASC/ASCQ 0400h (Start Spindle Motor Fail) - Self Configuration Failure: Check Condition with Sense Key 02h (Not Ready) ASC/ASCQ 4080h (Diag Fail-Bring up Fail) Sense Key 02h (Not Ready) ASC/ASCQ 4085h (Diag Fail-RAM Code NOT load)
Other Commands	Not Executed. Check Condition Status is returned with Sense Key 02h (Not Ready) ASC/ASCQ 0401h (In Process of Becoming Ready)

Figure 180. Spindle Motor Degraded Mode - Auto Start Delay/Spinning Up

Command (w/Option)	Response
Request Sense	Executed. The Target may return Sense Key 02h (Not Ready) ASC/ASCQ 0400h (Start Spindle Motor Fail)
Inquiry (EVPD=0)	Executed
Inquiry (EVPD=1)	Executed and Check Condition is returned with Sense Key 05h (Illegal Request) ASC/ASCQ 2400h (Invalid Field in CDB)
Test Unit Ready	Executed and Check Condition is returned with Sense Key 02h (Not Ready) ASC/ASCQ 0400h (Start Spindle Motor Fail)
Unit Start/Stop (Start)	Executed - Success: Good Status is returned. Motor Degraded Mode is cleared - Spindle Motor Start Failure: Check Condition with Sense Key 02h (Not Ready) ASC/ASCQ 0400h (Start Spindle Motor Fail) - Self Configuration Failure: Check Condition with Sense Key 02h (Not Ready) ASC/ASCQ 4080h (Diag Fail-Bring up Fail) Sense Key 02h (Not Ready) ASC/ASCQ 4085h (Diag Fail-RAM Code NOT load)
Unit Start/Stop (Stop)	Executed. Good Status is returned. Motor Degraded Mode is NOT cleared
Other Commands	Not Executed. Check Condition Status is returned with Sense Key 02h (Not Ready) ASC/ASCQ 0400h (Start Spindle Motor Fail)

Figure 181. Spindle Motor Degraded Mode - Spindle Start Failure

Command (w/Option)	Response
Request Sense	Executed. The Target may return Sense Key 02h (Not Ready) ASC/ASCQ 0402h (Initialize Command Required)
Inquiry (EVPD=0)	Executed
Inquiry (EVPD=1)	Executed
Test Unit Ready	Executed and Check Condition is returned with Sense Key 02h (Not Ready) ASC/ASCQ 0402h (Initialize Command Required)
Unit Start/Stop (Start)	<p>Executed</p> <ul style="list-style-type: none"> - Success: Good Status is returned. Motor Degraded Mode is cleared - Spindle Motor Start Failure: Check Condition with Sense Key 02h (Not Ready) ASC/ASCQ 0400h (Start Spindle Motor Fail) - Self Configuration Failure: Check Condition with Sense Key 02h (Not Ready) ASC/ASCQ 4080h (Diag Fail-Bring up Fail) <p>Sense Key 02h (Not Ready) ASC/ASCQ 4085h (Diag Fail-RAM code NOT load)</p>
Unit Start/Stop (Stop)	Executed. Good Status is returned. Motor Degraded Mode is NOT cleared
Other Commands	Not Executed. Check Condition Status is returned with Sense Key 02h (Not Ready) ASC/ASCQ 0402h (Initialize Command Required)

Figure 182. Spindle Motor Degraded Mode - Spindle Stopped by Unit Stop Command

Command (w/Option)	Response
Request Sense	Executed. The Target may return Sense Key 02h (Not Ready) ASC/ASCQ 4080h (Diag Fail-Bring up Fail) Sense Key 02h (Not Ready) ASC/ASCQ 4085h (Diag Fail-RAM code NOT load)
Inquiry (EVPD=0)	Executed
Inquiry (EVPD=1)	Executed and Check Condition is returned with Sense Key 05h (Illegal Request) ASC/ASCQ 2400h (Invalid Field in CDB)
Test Unit Ready	Executed and Check Condition is returned with Sense Key 02h (Not Ready) ASC/ASCQ 4080h (Diag Fail-Bring up Fail) Sense Key 02h (Not Ready) ASC/ASCQ 4085h (Diag Fail-RAM code NOT load)
Unit Start/Stop (Start)	Executed - Success: Good Status is returned. Motor Degraded Mode is cleared - Spindle Motor Start Failure: Check Condition with Sense Key 02h (Not Ready) ASC/ASCQ 0400h (Start Spindle Motor Fail) - Self Configuration Failure: Check Condition with Sense Key 02h (Not Ready) ASC/ASCQ 4080h (Diag Fail-Bring up Fail) Sense Key 02h (Not Ready) ASC/ASCQ 4085h (Diag Fail-RAM code NOT load)
Write Buffer (Download and Save)	Executed. - Success: Good Status is returned. Motor Degraded Mode is cleared - Self Configuration Failure: Check Condition with Sense Key 02h (Not Ready) ASC/ASCQ 4080h (Diag Fail-Bring up Fail) Sense Key 02h (Not Ready) ASC/ASCQ 4085h (Diag Fail-RAM code NOT load)
Other Commands	Not Executed. Check Condition Status is returned with Sense Key 02h (Not Ready) ASC/ASCQ 4080h (Diag Fail-Bring up Fail) Sense Key 02h (Not Ready) ASC/ASCQ 4085h (Diag Fail-RAM code NOT load)

Figure 183. Self Configuraion Failure Degraded Mode

Command (w/Option)	Response
Request Sense	Executed. The Target may return Sense Key 02h (Not Ready) ASC/ASCQ 3100h (Format Corrupted) Sense Key 03h (Medium Error) ASC/ASCQ 3100h (Format Corrupted)
Inquiry (EVPD=0)	Executed
Inquiry (EVPD=1)	Executed
Test Unit Ready	Executed and Check Condition is returned with Sense Key 02h (Not Ready) ASC/ASCQ 3100h (Format Corrupted)
Format Unit	Executed - Success: Good Status is returned. Format Degraded Mode is cleared - Failure: Check Condition Status is returned and Format Degraded Mode is NOT cleared.
Other Commands	Not Executed. Check Condition Status is returned with Sense Key 03h (Medium Error) ASC/ASCQ 3100h (Format Corrupted)

Note: Mode Page 0 byte 5 bit 4 (FDD) = 0

Figure 184. Format Command Failure Degraded Mode

11.1.10 Command processing while reserved

A logical unit is reserved after successful execution of the Reserve command. Each time a Reserve command is executed successfully, the Target records the SCSI ID of the Initiator that made the reservation and the SCSI ID of the Initiator that is to receive the reservation. This information is needed to determine whether subsequent commands should be permitted or if the Reservation Conflict Status should be reported. The Initiator that made the reservation is the Initiator that issued the Reserve command. The Initiator to receive the reservation may be either the same or a different Initiator (third-party reservation).

If the logical unit is reserved when a new command is received, the Target examines the command opcode and the SCSI ID of the issuing Initiator to determine whether a Reservation Conflict Status should be returned based on the following rules:

1. If the issuing Initiator is the one that made the reservation and also the one to receive the reservation, then all commands are permitted.
2. If the issuing Initiator is neither the one that made the reservation nor the one to receive the reservation then
 - A Request Sense or Inquiry command is permitted.
 - A Release command is permitted but is ignored
 - Any other command results in a Reservation Conflict Status.

3. If the issuing Initiator is the one that made the reservation but is not the one to receive the reservation then

- An Inquiry, Request Sense, Reserve, or Release command is permitted.
- Any other command results in a Reservation Conflict Status.

11. If the issuing Initiator is not the one that made the reservation but is the one to receive the reservation then

- A Reserve command results in a Reservation Conflict Status.
- A Release command is permitted but is ignored.
- Any other command is permitted.

If a Reservation Conflict Status is not reported and the command is permitted, then the Target checks the next highest priority internal condition to determine whether execution is allowed. See 11.1.1, "Priority of SCSI Status Byte Reporting."

11.2 Priority commands

Certain SCSI commands always execute without returning a Busy Status or Reservation Conflict Status in response to the command. These commands are

- Inquiry
- Request Sense

These commands do not disconnect from the SCSI bus prior to completion. They are executed prior to attempting to complete the execution of any other pending command that has disconnected from the SCSI bus. Therefore, a second priority command cannot be received during the execution of a priority command.

These commands are never queued whether or not the command is sent with a queue tag. However, the rule for an Incorrect Initiator Connection still apply to priority commands. See 11.1.3, "Incorrect Initiator Connection."

11.3 Command queuing

When the initiator specifies that the drive shall disable command queuing, the initiator must send only untagged commands. When the initiator specifies that the target shall enable command queuing, the initiator may send either tagged or untagged command, but shall not use both at the same time.

The following commands are never queued and will be immediately executed without Bus disconnection:

- Priority Commands (i.e.: Request Sense and Inquiry)
- Commands linked to previous commands. These are defined to be part of a single I/O process. (Linked commands are always executed immediately following the previous command from the same initiator. No other Initiator's command are allowed to be executed between two linked commands.)
- Commands for which disconnection is not allowed. (These may result in a Busy Status.)
- Commands in which a SCSI bus error occurred between selection and first disconnection following the receipt of the CDB.

- Commands for an invalid LUN.
- Commands which cause an OVERLAPPED COMMANDS ATTEMPTED error (see 11.1.3, “Incorrect Initiator Connection”).

11.3.1 Queue depth

Any initiator can queue at least one command at any time irrespective of the actions of any other initiators in the system. A single initiator may queue up to 128 commands, if no other initiator has more than one command in the queue, although at times this maximum may be reduced as the drive can reserve command blocks for internal use.

11.3.2 Tagged queuing

Commands with a tag message are saved in the command queue. Queued commands will be reordered by the target defined rule. See the section on Reordering 11.4 “Command reordering” for details.

11.3.3 Untagged queuing

The target supports queuing one I/O process from each initiator. If the target receives an untagged I/O process while executing an I/O process from a different initiator, the untagged I/O process may be queued.

Untagged I/O processes are treated by the target as though they were received with Simple Queue Tag messages for purposes of queuing.

Note: There is no guarantee that I/O processes are executed in the order they were received in a multiple initiator environment when Untagged Queuing is enabled.

11.3.4 Command queuing rule

Commands can be received during an active I/O process if the Bus is free. If CPE (concurrent process enable) bit of Mode page 0 is 0, only a single command except 2 commands (Inquiry and Request Sense) can be executed at the same time. In that case, a command starts to be executed after the previous command has completed. If CPE (concurrent process enable) bit of Mode page 0 is 1, I/O processes of Read(6), Read extend(10), Write(6) and Write extend(10) can be active at the same time. See **Concurrent I/O Process** on page 239 for details.

11.3.5 Queue Full status

This status is returned when a Simple Queue tag, Ordered Queue tag or Head of Queue tag message is received and the command queue is full. The I/O process is not placed in the command queue. Since one queue element is reserved for each initiator, any untagged command that does not cause Incorrect Initiator Connection will not cause Queue Full status.

11.3.6 Device behavior on Command queuing

1. Initiators must send a Queue tag immediately after the Identify message in Message Out phase just after Selection. Targets send a simple queue tag immediately after the Identify message in Message In phase just after Reselection.
2. Each initiator can issue either a tagged command or an untagged command exclusively at the same time. Other initiators can exist which operate mutually exclusively with tagged or untagged commands
3. When DQue (Disable queue) of mode page 0Ah is 1, if an initiator issues a tagged command, the drive returns "Message Reject" message (07h) and receives that command as an untagged command.

4. Queue Tag number does not affect the order of execution.
5. If an initiator issues a command with a queue tag which is the same as the current I/O process or queued I/O process. The target returns Incorrect Initiator connection.
6. A series of linked commands are a single I/O process and are assigned the queue tag established in the initial selection. A command received with a Head-of-Queue tag message shall not suspend a series of linked commands for which the target has begun execution.
7. If DQue is changed to 1 while queued commands exist, all queued commands for the all initiators will be aborted. All future commands received from any initiator with a queue tag will be processed as untagged commands with a message reject message being returned immediately after the qtag is received by the target.

11.4 Command reordering

Command reordering function is supported under tagged command queuing enabled (DQue = 0). The re-order feature reorders Read/Write commands in order to minimize seek time between commands. This function will improve total throughput of the drive.

11.5 Concurrent I/O Process

The Concurrent I/O process when multiple I/O processes are active (not queued) on the same logical unit at the same time. The target may start the data phase of an I/O process while another I/O process is not completed. The following I/O processes are allowed to execute concurrently:

- Unlinked and untagged Request Sense and Inquiry during execution of other commands.
- When CPE (Concurrent process enable) bit is one, one of the following commands can be executed while another one or the same one of the following commands is being executed, if those are untagged or simple tagged commands.
 - Read(6), Read extend(10)
 - Write(6), Write extend(10)

When an I/O process ends in Check Condition Status, the drive enters the Contingent Allegiance Condition and other queued I/O processes from all initiators on the same logical unit will not reconnect and will not complete the execution until the sense data is cleared. See 11.16, "Contingent allegiance Condition," for details. If an I/O process (P-1) encounters an error while another I/O process (P-2) is active, the drive returns Check Condition to P-1 and P-2. The drive may continue P-2 until its convenient point to suspend, but may not send a Status. After the initiator clears the Contingent Allegiance condition, the drive will resume or terminate P-2 according to QErr bit of Control mode page.

If the drive gets an error on P-2 before suspending the execution of P-2, it will keep the sense data separately from the sense data for P-1. The sense data for P-2 will be set after the Contingent Allegiance condition caused by P-1 is cleared.

11.6 Back to Back Write

Back to Back Write allows plural write commands requesting sequential LBA's to be written without losing a motor revolution.

11.7 Write Cache

If the WCE (Write cache enable) bit is 1, the drive returns Good Status and Command Complete message and goes to Bus Free immediately after receiving the data of the last sector before actually writing the data onto the media.

If the drive detects an error after it returns a Good Status, the drive sets a Deferred Error (Error Code of sense data = 71h) and a following command will be returned with Check Condition and the Contingent allegiance condition is established. Under the Contingent allegiance condition all queued processes including commands from other initiators are suspended.

11.8 Automatic Rewrite/Reallocate

The target supports Auto and Recommended Reallocate for READ, WRITE, WRITE VERIFY, and VERIFY.

Automatic and Recommend Reallocate operate from within the read/write command. When an automatic reallocation occurs, the read or write command takes longer to complete.

This operation is sometimes referred to as auto-reassignment due to its similarity to the operation performed by the reassign command.

Following is a description of the target behavior for each setting of ARRE. ARRE setting affects all data errors. (No Sector Found, Data Sync Byte Errors and Data ECC Errors.)

ARRE=1: An error site determined to need rewriting or reallocation during a read is automatically rewritten or reallocated at the conclusion of the read and prior to the sending of the status. The site will be automatically rewritten or reallocated only if the data has been successfully read.

ARRE=0: An error site determined to need rewriting or reassignment during a read is recommended for rewriting or reassignment at the conclusion of the read.

The setting of the ARRE bit is checked and the target will automatically rewrite/reallocate or recommend rewrite/reassign for the following commands.

- Read(6)
- Read(10)
- Verify
- Verify Portion of Write and Verify

For all other commands the ARRE setting is ignored and the target will not automatically rewrite/reallocate or recommend rewrite/reassign.

Following is a description of the target behavior for each setting of AWRE. AWRE setting effects only No Sector Found Errors on writes.

AWRE=1 : An error site determined to need reassignment during a write is automatically reallocated at the conclusion of the write and prior to sending the status. The site will be automatically reallocated only if the write recovery succeeded at the conclusion of the write.

AWRE=0 : An error site determined to need reassignment during a write is recommended for reassignment at the conclusion of the write.

The setting of the AWRE bit is checked and the target will automatically reallocate or recommend reassign for the following commands.

- Write(6)

- Write(10)
- Write portion of Write and Verify

For all other commands the AWRE setting is ignored and the target will not automatically reallocate or recommend reassign.

Auto/Recommend Reallocate information is communicated via the sense data returned following a command during which a site was determined to need rewriting or reassignment. The LBA returned in the sense data is the LBA that was determined to need rewriting or reassignment.

The sense data combinations with auto/recommend rewrite/reallocate are listed below.

Key	Code	Qual	Description
1	17	01	Recovered Data with retries
1	17	06	Recovered Data without ECC - Auto Reallocated
1	17	07	Recovered Data without ECC - Recommend Reassign
1	17	09	Recovered Data without ECC - Data Rewritten
1	18	00	Recovered Data with ECC
1	18	02	Recovered Data with ECC - Auto Reallocated
1	18	05	Recovered Data with ECC - Recommend Reassign
1	18	07	Recovered Data with ECC - Data Rewritten

Figure 185. Sense data combinations with auto/recommend rewrite/reallocate

11.9 Segmented Caching

11.9.1 Overview

Segmented Caching divides the data buffer into several smaller buffers. Each buffer is used as Read/Write/Read-Ahead buffer.

11.9.2 Read Ahead

The Read Ahead function consists of reading data that the Initiator has not yet requested to the drive buffer. This function is intended to improve performance for an initiator that frequently accesses sequential data with successive SCSI read commands. The Read Ahead function works when RCD (the read cache disable) bit of read cache page (page 08h) is set to zero.

The drive initiates the Read ahead function when

- RCD is 0, and
- Read(6), Read extended(10), Read Verify, and Write and Verify is received, and
- The consecutive LBA of the requested LBA is not available in the buffer.

If SCSI reset or bus device reset message is received, all contents of segmented buffer is flushed.

Even if an error occurs during the Read ahead, the error will not be reported to the Initiator. The data read before the error occurred will be stored as valid data by the Read Ahead function.

11.10 Reselection Timeout

If reselection fails, it will be retried one or more times depending on the drive model. Please see the individual drive specifications for the number of retries allowed.

11.11 Single Initiator Selection

For single initiator systems it is not an error to have only the target ID bit present during selection. Disconnection is not allowed for Single Initiator Selection with only one ID bit present during selection. The initiator must not send an Identify message with the disconnect permission bit(6) on.

11.12 Non-arbitrating systems

The Target cannot detect whether other SCSI devices on the SCSI bus use arbitration prior to selection. As a consequence the Target allows disconnect permission to be enabled by the Identify message independent of the initiator's use of arbitration prior to selection. A non-arbitrating initiator must ensure that disconnect permission in the Identify message is disabled (bit 6=0) for proper operation.

11.13 Selection without ATN

If the target is selected without ATN signal active, no Identify message is received from the Initiator. In this case the LUN is identified from the CDB and disconnect permission is disabled. The target does not perform any phase retries. The target still responds to a subsequent attention condition. However the LUN is not considered to be known if a fatal error is detected during the Command phase. That is a Command phase parity error or a fatal message error in response to attention condition during Command phase is handled as a Bus Free error with no sense data. The target also knows the use of linked commands if selected without ATN.

Phase retries may be allowed if a subsequent Identify message is received.

11.14 Multiple Initiator Environment

11.14.1 Initiator Sense Data

Separate sense data is reserved for each I-T-L. Each sense data is maintained independent of commands from other initiators.

11.14.2 Initiator Mode Select/Mode Sense Parameters

A single shared copy of the Mode Select/Mode Sense parameters is maintained by the drive. This includes both the current and saved parameters.

11.14.3 Initiator Data Transfer Mode Parameter

A separate data transfer mode parameters area is reserved and maintained for each initiator.

11.15 Contingent Allegiance Condition

The contingent allegiance condition shall exist following the return of Check Condition, except for a Check Condition caused by Invalid LUN. Execution of all queued commands shall be suspended until the contingent allegiance condition is cleared.

The contingent allegiance condition can be cleared by the initiator in one of the following ways:

- By issuing a REQUEST SENSE command to the Target and receiving the sense data. This is the recommended way.
- By issuing any other command to the I_T_x nexus that reported the fault.
- By issuing an Abort message to the I_T_x nexus that reported the fault. This will also abort the current and queued I/O process from that initiator.
- By issuing a Bus Device Reset message to the Target. This will also abort all current and queued I/O processes.
- By generating a RESET condition on the bus. This MUST be the last resort.

11.16 Reset

The Reset condition is used to clear all SCSI devices from the bus. This condition takes precedence over all other phases and conditions. After a reset condition is detected and the reset actions completed, the target returns to a 'SCSI bus enabled' state that allows the target to accept SCSI commands.

This device uses the Hard reset option as defined in the SCSI-3 standard.

11.16.1 Reset Sources

There are four sources of resets detected by the target:

Reset Name	Reset Source
Power-On Reset	This is the signal generated by the hardware at initial power-on
Self-Initiated reset	This is a software-generated reset that occurs when a catastrophic error is detected by the microcode.
SCSI Bus Reset	This is a reset generated when the SCSI bus control line RST goes active.
SCSI Bus Device Reset Message	This is the reset generated by the SCSI Bus Device Reset Message(0Ch).

11.16.2 Reset Actions

The action taken by the drive following a reset is dependent on the source of the reset.

11.16.2 .1 Power-On reset and Self-Initiated reset

These two reset conditions cause the following to be performed in the order shown:

1. A power-up sequence
2. A startup sequence is necessary to put the drive in a ready state

11.16.2 .2 SCSI Bus reset and SCSI Bus Device Reset message

These two reset conditions cause the following to be performed.

- If reset goes active while the power-up sequence is in progress, the power-up sequence is started over.
- If the Auto Start pin is grounded and a startup sequence has not yet completed, a startup sequence will be re-attempted from the beginning.

Note: The power-up sequence, having already completed, is not rerun.

- If reset occurs while a physical sector is being written, the write operation is disabled after the current physical sector is written. Data is not lost as long as power stays valid until the physical sector being written is completed.

11.17 Diagnostics

The drive will execute a self test at power on or when a Send Diagnostics command is issued with the self test bit set.

The diagnostics are to assure the correct operation of the drive and to verify that the check circuits detect fault conditions.

11.17.1 Power on Diagnostics

At power on time the following tests are executed:

1. ROM code verification.
2. RAM size verification.
3. Test and Initialize HDC registers.
4. Sector buffer RAM read/write test.
5. Sector buffer clean up.
6. Start spin-up (if Auto-spin enable).
7. Release actuator.
8. Calibration.
9. Read reserved data for RAM code and data table.
10. Activate RAM code.
11. RDM/LOG/MODE table verification.

11.17.2 Diagnostics Command

The tests executed as a result of the Send Diagnostics command with the self test bit set to one differs from the tests executed at power on. The spindle motor must be at the correct speed for the Diagnostics command to be executed. If the motor is not at the correct speed, a NOT READY status will be returned in the sense byte.

The Diagnostics command will execute the following tests:

1. Test the adapter section of the drive as follows:
 - a. Assure the ECC circuits work correctly.
 - b. Do a read/write test on sector buffer RAM.
2. Check the RPM of the spindle.
3. Seek a correct cylinder.
4. Write to a certain area in reserved area.
5. Read from the area.

11.17.3 Diagnostics Fault Reporting

Faults detected before successful completion of the adapter section could prevent the drive from responding to a selection.

Faults detected after the successful completion of the adapter section will be reported as Check Condition status to the initiator on the first command issued after a fault is detected except for the Inquiry command. The Inquiry command will always respond with good status. Detecting a fault during power on will not terminate execution of the diagnostics nor will it terminate the power on process.

Faults detected during a Send Diagnostics command will report a Check Condition as end status.

11.18 Idle Time Function

The drive periodically saves data in logs and PFA counters in the reserved area of the disks. The information is used by the drive to support various SCSI commands and for the purpose of failure analysis. This is performed if the drive has not received a SCSI command for 10 minutes. The execution time is about 300mS.

12.0 SCSI Sense Data

12.1 SCSI Sense Data Format

Format of the sense data returned by the drive in response to the REQUEST SENSE command.

Byte	Bit							
	7	6	5	4	3	2	1	0
0	Valid	Error Code (70h or 71h)						
1	RSVD = 0							
2	0	ILI	0	Sense Key				
3-6	(MSB) Information Bytes							(LSB)
7	Additional Sense Length							
8-11	(MSB) Product Specific Information							(LSB)
12	Additional Sense Code							
13	Additional Sense Code Qualifier							
14	FRU = 0							
15	SKSV	Sense-Key Specific Bits						
16-17	Sense-Key Specific Bytes							
18-19	Reserved = 0							
20-23	Vendor unique Error information							
24-29	Product Specific Information							
30-31	Reserved = 0							

Figure 186. Format of Sense Data.

12.2 Sense Data Description

12.2.1 Valid (Bit 7 of byte 0)

- 0 The Information Bytes (byte 3 through 6) are not defined.
- 1 The Information Bytes (byte 3 through 6) contain a valid logical block address.

12.2.2 Error Code (Bit 6 - 0 of byte 0)

- 70h Current Error. This indicates an error for the current command.
- 71h Deferred Error. This indicates that the error is for a previous command that has already returned a good status. Such commands are associated with the immediate bit or write caching.
Format unit (04h) command is an example of a command that may return a deferred error.

12.2.3 ILI: Incorrect Length Indicator (Bit 5 of byte 2)

The ILI bit is valid for the Read Long (3Eh) command and Write Long (3Fh) command only. ILI set to one and Valid Bit set to one indicates that the requested logical block length does not match the logical block length of the data on the medium for a Read Long or Write Long command. The Information field contains residue information about the error. ILL set to zero indicates there is no incorrect length condition.

- 0 No Incorrect Length condition.
- 1 Incorrect Length Indicated.

12.2.4 Sense Key (Bit 3 - 0 of byte 2)

The sense key provides generic categories in which error and exception conditions can be reported. Initiators would typically use sense keys for high level error recovery procedures.

- 0h **No Sense**
There is no sense key information to be reported for the logical unit.
- 1h **Recovered Error**
The last command completed successfully with some recovery action performed by the drive. More detailed information is available in the Additional Sense Code and Additional Sense Code Qualifier.
- 2h **Not Ready**
The logical unit addressed cannot be addressed. More detailed information is available in the Additional Sense Code and Additional Sense Code Qualifier.
- 3h **Medium Error**
The command terminated with an unrecoverable error condition caused by a flaw in the media or an error in the recorded data. More detailed information is contained in the Additional Sense Code and Additional Sense Code Qualifier.
- 4h **Hardware Error**
The drive detected a unrecoverable hardware error while performing a command or during a diagnostic test. More detailed information is contained in the Additional Sense Code and Additional Sense Code Qualifier.

5h	Illegal Request There was an illegal parameter in the command descriptor block or additional parameter supplied as data. If an invalid parameter is found in the CDB, then the command is terminated without altering the medium. If an invalid parameter is found in parameters supplied as data, then the drive might have altered the medium.
6h	Unit Attention Indicates that the drive entered in the 'Unit Attention Condition'. (See 11.1.5, "Unit Attention Condition" on page 205.)
7h-8h	Not used
9h	Vendor Specific
Ah	Not used
Bh	Aborted command The drive aborted the command.
Ch-Dh	Not Implemented
Eh	Not Used
Fh	Reserved

12.2.5 Information Bytes (Byte 3 through 6)

This field is only valid when Valid Bit is one.

- **ILI = 0** : This field contains the unsigned LBA associated with the sense key. The LBA reported will be within the LBA range of the command as defined in the CDB.
Note: An LBA other than the command LBA may be reported on the Reassign Block (07h) command.
- **ILI = 1** : This field contains the difference (residue) of the requested length in bytes. Negative values are indicated by two's complement notation.

12.2.6 Additional Sense Length (Byte 7)

Indicates the remaining number of bytes in the sense data. (It is always set to 18h.)

12.2.7 Command Specific Information (Byte 8 through 11)

The values in this field vary with products. Please see the individual product specification for more details.

12.2.8 Additional Sense Code/Qualifier (Byte 12 and 13)

The following table shows the description of the combination of Sense Key / Sense Code / Qualifier.

Key	Code	Qual	Description
0	0	0	No error
0h	5Dh	00h	No sense. Predictive Failure Analysis threshold reached
1h	01h	00h	Recovered write error no index
1h	02h	00h	Recovered no seek comp
1h	03h	00h	Recovered write error. Write fault
1h	0Bh	01h	Temperature Warning
1h	0Ch	01h	Recovered write error with Auto-reallocation. Auto Reallocated
1h	0Ch	03h	Recovered write error. Recommend Reassign
1h	14h	01h	Recovered Record Not Found
1h	16h	00h	Recovered write error DAM not found
1h	17h	01h	Recovered read error with retries
1h	17h	06h	Recovered read error without ECC applied. Auto reallocated
1h	17h	07h	Recovered read error without ECC applied. Recommended reassign. This value can be returned only when ARRE = 0
1h	17h	09h	Recovered read error without ECC applied. Data rewritten. This value can be returned only when ARRE = 1
1h	18h	00h	Recovered read error with ECC applied. This value can be returned only when ARRE = 0
1h	18h	02h	Recovered read error with ECC applied. Auto reallocated
1h	18h	05h	Recovered read error with ECC applied. Recommended reassign
1h	18h	07h	Recovered read error with ECC applied. Data Rewritten
1h	1Ch	01h	Primary Defect List Not Found. Requested Defect List Format is not supported. Default List Format is returned (Read Defect Data Only)
1h	1Ch	02h	Grown Defect List Not Found. Requested Defect List Format is not supported. Default List Format is returned (Read Defect Data Only)
1h	1Fh	00h	Partial Defect List Transferred. Defect list longer than 64KB, 64KB of data returned. (Read Defect Data Only)
1h	44h	00h	Internal target failure
1h	81h	00h	Internal logic error
1h	5Dh	00h	Predictive Failure Analysis threshold reached
1h	5Dh	FFh	Predictive Failure Analysis Test Warning

Figure 187. Sense Key / Sense Code / Qualifier combinations continued on next page.

Key	Code	Qual	Description
2h	04h	00h	Not ready. Start spindle motor fail.
2h	04h	01h	Not ready. In process of becoming ready.
2h	04h	02h	Not ready. Initializing command required. (Start Unit)
2h	04h	04h	Not ready. Format in progress.
2h	04h	09h	Not ready. Self-test in progress.
2h	31h	00h	Not ready. Medium format corrupted.
2h	40h	80h	Diag Fail - Bring-Up Fail.
2h	40h	85h	Diag Fail - RAM Microcode Not Loaded.
3h	03h	00h	Medium error. Write fault.
3h	10h	00h	Medium error. ID CRC error.
3h	11h	00h	Medium error. Unrecovered read error.
3h	14h	01h	Medium error. Record not found.
3h	16h	00h	Medium error. Data synchronization mark error. (DAM error)
3h	19h	00h	Medium error. Defect list error. A defect list error occurs when a data error is detected while reading the manufacturing defect list or while reading or writing the grown defect list.
3h	31h	00h	Medium error. Medium format corrupted.
4h	01h	00h	Hardware error. No index or sector.
4h	02h	00h	Hardware error. No seek complete.
4h	03h	00h	Hardware error. Write fault.
4h	11h	00h	Hardware error. Unrecovered read error in reserved area.
4h	19h	00h	Hardware error. Defect list error.
4h	32h	00h	Hardware error. No defect spare location available. A "no defect spare location available sense code" indicates that the Reassign Block command can not proceed the process because all spare sectors have been used, or it will exceed implementation limitation of defect handling of the file.
4h	3Eh	03h	Hardware error. Self-test failed.
4h	3Eh	04h	Hardware error. Unable to update self-test.
4h	40h	80h	Degrade Mode. Diagnostic Fail. Configuration sector valid check fail. Reserved area sector valid check fail.
4h	40h	85h	Degrade Mode. RAM Microcode Not Loaded.
4h	44h	00h	Hardware error. Buffer CRC Error on Write.
4h	81h	00h	Hardware error. Internal logic error.
4h	82h	00h	Hardware error. Command timeout.

Figure 179. Sense Key / Sense Code / Qualifier combinations continued on next page.

Key	Code	Qual	Description
5h	1Ah	00h	Illegal request. Parameter list length error. The number of parameters supplied is not equal to the value expected.
5h	20h	00h	Illegal request. Illegal command operation code. This command is also returned when an unsupported command code is received.
5h	21h	00h	Illegal request. Logical block address out of range.
5h	24h	00h	Illegal request. Invalid field in CDB
5h	25h	00h	Illegal request. Invalid lun
5h	26h	00h	Illegal request. Invalid fields in the parameter list
5h	26h	02h	Parameter value invalid
5h	2Ch	00h	Illegal request. Echo buffer being read before being written
6h	28h	00h	Unit attention. Not ready to ready transition. (Format completed)
6h	29h	01h	Unit attention. Power On Reset occurred
6h	29h	02h	Unit attention. SCSI Bus Reset occurred
6h	29h	03h	Unit attention. Bus Device Reset occurred
6h	29h	04h	Unit attention. Self Initiated Reset occurred
6h	29h	05h	Unit attention. Transceiver mode change to SE
6h	29h	06h	Unit attention. Transceiver mode change to LVD
6h	2Ah	00h	Unit attention. Parameters changed
6h	2Ah	02h	Unit attention. Log select parameters changed
6h	2Fh	00h	Unit attention. Command cleared by another initiator
6h	3Fh	01h	Unit attention. Micro code has been changed
6h	5Dh	00h	Predictive Failure Analysis threshold reached
6h	5Dh	FFh	Predictive Failure Analysis Test Warning

Figure 179. Sense Key / Sense Code / Qualifier combinations continued on next page.

Key	Code	Qual	Description
Bh	1Bh	00h	Aborted command. Synchronous data transfer error. (Extra ack detected)
Bh	25h	00h	Aborted command. Unsupported LUN. The drive supports LUN 0 only
Bh	3Fh	00h	Aborted command. Echo buffer overwritten
Bh	43h	00h	Aborted command. Message reject error. A message reject error occurs when an inappropriate or unexpected message reject is received from the initiator or the initiator rejects a message twice
Bh	44h	00h	Aborted command. Buffer CRC Error on Read
Bh	45h	00h	Aborted command. Selection/Reselection failed. A selection/reselection error occurs when the initiator fails to respond to a reselection within 250 milliseconds after the drive starts reselection. The reselection is attempted a second time before setting selection/reselection failed sense code
Bh	47h	00h	Aborted command. SCSI parity error
Bh	48h	00h	Aborted command. Initiator detected error message received. An initiator detected error occurs when the initiator detects an error, sends a message to retry, detects the error again, and sends the retry message a second time. The drive then sets check condition status with Initiator Detected Error
Bh	49h	00h	Aborted command. Inappropriate/illegal message. An inappropriate or illegal message occurs when the initiator sent a message that either is not supported or is not in a logical sequence
Bh	4Eh	00h	Aborted command. Overlapped commands attempted

Figure 279. concluded.

12.2.9 FRU : Field Replaceable Unit (Byte 14)

The FRU (Field Replaceable Unit) field value will always be zero.

12.2.10 Sense Key Specific (Byte 15 through 17)

The definition of this field is determined by the value of the sense key field.

12.2.10.1 Sense Key Specific - Illegal Request (Sense Key = 5h)

Error field pointer is returned.

Byte	Bit							
	7	6	5	4	3	2	1	0
15	SKSV	C/D	Reserved		BPV	Bit Pointer		
16 17	(MSB) Field Pointer							(LSB)

Figure 188. Field Pointer Bytes

SKSV	Sense-key specific valid
0	Sense-key specific field is not valid.
1	Sense-key specific field is valid.
C/D	Command/Data
0	Indicates that the illegal parameter was in the data parameters sent by the initiator during DATA OUT phase
1	Indicates that the illegal parameter in the command descriptor block.
BPV	Bit Pointer Valid
0	Bit pointer field is not valid.
1	Bit pointer field is significant.
Bit Pointer	Indicates which bit of the byte number reported in Field Pointer is the bit in error. When a multiple bit field is in error, the pointer points to the most significant bit of the field.
Field Pointer	Indicates which bytes of the command descriptor block or of the parameter data were in error. Bytes are numbered starting from zero, as shown in the tables describing the commands and parameters. When a multiple byte field id is in error, the pointer points to the most significant byte of that field.

12.2.10.2 Sense Key Specific - Recovered (Sense Key = 1h)

Hardware (Sense Key = 4h) or Medium Error (Sense Key = 3h)

Actual Retry Count is reported.

Byte	Bit							
	7	6	5	4	3	2	1	0
15	SKSV	Reserved						
16 17	(MSB)	Actual Retry Count						(LSB)

Figure 189. Actual Retry Count

SKSV Sense-key specific valid
0 Actual Retry Count is not valid.
1 Actual Retry Count is valid.

Actual Retry Count Actual number of retries used in attempting to recover from the error condition.

12.2.10.3 Sense Key Specific - Not Ready (Sense key = 2h)

These fields are defined for the Format unit (04h) command with the Immediate bit set to one and the Send Diagnostics (1Dh) command with Foreground self-test function. Progress indication is returned.

Byte	Bit							
	7	6	5	4	3	2	1	0
15	SKSV	Reserved						
16 17	(MSB)	Progress Indication						(LSB)

Figure 190. Progress Indication

SKSV Sense-key specific valid
0 Progress Indication is not valid.
1 Progress Indication is valid.

Progress Indication Indicates a percent complete in which the returned value is the numerator that has 10000h as its denominator.

12.2.11 Reserved (Byte 18 through 19)

Reserved fields are filled with zero.

12.2.12 Vendor unique error information (Byte 20 through 23)

This field gives detailed information about the error. It contains a unique code which describes where the error was detected and which piece of hardware or microcode detected the error depending on current operation (i.e. Power On Reset/Initialization, Read/Write operation, or SMART Alert).

12.2.12.1 Power On Reset/Initialization Error (Sense Key 02h)

While Power On Reset/Initialization is in process, Sense Key 02h "Not Ready" is a possible failure and the Vendor Unique Error information bytes 20 and 21 will contain "POR Step" which indicates where the failure was detected during the microcode processing, and the Vendor Unique Error information bytes 22 and 23 will contain "POR Error" which is the reason for failure.

Sense Data Byte 20	Description
Bit.7	Jumper Setting - Disable Auto Spin-Up
Bit.6	Format Corrupted - Degraded Mode
Bit.5	Soft Reset Occurred
Bit.4	RAM ERP Not Ready
Bit.3	Not Used
Bit.2	Not Used
Bit.1	Start Spinning
Bit.0	Initialization by Usage Table

Sense Data Byte 21	Description
Bit.7	RAM Table Validation
Bit.6	Head Test Processing
Bit.5	Loading Read-Only Table
Bit.4	Loading Overlay Code
Bit.3	Loading RAM Code
Bit.2	Starting Spindle Motor
Bit.1	Initiate Microcode Loading
Bit.0	Testing Sector Buffer RAM

Figure 191. Sense Data Byte 20 and 21 for POR Step

Sense Data Byte 22	Description
Bit.7	Not used
Bit.6	12VDC Good
Bit.5	Not used
Bit.4	Not used
Bit.3	Not Used
Bit.2	Not Used
Bit.1	Spindle Motor Spin-Up Failed
Bit.0	EEPROM Data Validation Failed

Figure 192. Sense Data Byte 22 POR Error

Sense Data Byte 23	Description
01h	HDC Test Failure
02h	Sector Buffer RAM Test Failure
03h	EEPROM Read Failure
10h	POR Only Fail
11h	Spin-Up Failure
12h	Reserved Area Table Failure
13h	RAM Code Read Failure
14h	RAM Code Signature Failure
15h	Overlay Code Read Failure
16h	Read-Only Table Read Failure
17h	Head Test Failure
21h	Primary Defect List Read Failure
22h	Grown Defect List Read Failure
23h	Mode Page Parameter Table Read Failure
24h	Persistent Reservation Table Read Failure
25h	SMART Parameter Table Read Failure
26h	Log Parameter Table Read Failure
27h	Usage Table Read Failure
81h	RAM Mapping Failure-Invalid Usage ID
82h	RAM Mapping Failure-Invalid Usage Signature
83h	RAM Mapping Failure-Invalid Table Signature
84h	RAM Mapping Failure-Invalid Table Level

Figure 193. Sense Data Byte 23 for POR Error

12.2.12.2 Read/Write Error (Sense Key 03h/04h)

When an error occurs during a read or write operation, the Vendor Unique Error information will contain the HDC Registers (Status and Error).

Sense Data Byte 20	Description (Status)
Bit.7	Sector Count Over
Bit.6	ECC Error on LBA
Bit.5	Drive Error Detected
Bit.4	Uncorrectable Error
Bit.3	Over Symbol
Bit.2	Correctable Error Preparation
Bit.1	Error On
Bit.0	Drive On

Sense Data Byte 21	Description (Status)
Bit.7	Memory on
Bit.6	Drive Complete
Bit.5	ID Find
Bit.4	ID Miss
Bit.3	Drive Busy
Bit.2	End of Track
Bit.1	Expected Sector Flag
Bit.0	Event Handler Busy

Figure 194. Sense Data Byte 20 and 21 for Read/Write Error

Sense Data Byte 22	Description (Status)
Bit.7	N/A
Bit.6	N/A
Bit.5	N/A
Bit.4	N/A
Bit.3	N/A
Bit.2	Sector Pulse Missing
Bit.1	N/A
Bit.0	Write Fault caused by Servo

Sense Data Byte 23	Description (Status)
Bit.7	Overrun
Bit.6	Write Abort
Bit.5	Write Fault
Bit.4	DAM Mismatch
Bit.3	N/A
Bit.2	REQ Error
Bit.1	11 bytes length of Thermal Asperity
Bit.0	1 byte length of Thermal Asperity (Read) Channel Fault Detect (Write)

Figure 195. Sense Data Byte 22 and 23 for Read/Write Error

12.2.12.3 SMART Alert (Sense Code 5Dh)

When SMART Alert occurs (Sense Code 5Dh), the Vendor Unique Error information byte 21 will contain the following reason code.

Sense Data Byte 21	SMART Alert Reason
32h	Read Error Rate exceeding the threshold
4Ah	Write Error Rate exceeding the threshold
43h	Seek Error Rate exceeding the threshold
14h	Spare Sector Availability Warning
56h	Spin Up Time Warning
5Bh	Spin Up Retry Count Warning
00h	Power On Hour Warning
50h	Load/Unload Cycles Count Warning

Figure 196. Sense Data Byte 21 for SMART Alert Reason Code

12.2.13 Physical Error Record (Byte 24 thru 29)

- ILI = 1 - This field contains zeros.
- ILI = 0 - These bytes contain the physical location of the error in cylinder, head, and sector. Byte 24 and 25 are Cylinder high and cylinder low respectively. Byte 26 is the head number. Byte 28 and 29 are sector high and low respectively.

Byte 27 is retained for compatibility and will contain the sector number for sector 0 to 254 and will be set to 0FFh for sector numbers greater than 254 or if the sector number is undetermined.

If the head undetermined, its value is to 0FFh. If the cylinder value is undetermined, byte 24 and 25 are set to 0FFFFh. If the sector number is undetermined, bytes 27, 28, and 29 are all set to 0FFh. If cylinder, head, and sector have no relevance to the error, bytes 24 through 29 will all be set to 0FFh. This field is valid with Sense Key 1, 3 and 4 only.

12.2.14 Reserved (Byte 30 through 31)

Reserved fields are filled with zero.

A

Acoustics, 52
Actuator, 13
Altitude, 38
Automatic Rewrite/Reallocate, 225
Auxiliary connector, 68-pin model, 32
Average latency, 20
Average seek time, 19

B

Back to Back Write, 224
Breather hole, 48
Buffering operation, 21

C

CE Mark, 54
Command overhead, 18
Command Processing During Execution of Active I/O process, 211
Command Processing During Startup and Format Operations, 214
Command processing while reserved, 221
Command queuing, 222
Command reordering, 224
Concurrent I/O Process, 224
Contingent Allegiance Condition, 228
Control electronics, 13
Cooling requirements, 39
Corrosion test, 38, 40, 41
CSA standard conformity, 55
C-Tick Mark, 54
Cylinder allocation, 17
Cylinder switch time, 20

D

Data integrity, 23
Data reliability, 42
Data transfer speed, 21
Deferred Error, 215
Degraded Mode, 215
Diagnostics, 230
Drive ready time, 20

E

ECC on the fly correction, 42
Electrical interface specification, 27
Electromagnetic compatibility, 54
Equipment errors, 42

Equipment Status, 23
Error recovery procedure, 23

F

Failure prediction (PFA / S.M.A.R.T.), 42
Flammability, 55
Formatted capacity, 15
Full stroke seek time, 19

G

German Safety Mark, 55
G-List, 25

H

Head disk assembly, 13
Head switch time, 20
Hot plug/unplug, 31

I

Idle Time Function, 231
IEC Compliance, 55
Incorrect Initiator Connection, 210
Instantaneous buffer-host transfer rate, 21
Instantaneous disk-buffer transfer rate, 21
Interface connector, 46
Internal Error Condition, 214
Invalid LUN in Identify Message, 210

J

Jumper signal description on J-4, 36
Jumper signal description on J-6, 34

L

Labels, 53

M

Maximum Temperature Gradient, 38
Maximum Wet Bulb Temperature, 38
Mechanical positioning, 19
Mechanical specifications, 44
Mounting, 47
Multiple Initiator Environment, 228

N

Non-arbitrating systems, 227
Non-operating conditions, 38

O

Operating conditions, 38
Option jumper block, 33

P

Performance characteristics, 18
Persistent Reservation, 127
P-List, 25
Power connector, 27
Power requirements, 40
Priority commands, 222
Probability of uncorrectable data error rate, 42

R

Random access, 22
Reassigned format, 25
Relative humidity, 38
Reselection Timeout, 227
Reset condition, 229

S

Safety, 55
SCSI bus connector, 28
SCSI bus Electrical characteristics, 31
SCSI bus terminator, 31
SCSI cable, 31
SCSI Commands, 57
SCSI Control Byte, 58
SCSI Message System, 191
SCSI Protocol, 209
SCSI SENSE DATA, 233
SCSI signal connector - 68-pin, 28
SCSI Signal Connector - 80-pin, 29
SCSI Status Byte, 189
SCSI Status Byte Reporting, 209
Seek/ID miscompare errors, 42
Segmented Caching, 227
Selection without ATN, 228
Sense Data Description, 234
Sense Data Format, 233
Shipped format, 25
Shock, 49
Simple sequential access, 22
Single Initiator Selection, 227
Sound power levels, 52
Spindle stop time, 20
Start /stop cycles, 42
Supported Messages, 191
Sustained disk-buffer transfer rate, 21

T

Temperature, 38
Temperature warning, 43
Terminator power, 31
Throughput, 22

U

UL standard conformity, 55
Unit Attention Condition, 213

V

Vibration, 49

W

Worldwide ID, 73
Write Cache, 225